

Modeling Tools

Objectives

When you complete this module, you will be able to recognize the more advanced modeling tools in Solid Edge as well as the tools that require more input than typical Solid Edge feature commands. The suite of commands covered in this module employs multiple sketches, previously defined construction surfaces, and other user-defined information. These tools require close tracking and inputting more instructions than the commonly used Solid Edge modeling commands. Although the software math routines are complex, the interface is easy to interpret. The major goal of this module is to expose you to the unique SmartStep process and the system requirements you must satisfy to effectively use these commands in their appropriate workflows.

Sweeps and Lofts

The Sweep and Loft commands are designed to handle multiple 3-D curves for both cross-sections and paths. The degree of organization, forethought, and planning required to use these commands effectively is higher than for any other Solid Edge feature creation tool. However, these commands offer great flexibility and many design options. Often, the decision to use a loft feature or a sweep feature is based solely on the amount of control you want to exercise over the transition of a feature from one cross-section to another.

Loft Feature



The Lofted Protrusion command is located on the fly-out menu that also contains Revolved Protrusion, Swept Protrusion, and Helical Protrusion. A Loft feature adds or removes material by constructing blends between cross-sections. The cross-section can be a profile or the edges of the solid.

The following example is a lofted protrusion that uses profiles as cross-sections.

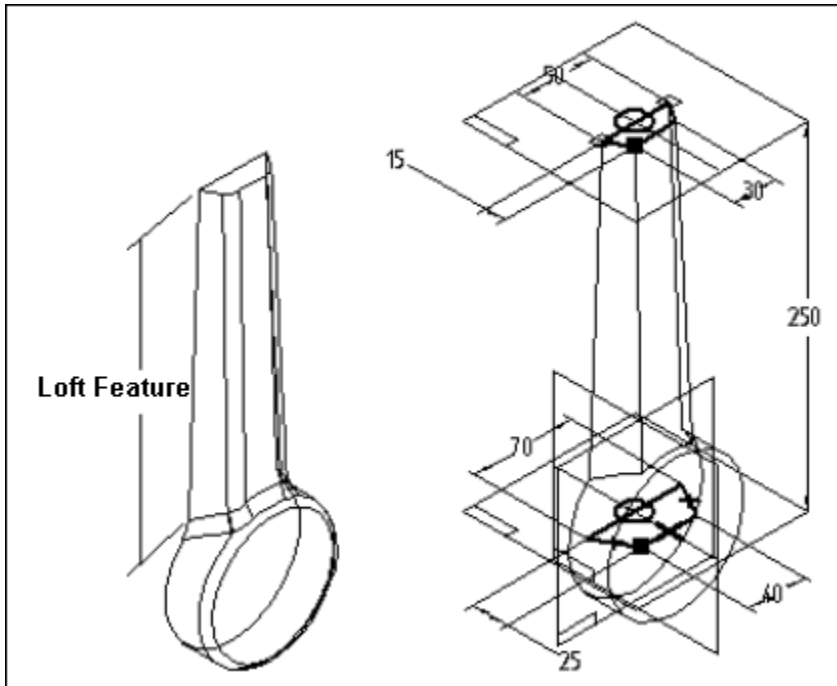

The following example is a lofted protrusion that uses the edges of a solid for its cross-sections.

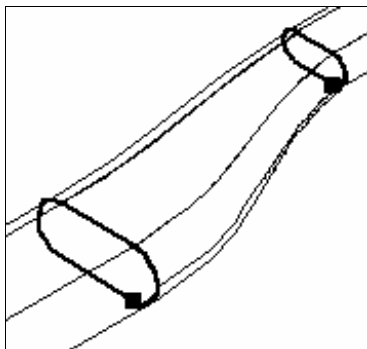
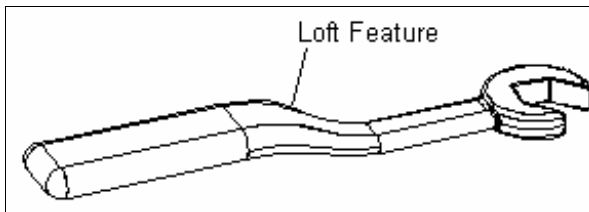

Cross-Section Step

Cross-sections can be defined by two methods: (1) Drawing the geometry as a profile or (2) selecting existing geometry included in sketches and part edges.



When you identify cross-sections, you must also define their start points. Start points should line up between all cross-sections.

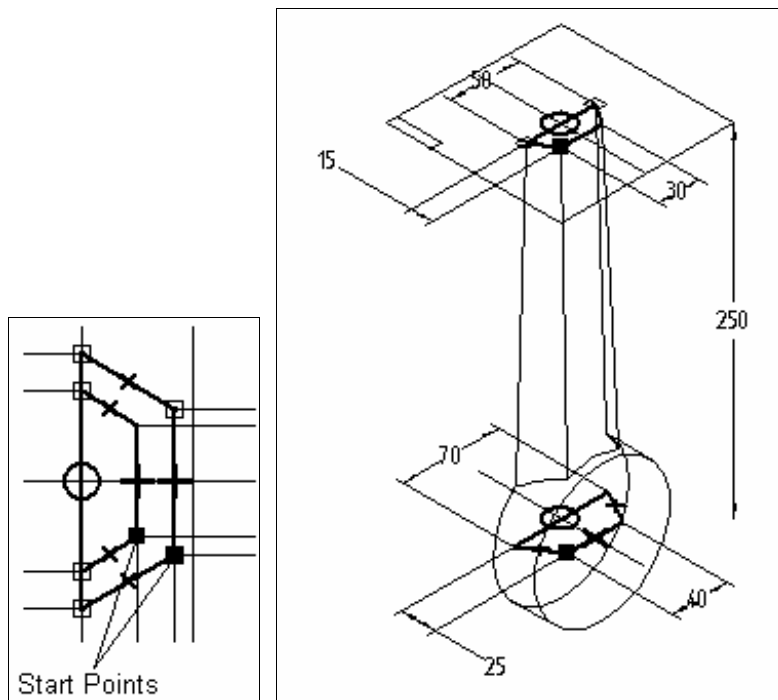

In the following example, the start points for the cross-sections do not line up. Notice that the resulting loft is twisted.

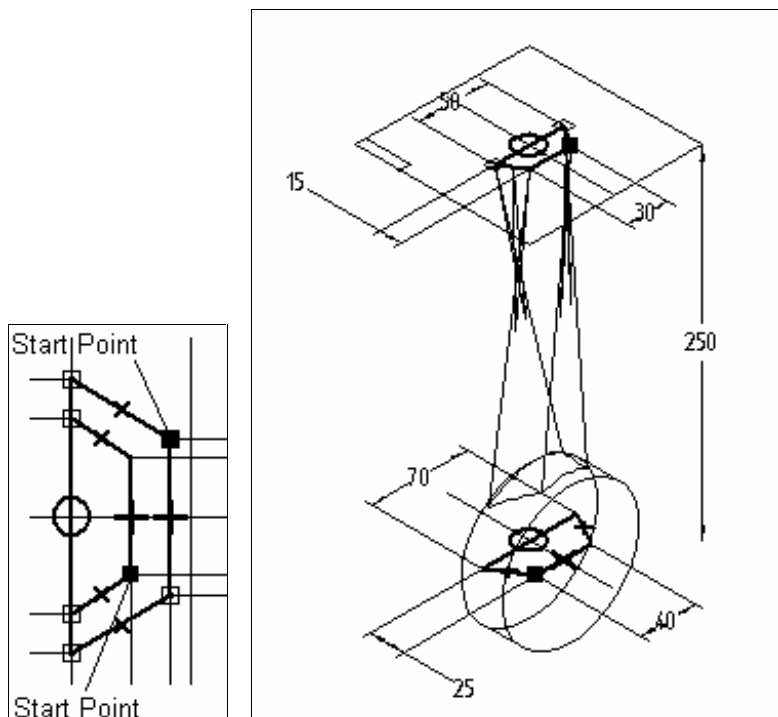

After identifying all cross-sections, use either the guide curve or the extent step. The Guide Curve step lets you select a curve to help control the flow between the cross-sections. Guide curves are

similar to paths used in swept protrusions and cutouts, and they influence the result of the lofted feature.

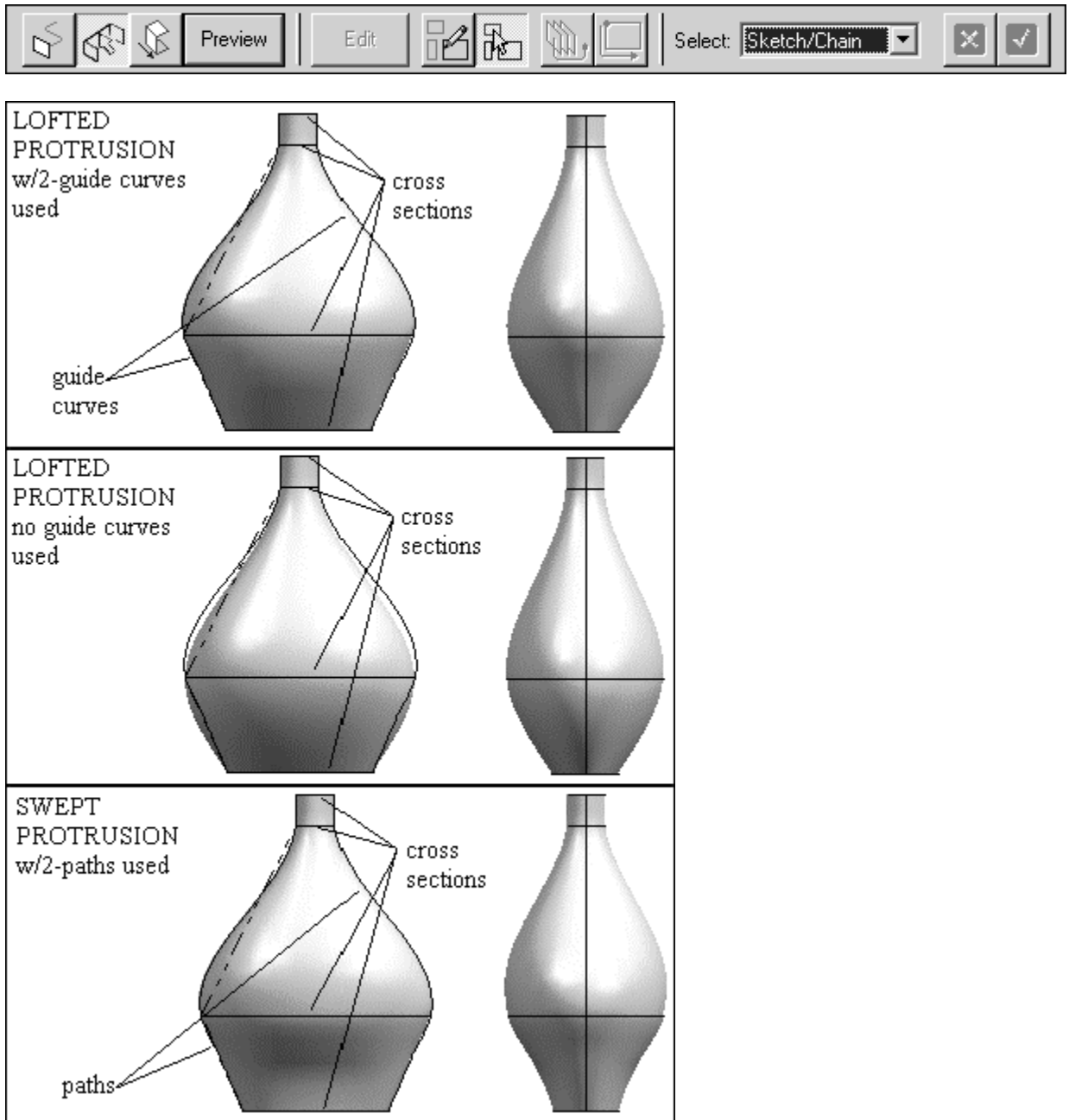

If a guide curve is not required, select the Next option, or use an extent option on the ribbon bar and skip the guide curve step. Using the extent step, you can further control the resulting lofted solid by the following inputs:

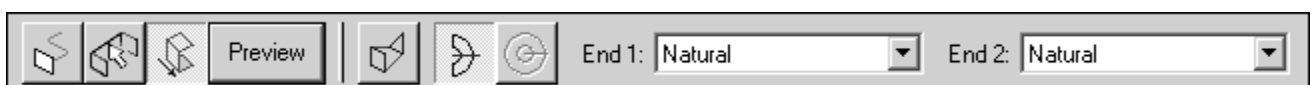

Vertex Mapping

In vertex mapping, points on the cross-sections are mapped to control the loft. Points are defined in sets. The start points define the first set.

Finite Extent

The Finite Extent option fixes the feature extent so that the lofted feature begins with the first cross-section and ends with the last.

Closed Extent

The Closed Extent option fixes the feature extent so that the lofted feature closes on itself, using the first cross-section as both the beginning and the end of the extrusion.

Endpoint Conditions – End 1 and End 2

Endpoint conditions define the end condition for Endpoint 1 and Endpoint 2. End condition options are available for each end of an open loft. If the loft is closed, the end condition options are available for the first cross-section.

- Natural – No constraining condition is enforced at the end. This is the default end condition and is valid for any cross-section type.
- Tangent Continuous – The tangent vector for the loft is determined by the adjacent surfaces. End cross-sections that are defined using part edges and construction surfaces support a tangent condition.
- Curvature Continuous – The curvature take-off vector for the loft is determined by the adjacent surfaces. End cross-sections that are defined using part edges and construction surfaces support a curvature continuous condition.
- Normal to Section – The length of the vector can be controlled. End cross-sections that are planar support a normal to section end condition.

Editing Loft and Swept Features

Loft and Swept features can be edited to add or remove cross-sections. However, if cross-sections are added, the order of the cross-sections should be adjusted. The workflow is as follows:

- Click the loft feature.
- Click the Edit button.
- Click the Cross-Section step and draw the new cross-section, or select an existing cross-section to modify.

- Before clicking Finish and Preview, click the Cross-section Order option.

When a new cross-section is added, it is the last one on the list regardless of its physical location on the model. To place the cross-section in the correct order, select this cross-section and click the Up option. In this example, the cross-section should be moved up between cross-sections 1 and 2. Cross-section selections should be made in sequential order on the model.

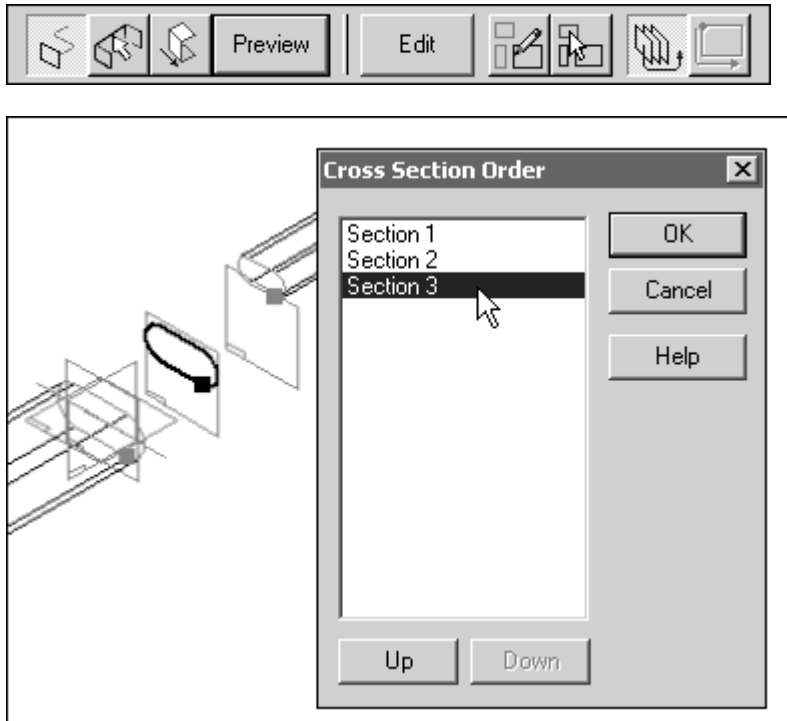

The number assigned to the cross-section follows the order in which the cross-sections are created. Do not confuse this with the order in which the cross-sections are processed.

Swept Feature



A Swept feature is created by transitioning a set of closed cross-sections along a set of paths to either remove or add material. Multiple paths and cross-sections can be specified to control the shape of the feature. The Swept command is located on the fly-out menu that also contains Revolved Protrusion, Lofted Protrusion, Helical Protrusion and Normal Protrusion.



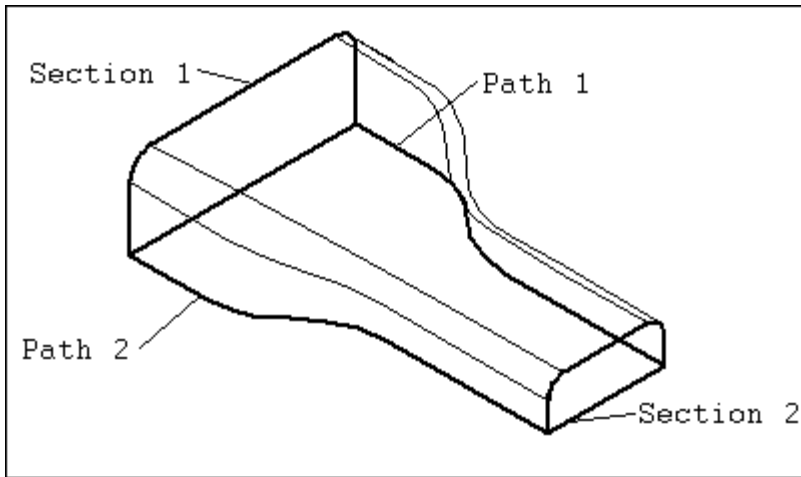

Path Step

The path can be drawn as a profile within the Swept command, selected from a previously drawn sketch, or selected from the edges of a solid. Because a swept feature can contain up to three (3) paths and multiple cross-sections, draw the geometry as 2-D sketches. Under the Sweep Options dialog box, you can select either 'single path and cross-section' or 'multiple paths and cross-sections'.

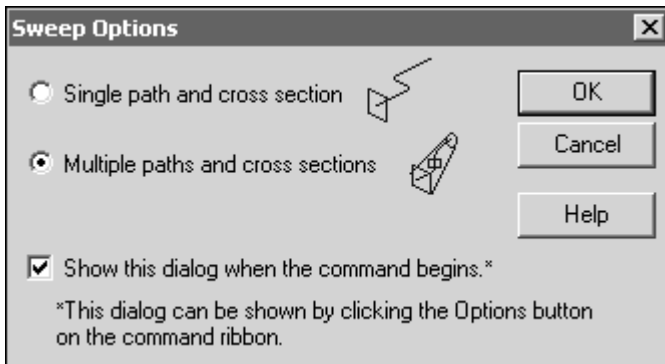

- Draw Path



The path is drawn as a profile. The profile path must be a continuous set of tangent edges. The Swept command does not allow a path with sharp corners.

-

- Select



Use this option to select paths and cross-sections from existing geometry. A pull-down menu offers choices of geometry types for selecting the paths and cross-sections. If you use fewer than three paths, click Next on the ribbon bar to transition from the path step to the cross-section step.

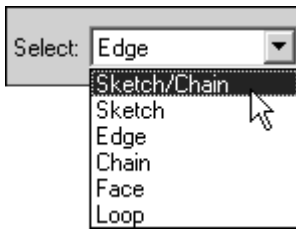

Cross-Section Step

Cross-section profiles must be closed. They do not have to be a set of continuous tangent edges like the paths: sharp corners on cross-sections are allowed. You can define cross-section profiles in the following ways: create them as sketches, pick edges of the solid, and draw the profile within the cross-section step. The path and cross-sections should be drawn as sketches.

If you use the Draw option to create the cross-sections within the Swept Protrusion command, Solid Edge needs to know where to draw the section. For example, after two paths are created, the first cross-section can be drawn relative to the left or right ends of the paths. A point displays at one end of the path, depending on where you position the cursor. If you move the mouse to the other end of the path, the point moves there as well.

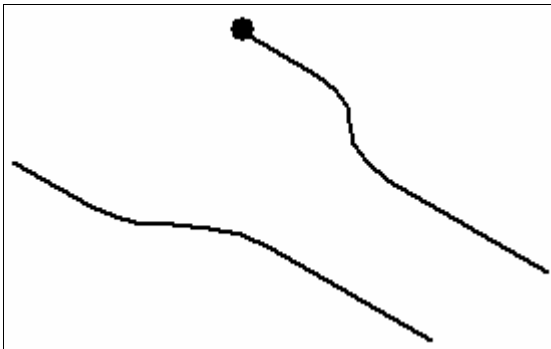

After you accept the point with a click, a small reference plane is constructed at the end of the path. Positioning the cursor to select the origin of the plane orients the reference plane.

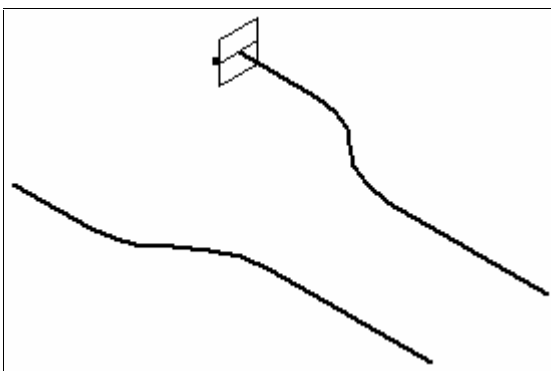

After finishing the cross-section, define the cross-section start point. Do this by positioning the mouse cursor over the profile and selecting a vertex.

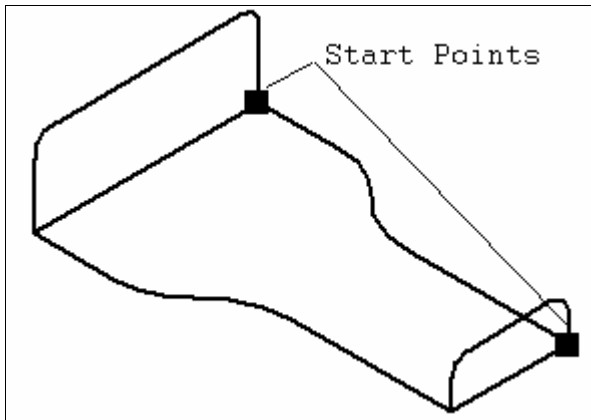

With only one cross-section, the start point is not critical. But where multiple sections exist, take care that the starting points of each cross-section are aligned as shown in the previous illustration. Otherwise, the part will twist as shown in the following illustration. When selecting cross-sections from sketches, start points are defined at the time you select them.

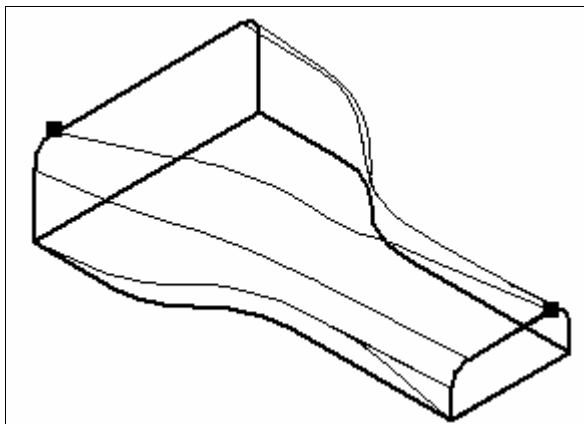

Activity 1 – Constructing a Swept Protrusion

Overview

When you complete this activity, you will understand the options and requirements for constructing a swept feature.

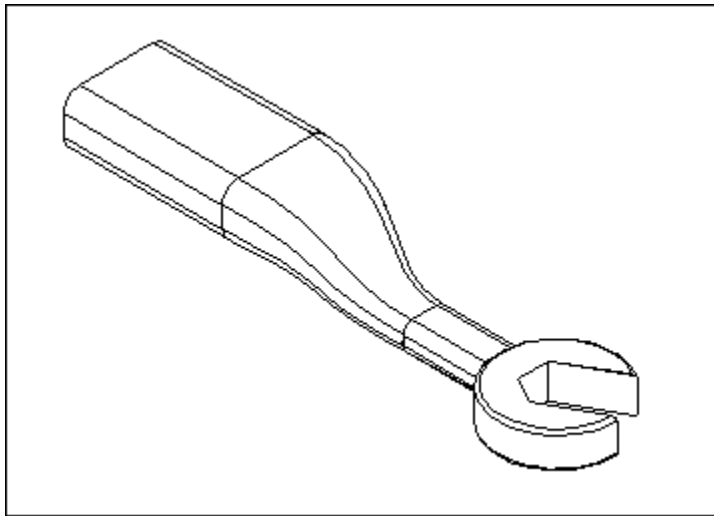

1. Draw the part.

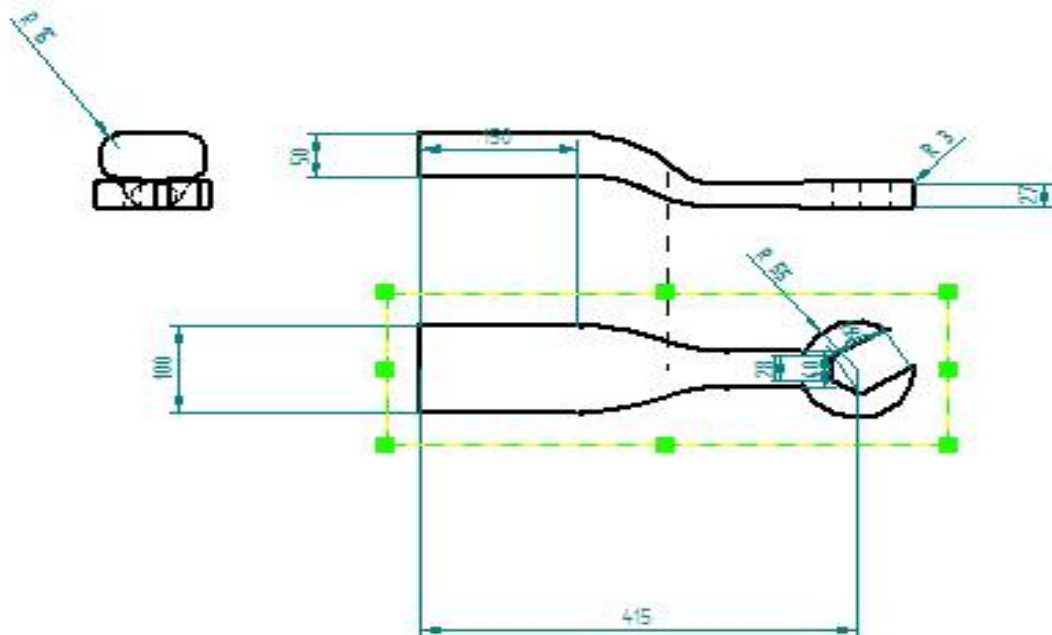

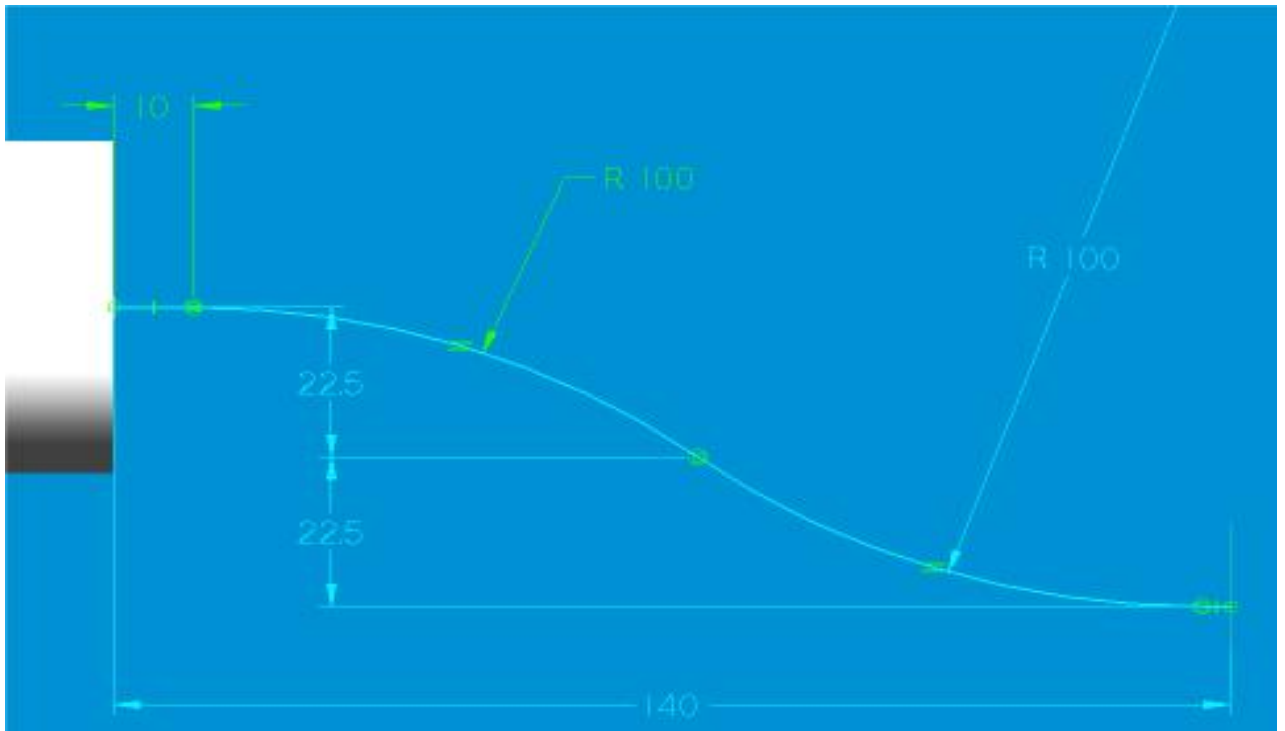

2. You will now create a swept protrusion feature.

- On the Features toolbar, click the Swept Protrusion command.

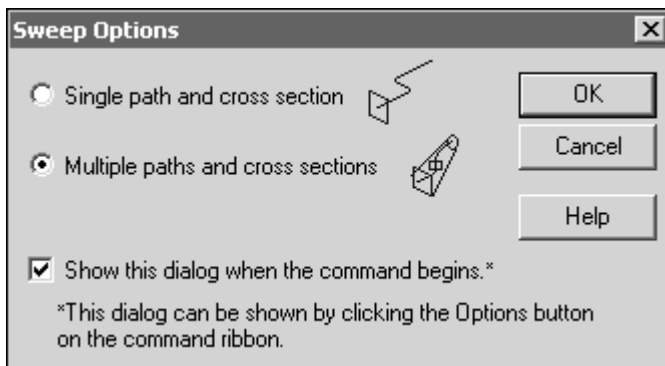

- Set the Multiple Paths and Cross-Sections option.
-
- Select the path sketch and then click the accept button.

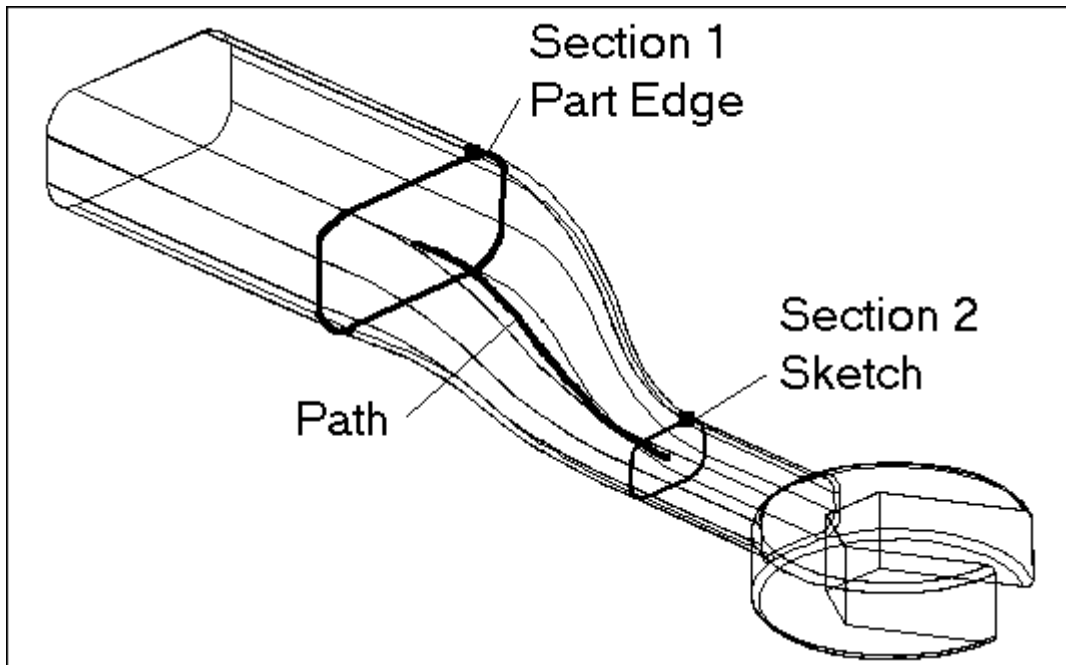

- ❑ On the ribbon bar, click Next.
 - ❑ Select the model edge cross-section, and then select the sketch cross-section. Notice that the software displays key points when you position the mouse over the cross-sections. Use these key points as start points. Position the start points of the two cross-sections on the same vertex on each profile.
 - ❑ On the ribbon bar, click Preview and then Finish.
3. Save and close the file. This completes the activity.

Activity 2 – Constructing a Lofted Protrusion

Overview

When you complete this activity, you will understand the options and requirements for constructing a lofted protrusion. You will construct the feature with two cross-sections. When the feature is complete, you will edit it to include a third cross-section.

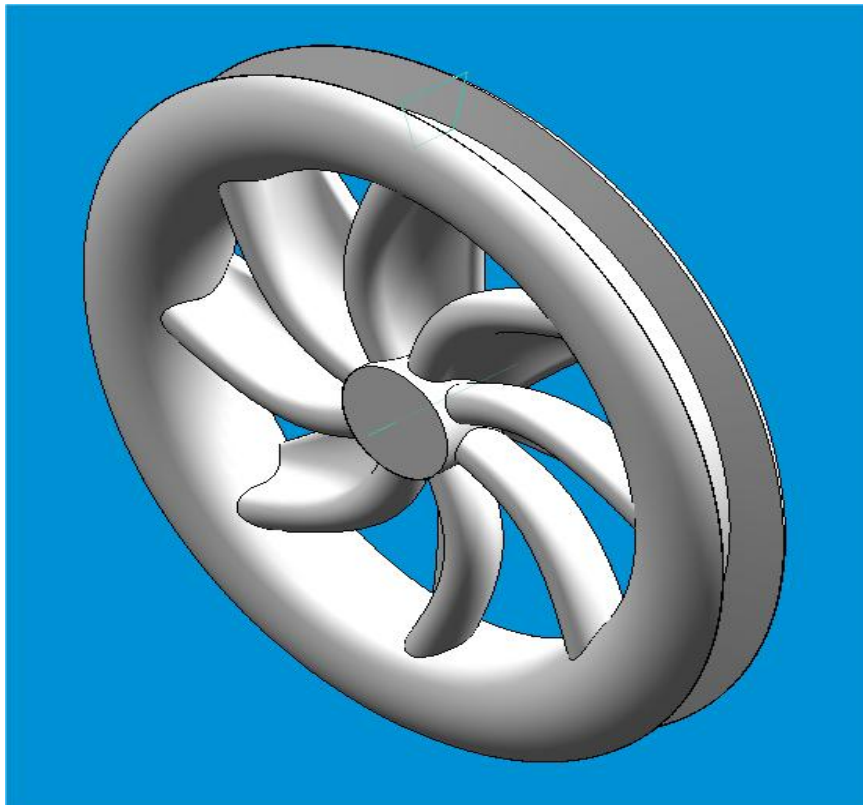
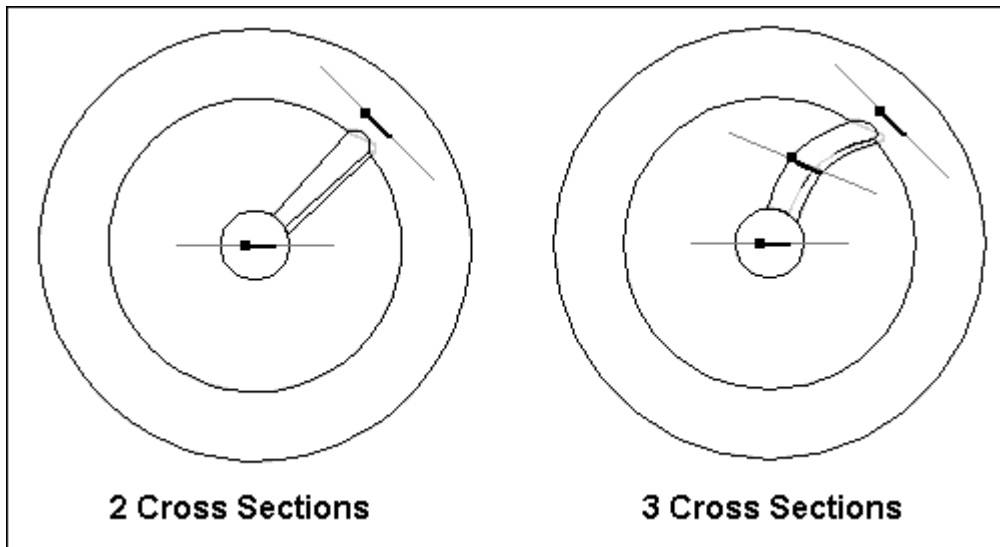

1. Draw the part..

2. Construct a lofted protrusion between the three sketches. Notice how the loft is a straight transition from one curve to the next.

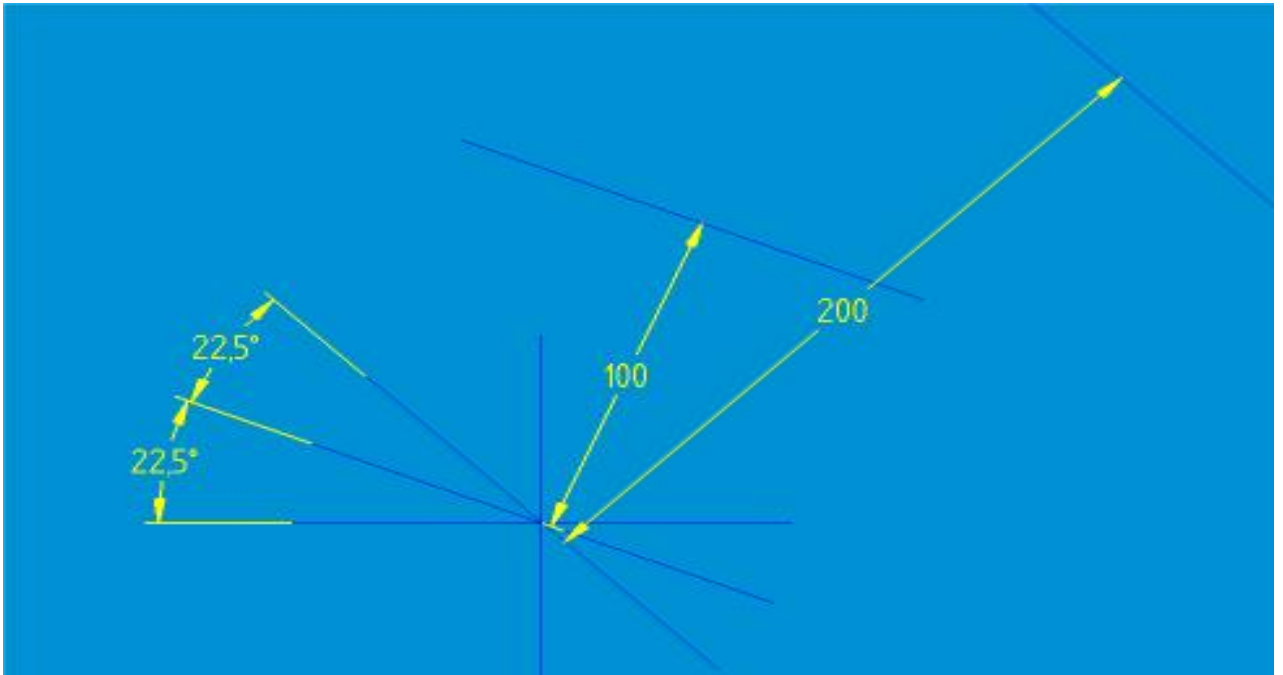

1-st sketch

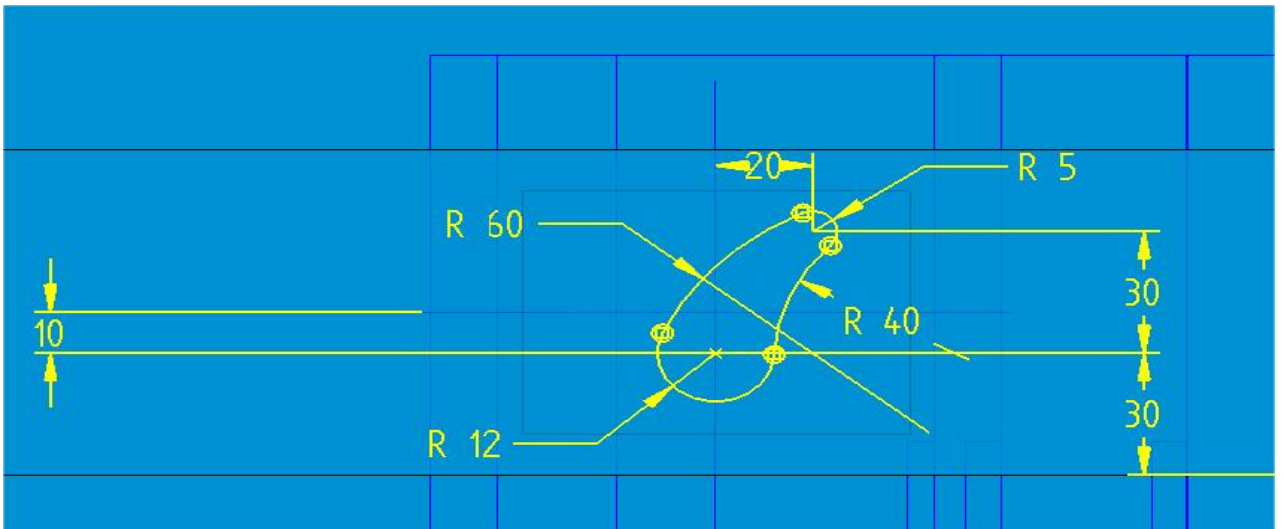

2-nd sketch

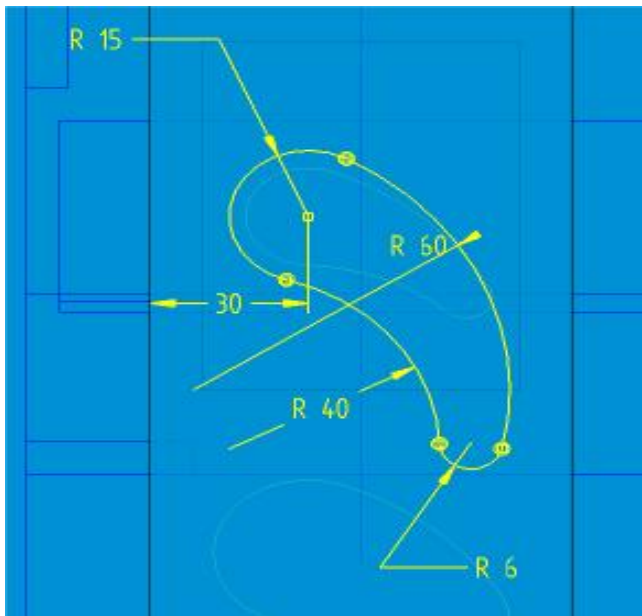

3-nd sketch

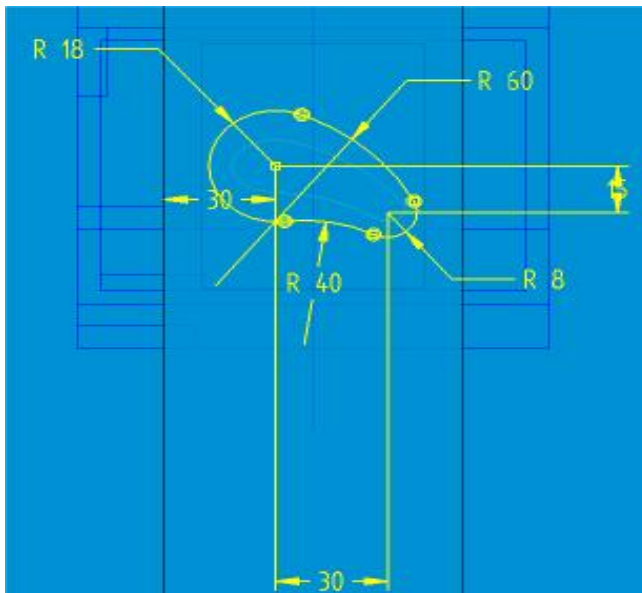

Cutout

