

# Panasonic®

## Operating Instructions

Memory Card Camera-Recorder

Model No. **AJ-PX270EJ**

**P2HD**  
*micro*  
**P2**

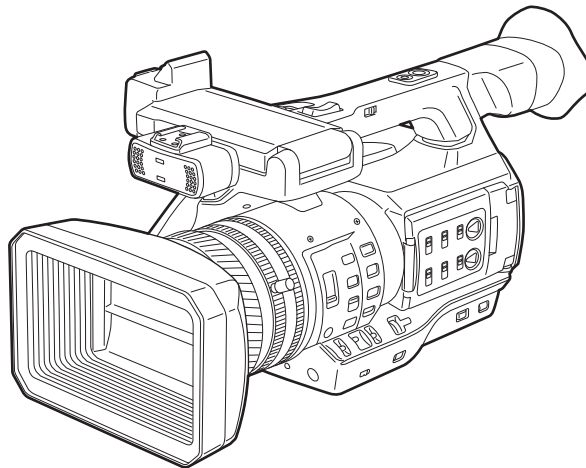

**HDMI**



**AVCULTRA**

**AVCINTRA**

**AVCLONGG**

**DVCPROHD**

**DVCPRO50**

**DVCPRO**

**DN**

Before operating this product, please read the instructions carefully and save this manual for future use.

# Read this first!



indicates safety information.

## **WARNING:**

- To reduce the risk of fire or electric shock, do not expose this equipment to rain or moisture.
- To reduce the risk of fire or electric shock, keep this equipment away from all liquids. Use and store only in locations which are not exposed to the risk of dripping or splashing liquids, and do not place any liquid containers on top of the equipment.

## **WARNING:**

Always keep memory cards (optional accessory) or accessories (microphone holder screws) out of the reach of babies and small children.

## **CAUTION:**

Do not remove panel covers by unscrewing them. To reduce the risk of electric shock, do not remove cover. No user serviceable parts inside. Refer servicing to qualified service personnel.

## **CAUTION:**

The mains plug of the power supply cord shall remain readily operable.  
The AC receptacle (mains socket outlet) shall be installed near the equipment and shall be easily accessible.  
To completely disconnect this equipment from the AC mains, disconnect the power cord plug from the AC receptacle.

## **CAUTION:**

Danger of explosion or fire if battery is incorrectly replaced or mistreated.  
Do not disassemble the battery or dispose of it in fire.  
Do not store in temperatures over 60°C.  
Do not expose the battery to excessive heat such as sunshine, fire or the like.

### **For Battery Pack**

Use specified charger.  
Replace only with same or specified type.

## **CAUTION:**

To reduce the risk of fire or electric shock and annoying interference, use the recommended accessories only.

## **CAUTION:**

Do not jar, swing, or shake the unit by its handle while the conversion lens or another accessory is attached.  
Due to the added weight of the conversion lens, any strong jolt to the handle may damage the unit or result in personal injury.

## **CAUTION:**

In order to maintain adequate ventilation, do not install or place this unit in a bookcase, built-in cabinet or any other confined space. To prevent risk of electric shock or fire hazard due to overheating, ensure that curtains and any other materials do not obstruct the ventilation.

## **CAUTION:**

Do not lift the unit by its handle while the tripod is attached. When the tripod is attached, its weight will also affect the unit's handle, possibly causing the handle to break and hurting the user. To carry the unit while the tripod is attached, take hold of the tripod.

## **CAUTION:**

Excessive sound pressure from earphones and headphones can cause hearing loss.

## **CAUTION:**

Do not leave the unit in direct contact with the skin for long periods of time when in use.  
Low temperature burn injuries may be suffered if the high temperature parts of this unit are in direct contact with the skin for long periods of time.  
When using the equipment for long periods of time, make use of the tripod.

## **CAUTION:**

Keep metal objects (such as necklaces and hairpins) away from the battery.  
Short-circuiting may occur across the terminals, causing the battery to heat up, and you may seriously burn yourself if you touch the battery in this state.

## **CAUTION:**

A coin type battery is installed inside of the unit.  
Do not store the unit in temperatures over 60 °C.  
Do not leave the unit in an automobile exposed to direct sunlight for a long period of time with doors and windows closed.

## Caution for AC Mains Lead

**FOR YOUR SAFETY PLEASE READ THE FOLLOWING TEXT CAREFULLY.**

This product is equipped with 2 types of AC mains cable. One is for continental Europe, etc. and the other one is only for U.K.

Appropriate mains cable must be used in each local area, since the other type of mains cable is not suitable.

### TYPE C

(FOR CONTINENTAL EUROPE, ETC.  
Not to be used in the U.K.)

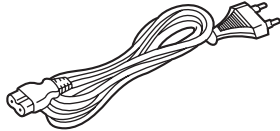

### TYPE BF

(FOR U.K. ONLY)

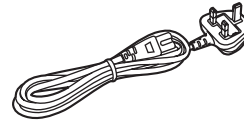

### FOR U.K. ONLY

This appliance is supplied with a moulded three pin mains plug for your safety and convenience.

A 5 amp fuse is fitted in this plug.

Should the fuse need to be replaced please ensure that the replacement fuse has a rating of 5 amps and that it is approved by ASTA or BSI to BS1362.

Check for the ASTA mark  or the BSI mark  on the body of the fuse.

If the plug contains a removable fuse cover you must ensure that it is refitted when the fuse is replaced.

If you lose the fuse cover the plug must not be used until a replacement cover is obtained.

A replacement fuse cover can be purchased from your local Panasonic Dealer.

### How to replace the fuse

1. Open the fuse compartment with a screwdriver.

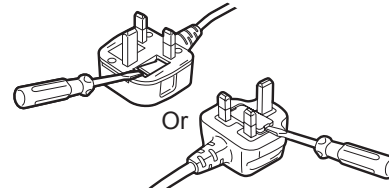

2. Replace the fuse.

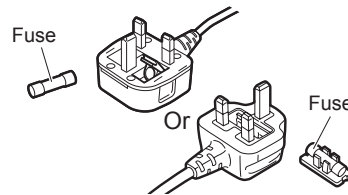

### For Turkey

EEE Yönetmeliğine Uygundur.

EEE Complies with Directive of Turkey.

The rating plate is on the underside of the Camera Recorder, Battery Charger and AC Adaptor.

This equipment is in compliance with the essential requirements and other relevant provisions of Directive 1999/5/EC.

Customers can download a copy of the original DoC for this product from our DoC server:  
<http://www.ptc.panasonic.de/>

Manufactured by: Panasonic Corporation, Osaka, Japan

Importer's name and address of pursuant to EU rules:

**Panasonic Marketing Europe GmbH**

**Panasonic Testing Centre**

Winsbergring 15, 22525 Hamburg, Germany



■ **Batteries that may be used with this product (Correct as of January 2015)**

Panasonic VW-VBD58 batteries may be used with this product.

Note regarding the Power Management function specified under COMMISSION REGULATION (EC) No 1275/2008 implementing Directive 2009/125/EC of the European Parliament and of the Council.

This device is designed and manufactured for use at a broadcasting station and/or in a similar environment. This device is not equipped with a Power Management function or the Power Management function is set to OFF as it will prevent the device from fulfilling its intended purpose for the reasons below.

1. If the device is a Studio Camera, a Weather Camera, a Mixer or other processor:  
A Power Management function may cause the device to suddenly stop during recording or while On Air.
2. If the device is a Studio Monitor:  
A Power Management function may cause video for the confirmation of whether a signal is normal, or whether the signal has been lost, to be un-viewable.
3. If the device is a Camera Recorder:  
A professional camera recorder must be able to start quickly at any time, but a Power Management function will cause an increase in the time taken to resume from Stand-by mode.

It has been found that counterfeit battery packs which look very similar to the genuine product are made available to purchase in some markets. Some of these battery packs are not adequately protected with internal protection to meet the requirements of appropriate safety standards. There is a possibility that these battery packs may lead to fire or explosion. Please be advised that we are not liable for any accident or failure occurring as a result of use of a counterfeit battery pack. To ensure that safe products are used we would recommend that a genuine Panasonic battery pack is used.

## To remove the battery

### Main Power Battery (Lithium ion Battery) (Refer to page 26 for the detail.)

Press the battery release button.

Battery release button

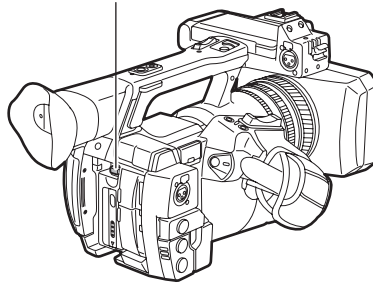

### Back-up Battery (Lithium Battery)

- For the removal of the battery for disposal at the end of its service life, please consult your dealer.

### Battery Charger / AC Adaptor

Disconnect the AC mains plug from the AC mains socket when not in use.

- 
- SDXC logo is a trademark of SD-3C, LLC.
  - HDMI, HDMI logo, and High-Definition Multimedia Interface are trademarks or registered trademarks of HDMI Licensing LLC in the United States and/or other countries.
  - MMC (Multi Media Card) is a registered trademark of Infineon Technologies AG.
  - Microsoft® and Windows® are registered trademarks or trademarks of Microsoft Corporation in the United States and/or other countries.
  - Screenshots are used according to Microsoft Corporation guidelines.
  - Apple, Macintosh, Mac OS, QuickTime, iPad, and iPhone are trademarks or registered trademarks of Apple Inc. in the United States and/or other countries.
  - Java and all Java-based trademarks are trademarks or registered trademarks of Sun Microsystems, Inc. in the United States.
  - All other names, company names, product names, etc., contained in this instruction manual are trademarks or registered trademarks of their respective owners.
  - This product is licensed under the AVC Patent Portfolio License. All other acts are not licensed except private use for personal and non-profit purposes such as what are described below.
    - To record video in compliance with the AVC standard (AVC Video)
    - To play back AVC Video that was recorded by a consumer engaged in a personal and non-commercial activity
    - To play back AVC Video that was obtained from a video provider licensed to provide the videoVisit the MPEG LA, LLC website (<http://www.mpegla.com/>) for details.
  - Use of DCF Technologies under license from Multi-Format, Inc.

---

## How to read this document

---

### ■ Illustrations

- Illustrations of the camera, menu screens, and other items, may vary from the actual items.

### ■ Conventions used in this manual

- Words and phrases in [ ] brackets indicate details and content displayed in the viewfinder or LCD monitor.
- Words and phrases in < > brackets indicate design text used on this camera, such as button names.

### ■ Reference pages

- Reference pages in this document are indicated by (page 00).

### ■ Terminology

- SD memory card, SDHC memory card, and SDXC memory card are referred to as "SD memory card".
- A memory card with the "P2" logo such as AJ-P2E064FG memory card (optional) is referred to as a "P2 memory card".
- A memory card with the "microP2" logo such as AJ-P2M032AG memory card (optional) is referred to as a "microP2 memory card".
- P2 memory card and microP2 memory card are referred to only as "P2 card" unless distinguished otherwise.
- Media such as external hard disk drives (HDD) connected to USB are referred to as "storage devices".
- Video that is created during a single recording operation is referred to as a "clip".

# Contents

<b>Read this first!</b> .....	<b>2</b>	<b>Adjusting image quality</b> .....	<b>54</b>
<b>Chapter 1 Overview</b> .....	<b>9</b>	Detail function .....	54
<b>Before using the camera</b> .....	<b>10</b>	Skin tone function .....	54
<b>Use of the camera on a system</b> .....	<b>12</b>	RB gain control function .....	55
Basic configuration devices .....	12	Chroma setting function .....	55
Expanded configuration devices .....	12	Matrix function .....	55
<b>What you can do with this camera</b> .....	<b>13</b>	Color correction function .....	56
Recording to the memory card .....	13	Black control function .....	56
Linking to external devices .....	13	Gamma function .....	56
Connecting to the network .....	14	Knee function .....	56
<b>Chapter 2 Description of Parts</b> .....	<b>15</b>	High color function .....	57
<b>Left side</b> .....	<b>16</b>	White clip function .....	57
<b>Right side</b> .....	<b>18</b>	<b>Setting the electronic shutter</b> .....	<b>58</b>
<b>Front side, rear side</b> .....	<b>20</b>	Shutter mode .....	58
<b>Top side</b> .....	<b>22</b>	Adjusting with the <SEL/PUSH SET> dial button and <MODE/ MENU CANCEL> button .....	58
<b>Chapter 3 Preparation</b> .....	<b>24</b>	<b>Flash band compensation (FBC) function</b> .....	<b>59</b>
<b>Power supply</b> .....	<b>25</b>	Setting the flash band compensation function .....	59
Charging the battery .....	25	<b>Variable frame rate (VFR) recording function</b> .....	<b>60</b>
Attaching and removing the battery .....	26	Native variable frame rate recording .....	60
Using the AC adaptor .....	26	Standard variable frame rate recording (pull-down recording) .....	60
<b>Attaching and adjusting accessories</b> .....	<b>28</b>	<b>Selecting audio input and adjusting recording levels</b> .....	<b>62</b>
Adjusting the grip strap .....	28	Selecting audio input signals .....	62
Attaching the shoulder strap .....	28	Using the built-in microphone .....	62
Attaching the lens hood .....	28	Using the external microphone and audio device .....	62
Attaching the eye cup .....	29	Adjusting the recording level .....	63
Attaching the front microphone .....	30	Displaying the audio level detailed .....	63
Attaching a tripod .....	30	<b>Getting position information using the GPS</b> .....	<b>64</b>
<b>Turning on/off the power</b> .....	<b>31</b>	<b>Special recording functions</b> .....	<b>65</b>
How to turn on the power .....	31	Pre-recording .....	65
How to turn off the power .....	31	Interval recording .....	65
<b>Setting the date/time of the internal clock</b> .....	<b>32</b>	One-shot recording .....	66
<b>P2 card</b> .....	<b>33</b>	Loop recording .....	66
Inserting a P2 card .....	33	One-clip recording .....	67
Removing a P2 card .....	34	Simultaneous recording .....	68
Preventing accidental erasure .....	34	Background recording .....	68
P2 card access LEDs and status of P2 cards .....	34	Hot swap recording .....	69
P2 card recording time .....	35	Recording check function .....	70
CPS (Content Protection System) .....	36	Shot mark recording function .....	70
How to handle data recorded on P2 cards .....	36	Text memo recording function .....	70
<b>Assigning functions to the USER buttons</b> .....	<b>37</b>	<b>Convenient shooting functions</b> .....	<b>71</b>
<b>Adjusting and setting the LCD monitor</b> .....	<b>39</b>	Low angle shooting .....	71
Using the LCD monitor .....	39	Scan reverse shooting .....	71
Adjusting the LCD monitor .....	39	Zebra patterns display .....	71
Mirror shooting .....	39	Displaying the center marker .....	71
Highlighting the outlines of images .....	39	Displaying the safety zone marker .....	71
<b>Adjusting and setting the viewfinder</b> .....	<b>40</b>	Displaying frame marker .....	72
Using the viewfinder .....	40	Checking and displaying the shooting status .....	72
Adjusting the viewfinder .....	40	Changing image size .....	72
Highlighting the outlines of images .....	40	Image stabilization function .....	72
<b>Tally lamp</b> .....	<b>41</b>	Dynamic range stretcher function .....	72
<b>Chapter 4 Shooting</b> .....	<b>42</b>	Backlight compensation .....	72
<b>Basic procedures</b> .....	<b>43</b>	Color bars .....	72
Preparation .....	43	Time stamp function .....	72
Shooting .....	43	Deleting last clip function .....	73
Selecting the resolution, codec, and video format for recording .....	44	Waveform monitor function .....	73
<b>Adjustable settings when shooting</b> .....	<b>46</b>	Direct menu operation .....	73
Iris .....	46	<b>Multi formats</b> .....	<b>74</b>
Gain .....	46	Selecting recording signals .....	74
Super gain .....	46	System modes and recording functions .....	74
Brightness adjustment .....	46	List of recording settings and recording functions .....	79
Macro .....	46	Selecting video output .....	80
Focusing (manual focus) .....	46	Recording/playback and output format list .....	81
Focus assist function .....	47	<b>Dual codec recording</b> .....	<b>83</b>
Area mode function .....	48	Dual codec recording setting .....	83
Level gauge function .....	49	Recording the proxy data .....	83
<b>Adjusting the white and black balance</b> .....	<b>50</b>	Recording to the SD memory card .....	84
Adjusting the white balance .....	50	Checking the proxy data .....	84
Adjusting the black balance .....	51	Error displays about proxy data recordings .....	85
<b>Using the zoom function</b> .....	<b>53</b>	<b>Streaming function</b> .....	<b>87</b>
Setting the <ZOOM> switch .....	53	Setting the network connection .....	87
Adjusting the zoom position .....	53	Setting the streaming function .....	87
Zoom ring .....	53	List of system modes and supported streaming output .....	87
		List of streaming modes and resolution/frame rates .....	87
		<b>Handling setting data</b> .....	<b>89</b>
		Setting data file configuration .....	89
		Handling SD memory cards .....	89
		Performing operations on SD memory cards .....	90
		How to use user data .....	91



How to use scene file data .....	91	<b>Chapter 8 Connecting to External Devices</b>	<b>159</b>
How to restore the scene file or menu setting status to the factory settings .....	93	<b>Connecting with headphones, remote control, or TV/ monitor</b> .....	<b>160</b>
Saving to an SD memory card and loading saved data .....	93	Headphones .....	160
<b>Selection of external reference signal and generator lock setting</b> .....	<b>94</b>	Remote control .....	160
Locking the video signal to the external reference signal .....	94	TV/monitor .....	160
<b>Setting the time data</b> .....	<b>95</b>	<b>Connection function via &lt;USB2.0 DEVICE&gt; or &lt;USB3.0 HOST&gt; terminal</b> .....	<b>162</b>
Recording of time codes and user bits .....	95	Connecting to a computer in the USB device mode .....	162
User bits settings .....	99	Connecting to external devices in USB host mode .....	162
How to input user bits .....	100	<b>Connecting to the remote operation panel (AK-HRP200G)</b> .....	<b>170</b>
Setting the time code .....	101	Switch function in remote control mode .....	170
Externally locking the time code .....	102	Recording and playback operations in remote control mode .....	170
Supplying the time code externally .....	103	Remote control unit connected to the camera .....	170
Connecting and setting the genlock and time code input/ output .....	104	<b>Connecting to P2 ROP application</b> .....	<b>172</b>
Setting and displaying the counter .....	104	Switch functionality in remote control mode .....	172
<b>Chapter 5 Playback</b>	<b>105</b>	Recording and playback operations in remote control mode .....	172
<b>Basic procedures</b> .....	<b>106</b>	<b>Chapter 9 Network Connection</b>	<b>173</b>
Preparation .....	106	<b>Network connection</b> .....	<b>174</b>
Playback .....	106	Available functions .....	174
<b>Thumbnail operations</b> .....	<b>107</b>	Operating environment .....	174
Thumbnail operation overview .....	107	<b>Preparing for connection</b> .....	<b>175</b>
Thumbnail screen .....	107	For wireless LAN .....	175
Selecting thumbnails .....	109	For wired LAN .....	176
Setting thumbnail screen display .....	109	For 4G/LTE .....	176
Changing thumbnails .....	111	<b>Network settings</b> .....	<b>177</b>
Shot mark .....	111	Wireless LAN settings .....	177
Text memo .....	111	Wired LAN settings .....	179
Deleting clips .....	113	<b>Network function</b> .....	<b>181</b>
Restoring clips .....	113	P2 browser function settings and connection status check .....	181
Reconnecting incomplete clips .....	113	Setting the P2 playlist edit function .....	181
Copying clips .....	113	Setting for connection with P2 ROP application .....	182
Setting clip metadata .....	114	Setting for connection with Remote Operation Panel (AK-HRP200G) .....	183
Formatting a P2 card .....	116	<b>Using FTP client function</b> .....	<b>184</b>
Formatting SD memory cards .....	116	FTP client function setting .....	184
Properties .....	117	FTP server folder list (FTP explorer screen) .....	185
<b>Chapter 6 Menu Operations</b>	<b>122</b>	Deleting clips on the FTP server .....	186
<b>Setting menu structure</b> .....	<b>123</b>	Viewing information of clips on FTP server .....	187
Menu types and how to open them .....	123	Transferring from a P2 card to an FTP server (copy) .....	187
Main menu structure .....	123	Transferring from an SD card to an FTP server (export) .....	187
<b>Setting menu display</b> .....	<b>124</b>	<b>Rec during upload function</b> .....	<b>189</b>
Setting menu basic operations .....	124	Transferring recorded clips automatically (automatic transfer mode) .....	189
Setting [USER MENU] .....	125	Transferring selected clips automatically (manual selection mode) .....	189
Setting menu initialization .....	125	Displaying the upload list .....	190
<b>Menu list</b> .....	<b>127</b>	<b>Chapter 10 Maintenance and Inspection</b>	<b>191</b>
[SCENE FILE] .....	127	<b>Maintenance</b> .....	<b>192</b>
[SYSTEM MODE] .....	132	Charging the built-in battery .....	192
[USER SW] .....	133	<b>Frequently asked questions</b> .....	<b>193</b>
[SW MODE] .....	134	Power supply .....	193
[AUTO SW] .....	135	Battery .....	193
[RECORDING SETUP] .....	136	Shooting .....	193
[CLIP] .....	138	Editing .....	193
[AUDIO SETUP] .....	140	Playback .....	193
[OUTPUT SEL] .....	141	Others .....	194
[NETWORK SETUP] .....	142	<b>Warning system</b> .....	<b>195</b>
[DISPLAY SETUP] .....	144	Cases indicated by error codes .....	195
[CARD FUNCTIONS] .....	146	Cases indicated by error messages .....	195
[OTHER FUNCTIONS] .....	147	<b>Updating the camera firmware</b> .....	<b>199</b>
[MAINTENANCE] .....	147	<b>Cleaning and storing</b> .....	<b>200</b>
[DIAGNOSTIC] .....	147	Cleaning the camera recorder .....	200
[USER MENU SEL] .....	148	Cautions when storing the camera recorder .....	200
<b>[OPTION MENU] list</b> .....	<b>149</b>	<b>Chapter 11 Specification</b>	<b>201</b>
[AWB PRE CONTROL] .....	149	<b>Specifications</b> .....	<b>202</b>
[CAM REMOTE ADJ.] .....	149	Dimensions .....	202
[ENG SECURITY] .....	149	Specifications .....	202
<b>Chapter 7 Display</b>	<b>150</b>	<b>Index</b> .....	<b>207</b>
<b>Screen status display</b> .....	<b>151</b>		
Configuration of status display on screen .....	151		
Selecting display items on screen .....	151		
Displaying screen .....	151		
Checking and displaying shooting status .....	155		
Mode check display .....	157		



# Chapter 1 Overview

---

Before using the camera, read this chapter.

**For accessories, refer to the leaflet supplied with the product.**

## Before using the camera

### ■ When using this product during rain or snow or when at the beach, be careful that water does not get inside the camera recorder.

Water causes damage to the camera recorder and memory card. (Repair may be impossible)

### ■ Keep the camera recorder away from devices (TVs, TV games, etc.) that produce magnetism.

- If you use the camera recorder on or near TVs, video and sound data may be distorted by electromagnetic waves.
- Strong magnetic fields produced by speakers and large motors may cause damage to recorded contents and may distort images.
- Electromagnetic waves emitted by microcomputers may have a harmful effect on the camera recorder and may corrupt video and sound data.
- The camera recorder may not operate properly if it receives harmful effects from devices that produce magnetism. If this happens, turn off the camera recorder and either remove the battery or unplug the AC adaptor from the power outlet. Then, replace the battery or reconnect the AC adaptor. After that, turn on the camera recorder.

### ■ Do not use the camera recorder near radio transmitters or high-voltage devices.

If you use the camera recorder near radio transmitters or high-voltage devices, the recorded video and sound data may suffer harmful effects.

### ■ When using the camera recorder at the beach, etc., be careful that sand and dust do not get inside the camera recorder.

Sand and dust may damage the camera recorder and memory card. (Be careful when inserting and removing the memory card)

### ■ Battery charger and battery

- If the <CHARGE> lamp continues blinking even when the battery is at its optimal temperature, the battery or battery charger may be damaged. Contact a dealer.
- If the battery is warm, it will take longer than usual to charge.
- If you use the battery charger near a radio, the radio sound may be distorted. Keep the battery and battery charger at least 1 m away from radios when in use.
- Noise may be emitted when using the battery charger, but this is not a malfunction.

### ■ When carrying the camera recorder, be careful not to drop it.

- Strong shocks will damage the camera recorder body and it may not operate properly.
- If you carry the camera recorder, use a grip strap or shoulder strap and handle it carefully.

### ■ Do not apply insecticide or volatile materials to the camera recorder.

- If insecticide or volatile materials come into contact with the camera recorder, the camera recorder body may warp and the paint may come off.
- Do not allow the camera recorder to remain in contact with rubber or vinyl objects for a long period of time.

### ■ After using the camera recorder, either remove the battery or disconnect the AC cable from the power outlet.

### ■ Battery characteristics

The battery is a rechargeable lithium-ion battery. It produces electrical energy via an internal chemical reaction. This chemical reaction is easily influenced by the surrounding temperature and humidity, so the effective usage time of the battery is reduced when the surrounding temperature is hot or cold. When used in extremely low temperature environments, the effective usage time is approximately five minutes.

When the battery is in an extremely hot environment, its protective function will operate and the camera recorder cannot be used temporarily.

### ■ After using the camera recorder, be sure to remove the battery.

Be sure to remove the battery from the camera recorder. (If the battery is left in the camera recorder, it will continue to consume a small amount of electric current even when the power is turned off)

If the battery is left inside the camera recorder for a long time, it will over discharge and may become unusable even if it is recharged.

Do not remove the battery when the power is turned on.

Turn off the power and remove the battery after the operation lamp goes completely out.

### ■ Take proper care of the battery terminal.

Do not allow dust or foreign objects on the battery terminal.

Also, if you drop the battery by mistake, make sure that the battery body and the terminal are not warped.

Inserting a deformed battery into the camera recorder or attaching it to the battery charger may cause damages on the camera recorder or battery charger.

### ■ Cautions when throwing memory cards away or transferring them to others

Formatting memory cards or deleting data using the functions of the camera or a computer will merely change the file management information: it will not completely erase the data on the cards. When throwing these cards away or transferring them to others, either physically destroy them or use a data deletion program for computers (commercially available) to completely erase the data. Users are responsible for managing the data stored in their memory cards.

### ■ LCD monitor and viewfinder

- If the same image or letters are allowed to be displayed on the LCD monitor for a long time, the image may be burned into the screen. It will return to normal after leaving the camera recorder turned off for several hours.
- Condensation sometimes forms on the LCD panel of the LCD monitor in locations subject to extreme temperature differences. If this happens, wipe with a soft, dry cloth.
- If the camera recorder is very cold, the LCD monitor will be slightly darker than normal immediately after the power is turned on. The screen will return to its regular brightness when the temperature inside increases.

- Since the viewfinder of the camera uses organic EL, if the same image or letters are allowed to be displayed for a long time, the image may be burned into the screen. There is no problem with the recorded images.  
Switch the screen by turning off the screen or by using the eye sensor, etc.
- The LCD monitor and viewfinder (organic EL) are highly-precisely managed so that at least 99.99% of the dots are effective pixels and 0.01% or less are invalid pixels and always lit. This is not a malfunction and it has no effect whatsoever on the recorded images.

■ **Do not point the eye piece of the lens and viewfinder at the sun.**

Doing so might damage the components inside.

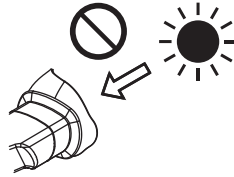

■ **Protective cap for the terminal**

Place a protective cap on connection terminals not being used.

■ **GPS**

GPS (Global Position System) satellite is managed by the United States Department of State and its precision is sometimes intentionally changed. Position it in a location where there is a good view of the sky and there is no influence of obstacles such as roofs and trees, etc. Depending upon the surrounding environment and the time, it may take a long time to position and errors may be larger.

■ **Caution regarding laser beams**

The MOS sensor may be damaged if the MOS sensor is subjected to light from a laser beam. Take sufficient care to prevent laser beams from striking the lens when shooting in an environment where laser devices are used.

■ **Note the following points.**

- If you prepare to record important images, always shoot some advance test footage to verify that both pictures and sound are being recorded normally.
- Should video or audio recording fail due to a malfunction of the camera or the P2 cards used, we will not assume liability for such failure.
- Set up or check the calendar and time zone before recording (Setting the date/time of the internal clock). These settings have an effect on the management and playback order for recorded contents.

■ **Software information about this product**

- 1 This product includes software licensed under GNU General Public License (GPL) and GNU Lesser General Public License (LGPL), and customers are hereby notified that they have rights to obtain, re-engineer, and redistribute the source code of these software.
- 2 This product includes software licensed under MIT-License.
- 3 This product includes software developed by the OpenSSL Project for use in the OpenSSL Toolkit (<http://www.openssl.org/>).
- 4 This product includes software licensed under OpenBSD License.
- 5 This product includes PHP, freely available from <http://www.php.net/>.
- 6 This software is based in part on the work of the Independent JPEG Group.
- 7 This product includes software licensed under the MOZILLA PUBLIC LICENSE.

For details on these descriptions (originally provided in English) and how to obtain the source code, visit the following website.

<http://pro-av.panasonic.net/>

We do not accept inquiries about the details of the source code obtained by the customer.

■ **Precautions when installing USB drivers**

For the latest information on the driver, visit the following website.

<http://pro-av.panasonic.net/>

- Install the required driver into your computer from the website.
- For installation procedure of the driver, refer to the installation manual on the website.

## Use of the camera on a system

Parts other than the camera are optionally available. Use the following recommended parts.

### Basic configuration devices

Equipment necessary for shooting with the camera, such as batteries, etc.

Part name	Part No.	Remark
Super-directional electret stereo microphone (phantom +48V)	AG-MC200G	"Attaching the front microphone" (page 30)
Battery	VW-VBD58 (7.2 V, 5800 mAh: Product comparable to the included battery) CGA-D54/CGA-D54s (7.2 V, 5400 mAh)	"Attaching and removing the battery" (page 26)
SD memory card* P2 memory card* microP2 memory card*	Visit the support desk at the website*	"P2 card" (page 33)

\* For the latest information on P2 cards and SD memory cards that are not described in the Operating Instructions, visit the support desk at the following website:  
<http://pro-av.panasonic.net/>

### Expanded configuration devices

You can also use the following devices in addition to the basic configuration devices.

Part name	Part No.	Remark
Wireless module	AJ-WM30	"For wireless LAN" (page 175)
Remote Operation Panel	AK-HRP200G	"Connecting to the remote operation panel (AK-HRP200G)" (page 170)

## What you can do with this camera

This camera is a P2 hand-held camera recorder with the following features.

- The camera has an optical 22x cam-type zoom and a newly-developed 1/3-type 2.2 million pixel 3MOS sensor with high sensitivity F11 (59.94 Hz)/F12 (50 Hz) and low noise.
- In addition to AVC-Intra 200/AVC-Intra 100/AVC-Intra 50, as a recording codec, the camera also has a low-rate and full HD (1920×1080, 4:2:2, 10-bit) image quality AVC-LongG 50/AVC-LongG 25, and is also capable of long time recording with AVC-LongG 12 (4:2:0, 8-bit).
- It is compatible with both microP2 memory cards and P2 memory cards.
- It supports progressive full frame rate shooting in 1080/60P, 1080/50P, 720/60P, and 720/50P, output of 3G SDI/HDMI, and operations using AVC proxy video.
- In addition to metadata input and playlist editing by using both wired and wireless LAN connections, you can send proxy files to the network server by connecting 4G/LTE USB modem (optional).
- Video streaming transmission is supported. You can distribute live stream while recording video in a memory card.

### Recording to the memory card

#### P2 card

The following can be recorded on the P2 card:

- HD/SD recording
- AVC Ultra system codec support
- Simultaneous recording (microP2 memory card only)
- Background recording (microP2 memory card only)
- Dual codec recording
- Variable frame rate
  - Slow & quick motion recording

#### SD memory card

Settings for user files and scene files, etc. can be stored in and loaded from the SD memory card. In addition, proxy video can be recorded.

### Linking to external devices

#### USB device mode

Data (files) for performing nonlinear editing on a computer are transferred.

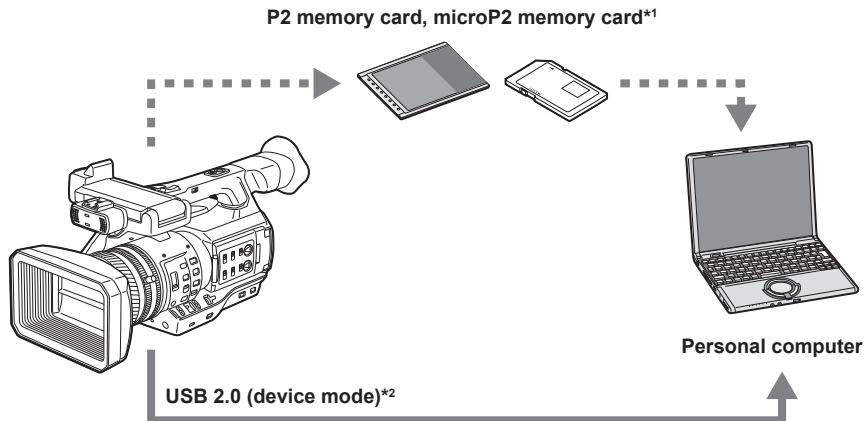

\*1 P2 memory cards and microP2 memory cards are optionally available. They are not supplied with the camera.

\*2 The USB 2.0 cable is not supplied with the camera. Prepare a commercial USB 2.0 cable (double-shielded for noise suppression).

#### USB host mode (<USB3.0 HOST> terminal connection)

The camera directly controls the hard disk drive to transfer data.



\* A USB 3.0 cable is not supplied with this product. Use a commercially sold USB 3.0 cable (with double shielding for noise reduction).

## Connecting to the remote operation panel (AK-HRP200G)

You can remote control some functions by connecting the remote operation panel AK-HRP200G (optional) using a LAN cable.

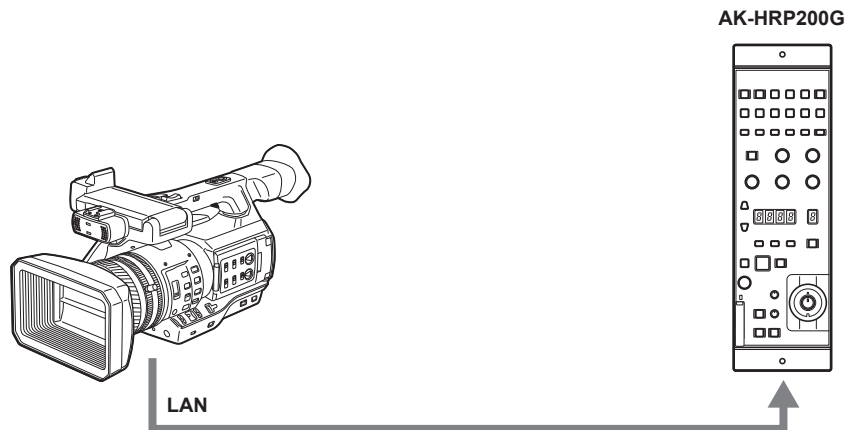

## Connecting to monitor

A monitor can be connected to output images.

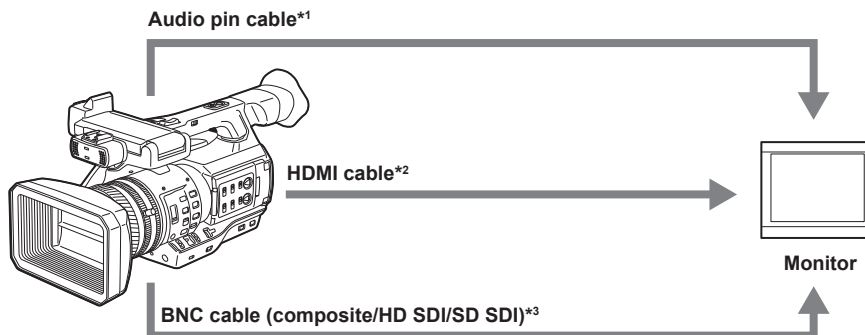

\*1 Cables are optionally available. They are not supplied with the camera.

\*2 Use an HDMI cable (optional) with double shielding. For the HDMI cable, using Panasonic HDMI cable is recommended.

\*3 For the BNC cable (optional) connected to the <SDI OUT> terminal, prepare a double-shielded cable equivalent to 5C-FB.

## Connecting to the network

### Wired LAN connection

The following operations are available on your computer via LAN terminal:

- Camera status check
- Thumbnail image check
- Proxy playback
- Download of proxy file/clip management information
- Displaying/editing of metadata
- Adding/deleting of metadata (shot mark or text memo)
- Camera remote control (collective operations of recording control and time code/user bits)

In addition, the following operations are available via the LAN terminal.

- Transferring of clips with the FTP client function
- Remote control function using the Remote Operation Panel (AK-HRP200G)

### Connection using wireless LAN and 4G/LTE

Attaching the wireless module AJ-WM30 (optional) to the <USB2.0 HOST> terminal (sub-host) of the camera allows you to connect the camera via wireless LAN (IEEE 802.11).

The following operations are available using your tablet, smartphone, and computer.

- Camera status check
- Thumbnail image check
- Proxy playback
- Displaying/editing of metadata
- Adding/deleting of metadata (shot mark or text memo)
- Camera remote control (collective operations of recording control and time code/user bits)

In addition, clips can be transferred by the FTP client function via wireless LAN (access point connection) or 4G/LTE.



## Chapter 2 **Description of Parts**

---

This chapter describes the names, functions, and operations of parts on the camera.

## Left side

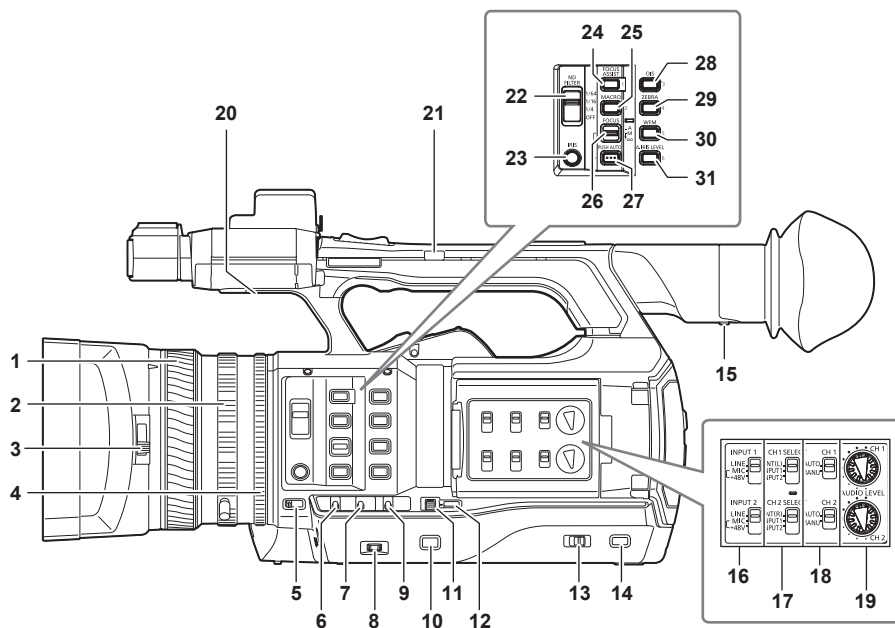
**1 Focus ring (page 46)**

Focus manually when the <FOCUS> switch is set to <M>.

**2 Zoom ring (page 53)**

Adjust the zoom manually when the <ZOOM> switch is set to <MANUAL>.

**3 Lens cover switching lever (page 29)**

Open/close the lens cover.

**4 Iris ring (page 46)**

Adjust the lens iris manually when the manual iris is set with the <IRIS> button.

**5 <ZOOM> switch (page 53)**

Select the operation of the zoom.

<SERVO>: You can use the motor-driven zoom using the zoom lever.

<MANUAL>: You can operate the zoom ring manually to adjust the angle of view.

**6 <DISP/MODE CHK> switch (page 72)**

This is the spring switch to check the status of the shooting, etc.

- Push this switch towards the <OFF> side to clear all displays except the display of the operation status, frame display such as an area, counter, marker, and safety zone.

- Push this switch towards the <CHK> side to display all information such as setting status of the functions for the shooting, the list of functions assigned to the USER buttons on the LCD monitor during shooting stand-by or shooting. Each time the switch is pushed towards the <CHK> side, the display of the status switches in turn.

**7 <GAIN> switch (page 46)**

Switch the brightness of the screen according to the lighting conditions under which you are shooting.

**8 <F.AUDIO LEVEL> dial (page 63)**

In the following conditions, the recording levels for the audio channels 1 to 4 can be adjusted.

- When the <CH1>/<CH2> switch is set to <MANU>

- When [AUTO LEVEL CH3]/[AUTO LEVEL CH4] is set to [OFF] in the main menu → [AUDIO SETUP] → [RECORDING CH SETTING]

Assignment of audio channels 1 to 4 can be performed in the main menu → [AUDIO SETUP] → [RECORDING CH SETTING] → [FRONT VR SELECT].

**9 <WHITE BAL> switch (page 50)**

Select the method for adjustment of the white balance.

<PRST>: Set the white balance to the preset value. Each time the <AWB> button is pressed, [3200K], [5600K], and [VAR] are toggled.

<A>/<B>: Select when using the stored value of the adjustment of the white balance.

**10 <MENU> button (page 124)**

Press this button to display [USER MENU]. Press this button for 3 seconds or more to display the main menu. Press it again to return to the original image.

**11 <SEL/PUSH SET> dial button (page 124)**

Move, select, and set the items in the setting menu while the setting menu is displayed.

Set the preset values of the shutter, synchro scan, variable frame rate value, and white balance.

**12 <MODE/MENU CANCEL> button (page 58)**

- When the setting menu is not displayed, each press of the button switches modes to change the variable value of shutter speed, variable frame rate, and white balance.

- When the setting menu is displayed, setting of the menu items is canceled and the previous screen is displayed.

**13 <AUTO/MANUAL> switch**

Select the method to adjust the focus, gain, iris, white balance, and shutter speed at shooting. You can set the function to assign to <AUTO> in the main menu → [AUTO SW].

<AUTO>: Adjust automatically. (Auto mode)

<MANUAL>: Adjust manually. (Manual mode)

**14 <SLOT SEL> button**

Select the microP2 memory card slot for the target of recording.

This button can be used as the USER button (USER7). (page 37)

**15 Diopter adjustment lever (page 40)**

Adjust the diopter scale so that the viewfinder screen can be viewed clearly.

**16 <INPUT 1>/<INPUT 2> switch (page 62)**

Switch audio input signals connected to the <AUDIO INPUT 1>/<AUDIO INPUT 2> terminal.

<LINE>: Select when audio equipment is connected by the line input.

<MIC>: Select when the external microphone is connected.

<+48V>: Select when the external microphone is connected and the microphone needs power supply.

**17 <CH1 SELECT>/<CH2 SELECT> switch (page 62)**

Select the audio to be recorded to audio channel 1/2.

<INT(L)>/<INT(R)>: Record left audio (right audio) of the built-in microphone.

<INPUT1>: Record input signals from the <AUDIO INPUT 1> terminal.

<INPUT2>: Record input signals from the <AUDIO INPUT 2> terminal.

**18 <CH1>/<CH2> switch (page 63)**

Select the method to adjust the input level of audio channel 1/2.

<AUTO>: Adjust automatically.

<MANU>: Adjust using the <AUDIO LEVEL CH1>/<AUDIO LEVEL CH2> dial.

**19 <AUDIO LEVEL CH1>/<AUDIO LEVEL CH2> dial (page 63)**

Adjust the recording level of audio channel 1/2.

**20 Internal speaker**

Output audio during playback.

When connecting the headphones to the headphones terminal, audio from the speaker turns off automatically.

**21 HANDLE ZOOM switch (page 53)**

Select the operation of the zoom lever (handle side).

<FIX>: Zoom in/out with the speed set in the main menu → [SW MODE] → [H.ZOOM SPEED].

<VAR>: Zoom speed changes depending on how strong the lever is pushed. (When pushed gently, the speed becomes slower, and when pushed strongly, it becomes faster.)

<OFF>: The zoom lever does not work.

**22 <ND FILTER> switch (page 46)**

Select the filter to suit the illumination of the subject.

<1/64>: Reduce the amount of light entering the MOS sensor to 1/64.

<1/16>: Reduce the amount of light entering the MOS sensor to 1/16.

<1/4>: Reduce the amount of light entering the MOS sensor to 1/4.

<OFF>: Does not use the ND filter.

**23 <IRIS> button (page 46)**

Select the method for adjustment of the lens iris.

**24 <FOCUS ASSIST> button (page 47)**

Switch on/off the focus assist function.

This button can be used as the USER button (USER1). (page 37)

**25 <MACRO> button (page 46)**

Switch on/off the macro function of the focus.

This button can be used as the USER button (USER2). (page 37)

**26 <FOCUS> switch (page 46)**

Select the focus function.

<A>: Changes to the auto focus mode. Adjust the focus automatically.

<M>: Changes to the manual focus mode. Control the focus ring manually to adjust the focus.

<∞>: Changes to the manual focus mode after the focus distance is set to infinity.

This is the spring switch. Even when the <FOCUS> switch is pushed towards the <∞> side, the switch returns to the <M> position.

**27 <PUSH AUTO> button (page 47)**

When the button is pressed in manual focus mode, focus is adjusted automatically while it is pressed.

**28 <OIS> button (page 72)**

Switch on/off the image stabilization function.

This button can be used as the USER button (USER3). (page 37)

**29 <ZEBRA> button (page 71)**

Select the display of either zebra or marker.

This button can be used as the USER button (USER4). (page 37)

**30 <WFM> button (page 73)**

Select whether to display the waveform monitor on the LCD monitor.

This button can be used as the USER button (USER5). (page 37)

**31 <A.IRIS.LEVEL> button**

Switch on/off the auto iris function.

Set the target value of the auto iris level in the main menu → [SCENE FILE] → [A.IRIS LEVEL EFFECT].

This button can be used as the USER button (USER6). (page 37)

## Right side

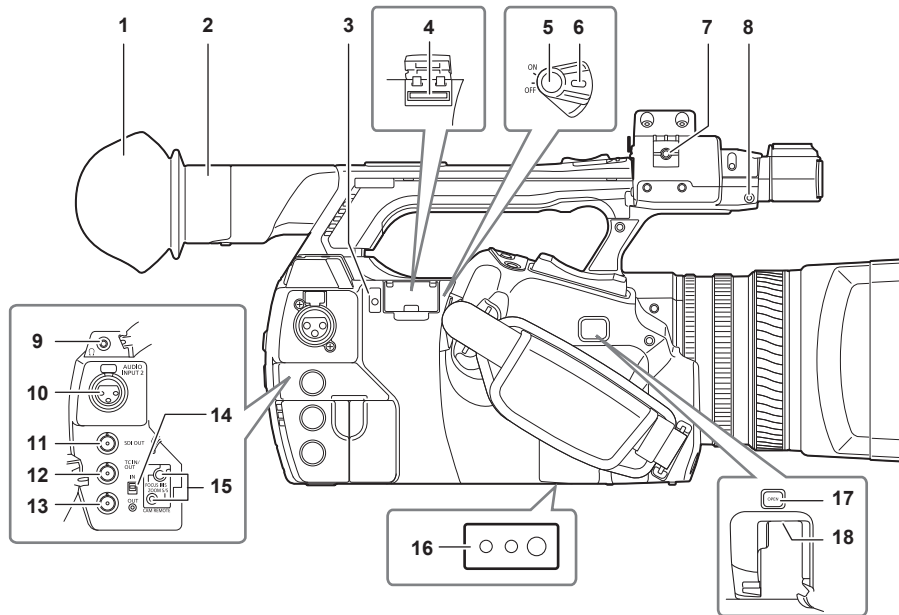

**1 Eye cup (page 29)**

**2 Eye piece**

**3 Busy (active status indication) lamp (page 90)**

Indicate the active status of the SD memory card, and is illuminated when the card is active.

**4 SD memory card slot (page 90)**

This is the insertion slot for the SD memory card (optional). Use the SD memory card for recording/opening the setting menu of the camera, or uploading metadata or proxy recording, etc.

**NOTE**

• Cautions when using SD memory cards

- On the camera, use SD memory cards that conform to the SD standard, SDHC standard, or the SDXC standard. When performing proxy recording, use SDHC memory cards, SDXC memory cards, or SD memory cards with the class description of class2 or higher.
- MMC (Multi Media Card) cannot be used. (Bear in mind that taking pictures may no longer be possible if you use them.)
- When using miniSD/microSD cards with the camera, always install the adaptor specially designed for miniSD/microSD cards. (The camera will not work properly if only the miniSD/microSD adaptor is installed. Make sure that the card has been inserted into the adaptor before use.)
- Use of Panasonic SD memory cards and miniSD/microSD cards is recommended. Be sure to format cards on the camera before use.
- Refer to our support desk at the following website for the latest information not included in these operating instructions.  
<http://pro-av.panasonic.net/>
- SDHC memory cards are a standard that was established in 2006 by the SD Association for large-capacity memory cards that exceed 2 GB.
- SDXC memory cards are a standard that was established in 2009 by the SD Association for large-capacity memory cards that exceed 32 GB.

**5 Recording button (grip side) (page 43)**

Press this button to start recording. Press it again to stop recording.  
Used for direct shooting in thumbnail mode.

**6 Power switch (page 43)**

Switch on/off the power.

**7 Microphone cable clamp (page 30)**

Used for securing the microphone cable.

**8 Pin holder**

Attach the zoom ring pin which is removed from the camera.

**9 Headphones terminal (page 160)**

This is the connecting terminal of headphones for audio monitor.

**10 <AUDIO INPUT 2> terminal (XLR, 3-pin) (page 62)**

Connect the audio equipment or the microphone.

**11 <SDI OUT> terminal (page 103)**

This is the output terminal for HD/SD SDI signals.

**12 <TC IN/OUT> terminal (page 95)**

This is the input/output terminal for time code.

Use the <IN/OUT> switch to select the input or output.

**13 <GENLOCK IN/VIDEO OUT> terminal (page 102)**

This is the input terminal for reference signals when setting the genlock to the camera section. This is the output terminal of the video for monitor.

Use the <IN/OUT> switch to switch the input or output.

**14 <IN/OUT> switch (page 99)**

Switch the input and output of the <TC IN/OUT> terminal and <GENLOCK IN/VIDEO OUT> terminal.

**15 <CAM REMOTE> terminal (page 160)**

Connect the remote control (optional) to control some functions remotely.

**<FOCUS IRIS>**: (3.5 mm mini jack) Control the focus operation and iris operation remotely.

**<ZOOM S/S>**: (2.5 mm mini jack) Control the zoom operation and start/stop operation of recording remotely.

**16 Tripod holes**

Attach the tripod. (bottom)

• Mounting hole size

- 1/4-20 UNC (screw length 5.5 mm or shorter)

- 3/8-16 UNC (screw length 5.5 mm or shorter)

**17 <OPEN> button (page 175)**

Use this button when opening the cover of the <USB2.0 HOST> terminal at the bottom of the button.

**18 <USB2.0 HOST> terminal (sub-host) (page 175)**

This is the terminal for the wireless LAN. Mount the wireless module AJ-WM30 (optional).

## Front side, rear side

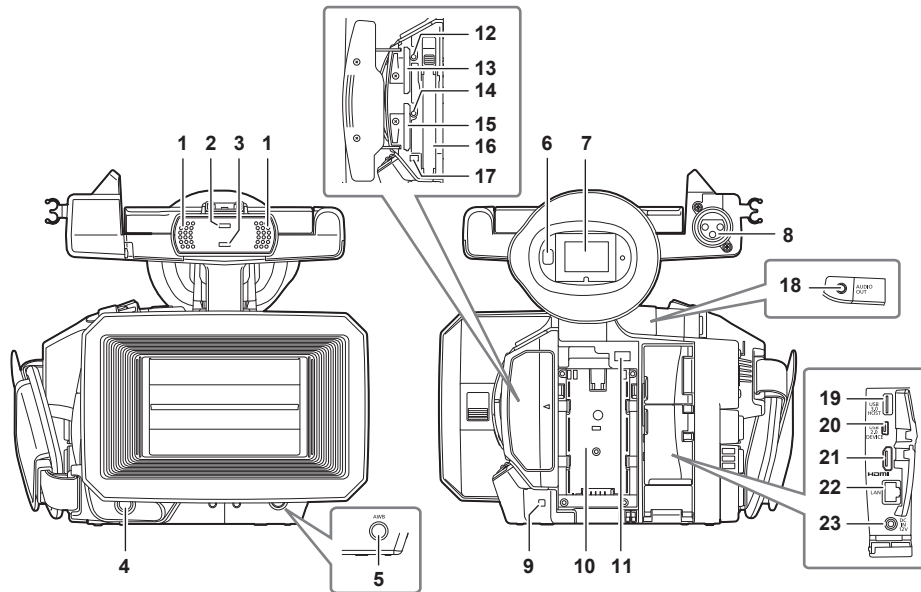

- 1 Built-in microphone (page 62)**  
This is the built-in stereo microphone.
- 2 Light sensor**  
Detects indoor and outdoor light.
- 3 Front tally lamp (page 41)**  
Lights during shooting. This lamp will blink when the battery level becomes low.
- 4 Recording button (front side) (page 43)**  
Press this button to start recording. Press it again to stop recording.  
The operation of this button can be forbidden by the main menu → [SW MODE] → [FRONT REC].
- 5 <AWB> button (page 50)**  
Press this button to adjust the white balance. Press it for two seconds or more to adjust the white balance and then black balance.
- 6 Eye sensor (page 40)**  
Bring your eyes closer to display the screen on the viewfinder.

### NOTE

- The eye sensor may not work properly depending on the shape of glasses in use, how you hold the camera, or by hitting the strong light around the eye piece.

- 7 Viewfinder (page 40)**
- 8 <AUDIO INPUT 1> terminal (XLR, 3-pin) (page 30)**  
Connect the audio equipment or the microphone.
- 9 Rear tally lamp (page 41)**  
Light during shooting. This lamp will blink when the battery level becomes low.
- 10 Battery attachment (page 26)**
- 11 Battery release button (page 26)**  
Remove the battery.
- 12 microP2 memory card 1 access LED (page 34)**  
Indicate the access status of recording and playback of the card inserted in the microP2 memory card slot 1.
- 13 microP2 memory card slot 1 (page 33)**
- 14 microP2 memory card 2 access LED (page 34)**  
Indicate the access status of recording and playback of the card inserted in the microP2 memory card slot 2.
- 15 microP2 memory card slot 2 (page 33)**
- 16 P2 memory card slot (page 33)**
- 17 P2 memory card access LED (page 34)**  
Indicate the access status of recording and playback of the card inserted in the P2 memory card slot.
- 18 <AUDIO OUT> terminal (page 160)**  
Output audio signals recorded to audio channel 1/2.
- 19 <USB3.0 HOST> terminal (host) (page 162)**  
Connect external hard disk drive, etc.
- 20 <USB2.0 DEVICE> terminal (device) (page 162)**  
Connect to a computer with the USB 2.0 cable to transfer data.
- 21 <HDMI OUT> (monitor output) terminal (page 160)**  
This is the output terminal of the video for monitor.



**22 <LAN> terminal (page 176)**

Connect the LAN cable.

**23 <DC IN 12V> terminal (page 26)**

This is the input terminal for the external power supply. Connect the supplied AC adaptor.

## Top side

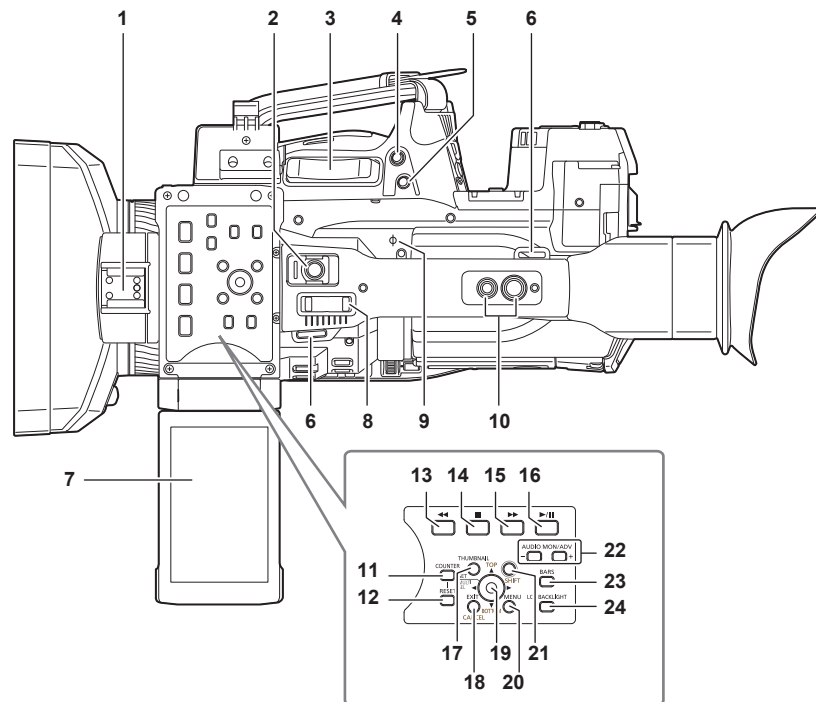

- 1 Light shoe**  
Attach the video light.
- 2 Recording button (handle side) (page 43)**  
Press this button to start recording. Press it again to stop recording.  
This includes hold mechanism.
- 3 Zoom lever (grip side) (page 53)**  
Adjust the zoom of an image.  
<T>: Zoom in the image.  
<W>: Zoom out the image.
- 4 <IRIS> button (page 46)**  
Select the method for adjustment of the lens iris.  
This button can be used as the USER button (USER8). (page 37)
- 5 <REC CHECK> button (page 43)**  
Press this button while recording is suspended, to play back the video and audio of the most recent clip for approximately three seconds.
- 6 Shoulder strap attachment (page 28)**  
Attach the shoulder strap.
- 7 LCD monitor (page 39)**
- 8 Zoom lever (handle side) (page 53)**  
Adjust the zoom of an image.  
<T>: Zoom in the image.  
<W>: Zoom out the image.
- 9 Focal plane index <Φ>**  
Indicate the focal plane of the MOS sensor.  
It provides a reference for measuring the accurate focal distance from the subject.
- 10 Handle mounting holes**  
Mount the handle.
  - Mounting hole size
    - 1/4-20 UNC (screw length 5.5 mm or shorter)
    - 3/8-16 UNC (screw length 5.5 mm or shorter)
- 11 <COUNTER> button (page 100)**  
Switch the display item of the counter.
- 12 <RESET> button**  
Reset the display of the time counter.
- 13 <◀▶> button**  
This works when the thumbnail screen is displayed.  
Press this button during a pause to perform fast-reverse playback.  
Press this button during playback to perform 4x speed reverse playback.  
If it is pressed with playback paused, the clip being played back is paused at its start point (cued state).

**14 <■> button**

This works when the thumbnail screen is displayed.  
 Press this button to stop playback.  
 Press this button when you stop interval recording or one-shot recording, or when you end combining to the clip of one-clip recording.

**15 <▶▶▶> button**

This works when the thumbnail screen is displayed.  
 Press this button during a pause to perform fast playback.  
 Press this button during playback to perform 4x speed playback.  
 If it is pressed with playback paused, the clip being played back is paused at the start point of the next clip (cued state).

**16 <▶/||> button**

This works when the thumbnail screen is displayed.  
 Press this button to view playback image.  
 Press it during playback to pause playback.

**17 <THUMBNAIL> button (page 107)**

Press the button to display the thumbnail screen on the LCD monitor and viewfinder. Press it again to return to the regular display.

**18 <EXIT>/<CANCEL> buttons (page 109)**

Restore the display to the previous state while the setting menu or property screen is displayed.  
 Press this button while holding down the <SHIFT> button to act as the cancel button. This is convenient, for example, for batch-canceling clip selections.

**19 Control stick (page 109)**

Use this button to select a thumbnail or to perform operations of menus and area mode function.

**20 <MENU> button (page 124)**

Press this button to display [USER MENU]. Press this button for 3 seconds or more to display the main menu.  
 Press it while the thumbnail is displayed to display the operation screen of the thumbnail menu, and clips can be deleted.

**21 <SHIFT> button (page 109)**

Use this button together with the control stick or other buttons.

- Press the control stick upward/downward while holding down the <SHIFT> button.  
 This moves the cursor to the thumbnail of the clip at the start or the end on the thumbnail screen.
- Press the control stick while holding down the <SHIFT> button.  
 This selects all clips from the previously selected clip up to the clip at the cursor position.
- Press the <EXIT>/<CANCEL> buttons while holding down the <SHIFT> button.  
 This works as the cancelation function. (page 23)

Operations with the <SHIFT> button held down are displayed in orange at each operation section.

**22 <AUDIO MON/ADV> button (page 106)**

<+>: When pressing during playback, the audio volume of the monitor is increased. When pressing during pause, frame-by-frame play is performed.  
 <->: When pressing during playback, the audio volume of the monitor is decreased. When pressing during pause, frame-by-frame rewind is performed.

**23 <BARS> button (page 72)**

Switch on/off the color bar. The color bar is interlocked with the test tone (1 kHz).

**24 <LCD BACKLIGHT> button (page 39)**

Select the brightness of the backlight of the LCD monitor.

## Chapter 3 **Preparation**

---

Before you use the camera, mount the battery following the procedures in this chapter. The mounting of accessories is also described in this chapter.

## Power supply

A battery or AC adaptor can be used as the power supply.

### Charging the battery

The battery is not charged at the time of purchase. Fully charge the battery in the battery charger before using the battery. It is recommended that you have one extra battery.

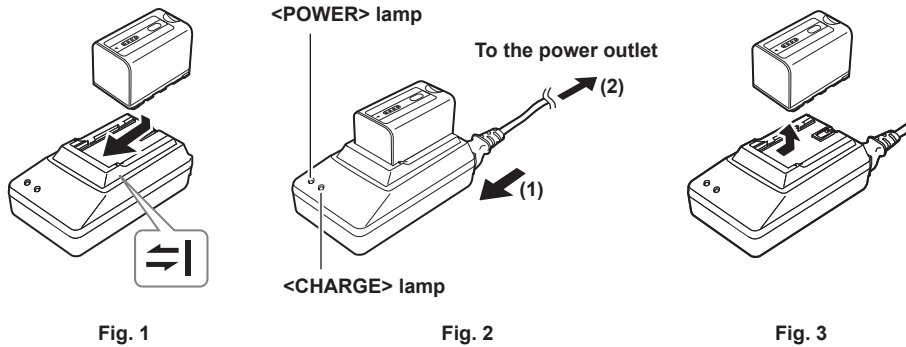

#### 1 Place the battery horizontally along the ⇄| mark in the battery charger and slide it in. (Fig. 1)

Press it in firmly.

#### 2 Connect an AC cable. (Fig. 2)

Connect in the order shown in the figure.

- <POWER> lamp
  - Once the AC cable is connected, the lamp will light up.
- <CHARGE> lamp
  - Lit: Charging.
  - Not lit: Charging is complete.
  - Flashing: Reinsert the battery.

#### 3 Slide the battery out to remove it. (Fig. 3)

#### ■ Standard charging time and recording time

Battery parts number	Voltage/capacity	Charging time	Continuous shootable time
VW-VBD58 (supplied)	7.2 V/5800 mAh	Approx. 380 min	Approx. 90 min
CGA-D54/CGA-D54s (optional)	7.2 V/5400 mAh	Approx. 330 min	Approx. 85 min

- The time when the ambient operating temperature is 20 °C and the relative operating humidity is 60%. At other temperature and humidity the charging time may take longer.

#### NOTE

- Continuous recordable time is applied under the following conditions. If you use the camera in other conditions, continuous shootable time will shorten.
  - With the LCD monitor open
  - When the main menu → [OUTPUT SEL] → [SDI OUT] is set to [OFF]
  - When the main menu → [OUTPUT SEL] → [VIDEO OUT] is set to [OFF]
  - With the cable not inserted into the <HDMI OUT> terminal
- The battery and camera recorder will become warm during use or while charging.
- Make sure that batteries are discharged before storing them.
- When stored for long periods of time, it is recommended that you charge batteries once per year and then use up the battery capacity by using the battery in the camera recorder before storing it again.
- When the battery becomes extremely hot or cold, the <CHARGE> lamp will flash several times and charging will automatically begin.
- When the battery is left unused and discharged for a long time, the <CHARGE> lamp will flash several times and charging will automatically begin.
- If the <CHARGE> lamp continues blinking even when the battery is at its optimal temperature, the battery or battery charger may be damaged. Contact a dealer.
- If the battery is warm, it will take longer than usual to charge.
- If you use the battery charger near a radio, the radio sound may be distorted. Keep the battery and battery charger at least 1 m away from radios when in use.
- Noise may be emitted from the battery charger when using the battery charger, but this does not indicate a malfunction.

#### ■ Supplied battery

- Remaining battery level display function
 

The approximate remaining battery level can be checked by looking at the LED display of the battery.

The displayed battery level may be different when the battery is attached to the camera and you are shooting and when the battery is not attached.
- The supplied battery is intended for use only in this camera.
 

Do not use it in other devices.

## Attaching and removing the battery

### Attaching

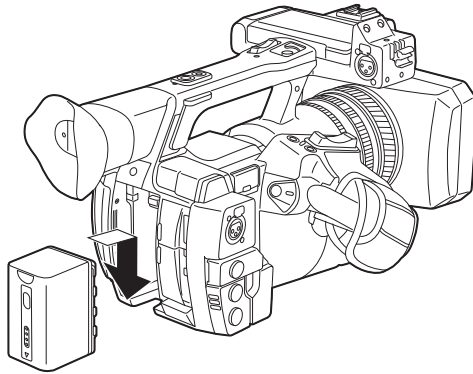

- 1 Insert the battery until you hear it clicks.

### Removing

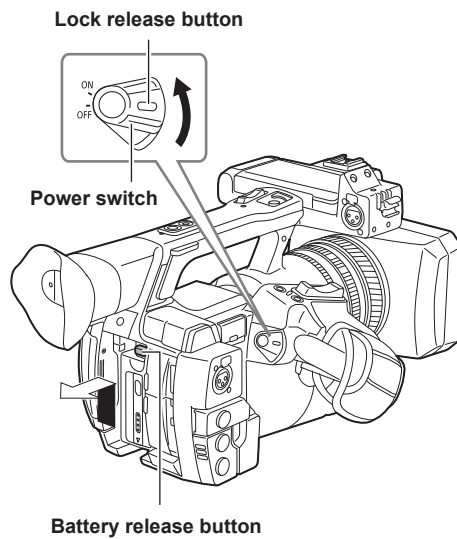

- 1 Turn the power switch to <OFF> while holding down the lock release button.

Make sure that the LCD monitor has gone off.

- 2 Lift up and remove the battery while holding down the battery release button.

Support the battery with your hand so that it does not fall down.

## Using the AC adaptor

### Attaching

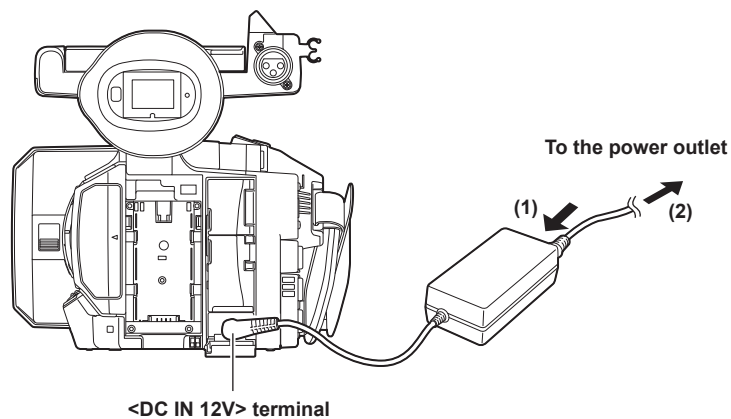

- 1 Connect an AC cable.

Connect in the order shown in the figure.



**2** Connect the AC adaptor to the <DC IN 12V> terminal.

### Removing

**1** Turn the power switch to <OFF> while holding down the lock release button.

Make sure that the LCD monitor has gone off.

**2** Remove the AC adaptor from the <DC IN 12V> terminal.

### NOTE

- When not using the camera, remove the AC cable from the power outlet.
- Use the supplied AC adaptor. Do not use other AC adaptors.
- The AC adaptor can be connected when attaching the battery to the camera. When the AC adaptor is connected, the camera will switch to be powered by the AC adaptor. When removing the AC adaptor, the camera will be powered by the battery.

## Attaching and adjusting accessories

### Adjusting the grip strap

Adjust the grip strap so that it fits the size of your hand.

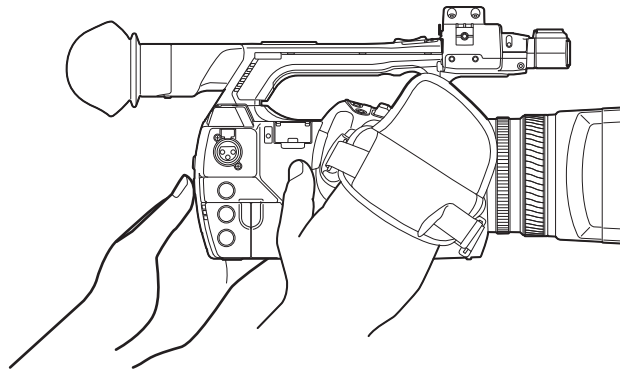

**1** Open the cover and adjust the length of the strap.

**2** Replace the cover.

Attach the cover firmly.

### Attaching the shoulder strap

Attach the shoulder strap to the attachment lugs.

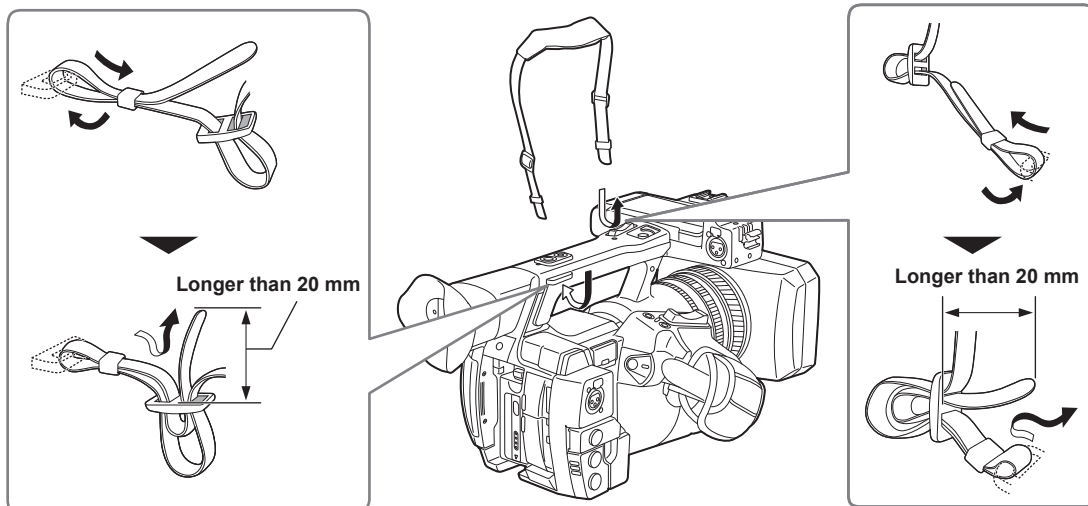

#### NOTE

- Make sure that the shoulder strap is securely attached.

### Attaching the lens hood

#### Removing

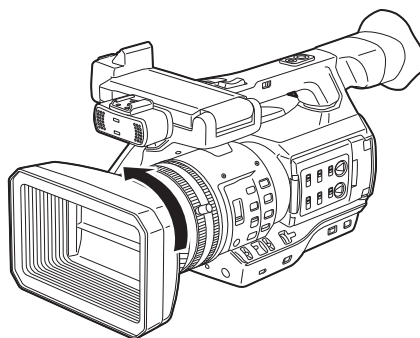

**1** Rotate the lens hood counter-clockwise.

## Attaching

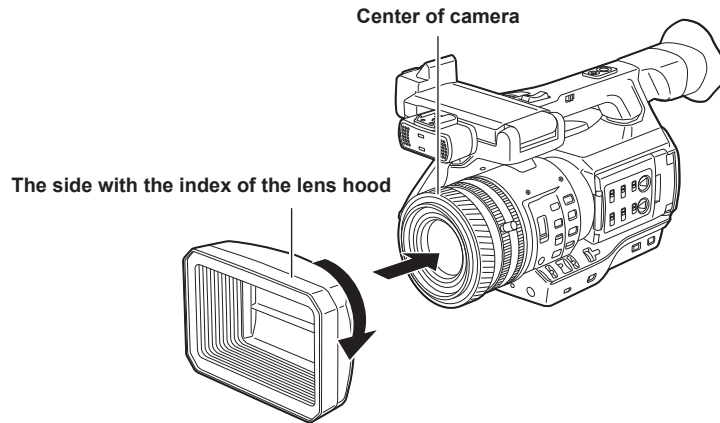

**1** Align the index of the lens hood with the center of the camera body and attach.

Position the lens hood so that the side with the index of the lens hood is facing upwards.

**2** Rotate the lens hood clockwise until it locks in with a click.

## Opening and closing the lens cover

Use the lens cover open/close lever to open and close the lens cover.

Open the lens cover to take videos and photographs.

When not using the camera, close the lens cover in order to protect the lens.

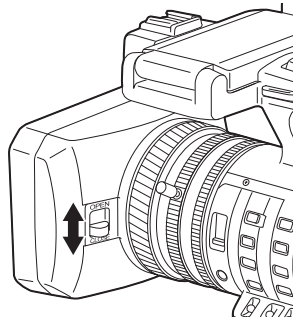

 **NOTE**

- Do not press the lens cover with force. Doing so may damage the lens and lens cover.

## Attaching the eye cup

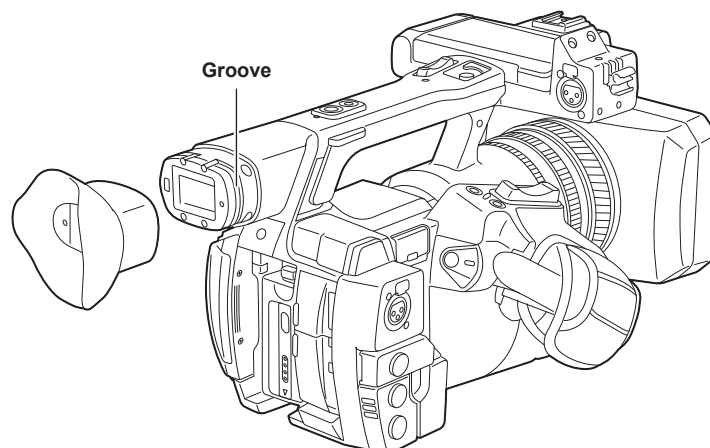

**1** Attach the eye cup by aligning the groove on the attaching part of the eye cup with the inner ridge of the eye cup.

## Attaching the front microphone

Microphones such as a super-directional microphone AG-MC200G (optional) can be attached.

Screws for tapped hole protection are attached on the camera body. Remove those screws when you attach the microphone holder.

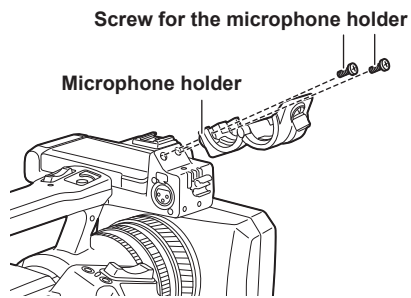

Fig. 1

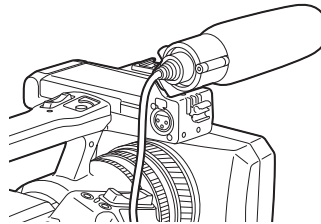

Fig. 2

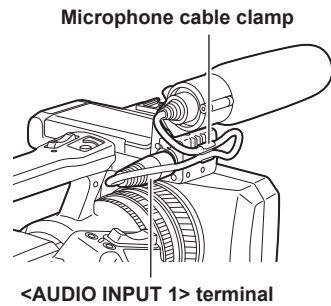

Fig. 3

- 1** Attach the microphone holder. (Fig. 1)
- 2** Attach the microphone and tighten the microphone holder clamping screw. (Fig. 2)
- 3** Connect the microphone connecting cable to the <AUDIO INPUT 1> terminal on the camera. (Fig. 3)
- 4** Secure the microphone connecting cable with the microphone cable clamp.
- 5** Set the <INPUT 1> switch to match the microphone to be connected.

### NOTE

- The microphone holder cannot be fixed with the screws originally attached on the camera. Use the dedicated screws that came with the camera to fix the microphone holder.

## Attaching a tripod

The tripod attachment holes accept 1/4-20 UNC and 3/8-16 UNC screws. Use the hole that matches the diameter of the clamping screw on the tripod.

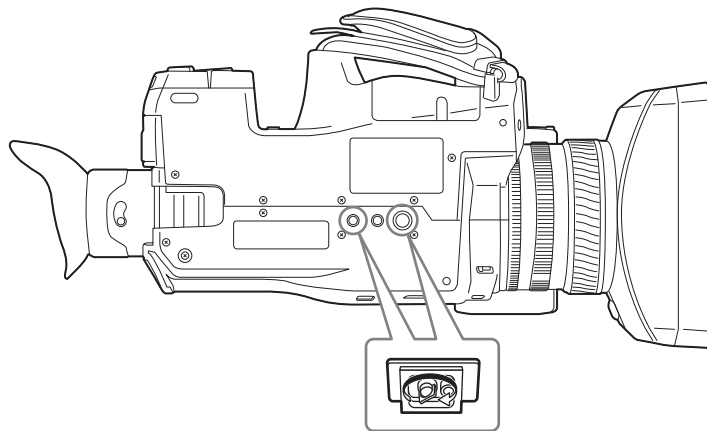

### NOTE

- Use a tripod in safe locations.
- The depth of the tripod attachment hole is 5.5 mm. When attaching the camera to a tripod, do not over-tighten the tripod screw.

## Turning on/off the power

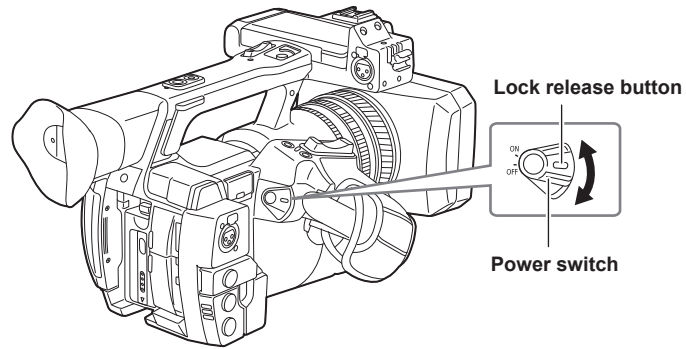

### How to turn on the power

- 1 Align the power switch to <ON> while holding down the lock release button.  
The LCD monitor lights up.

### How to turn off the power

- 1 Align the power switch to <OFF> while holding down the lock release button.  
The LCD monitor goes off.

## Setting the date/time of the internal clock

The value of the time is recorded to content (clips) and affects the thumbnail playback order. Before recording, be sure to check and set the date and time zone.

### 1 Press the <MENU> button for 3 seconds or more.

- The main menu screen is displayed in the viewfinder and on the LCD monitor.

### 2 Select the main menu → [OTHER FUNCTIONS] → [CLOCK SETTING] to set the year, month, day, and time.

For details on the settings menu, refer to “Setting menu basic operations” (page 124).

### 3 Select the main menu → [OTHER FUNCTIONS] → [TIME ZONE] to set the time difference from Greenwich Mean Time.

#### NOTE

- You can correct the date and time of the internal clock from GPS by enabling the GPS function.

#### ■ Time zone table

Time difference	Region	Time difference	Region
00:00	Greenwich	+01:00	Central Europe
-00:30		+01:30	
-01:00	Azores	+02:00	Eastern Europe
-01:30		+02:30	
-02:00	Mid-Atlantic	+03:00	Moscow
-02:30		+03:30	Tehran
-03:00	Buenos Aires	+04:00	Abu Dhabi
-03:30	Newfoundland	+04:30	Kabul
-04:00	Halifax	+05:00	Islamabad
-04:30		+05:30	Bombay
-05:00	New York	+06:00	Dakar
-05:30		+06:30	Yangon
-06:00	Chicago	+07:00	Bangkok
-06:30		+07:30	
-07:00	Denver	+08:00	Beijing
-07:30		+08:30	
-08:00	Los Angeles	+09:00	Tokyo
-08:30		+09:30	Darwin
-09:00	Alaska	+10:00	Guam
-09:30	Marquesas Islands	+10:30	Lord Howe Island
-10:00	Hawaii	+11:00	Solomon Islands
-10:30		+11:30	Norfolk Island
-11:00	Midway Islands	+12:00	New Zealand
-11:30		+12:45	Chatham Islands
-12:00	Kwajalein Atoll	+13:00	
+00:30			

#### NOTE

- Be sure to make this setting before using the camera for the first time. After, do not change the setting during use.
- Clock accuracy is a lunar inequality of approximately  $\pm 30$  seconds with the power off. When accurate time is required, check and reset the time when the power is turned on.
- The internal clock runs for several years on the built-in lithium cell of the camera. When the lithium cell runs low, [BACKUP BATT EMPTY] will be displayed in the viewfinder and LCD monitor screen when the camera is turned on. For details, refer to “Maintenance” (page 192).

## P2 card

### Inserting a P2 card

When using the camera for the first time, be sure to set the time data beforehand. (page 32)

Select and use either of the microP2 or P2 memory card slot on the camera.

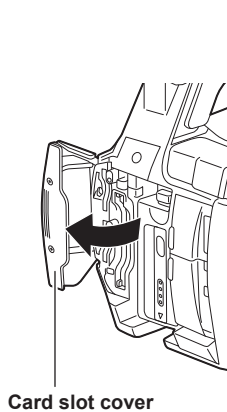

Fig. 1

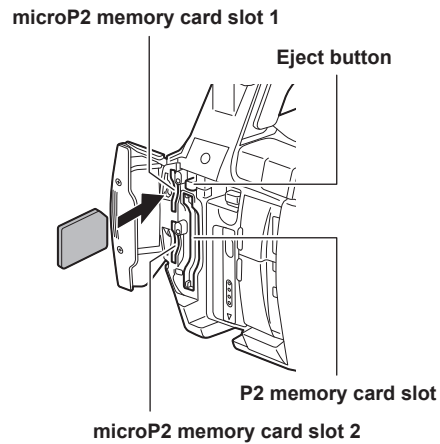

Fig. 2

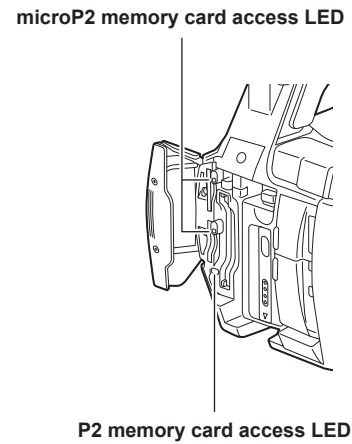

Fig. 3

#### 1 Set whether to use the microP2 memory card slot or the P2 memory card slot.

- 1) Select [REC MEDIA] in the main menu → [RECORDING SETUP].
- 2) When using microP2 memory cards, select [microP2], and when using P2 memory cards, select [P2].

#### 2 Open the card slot cover. (Fig. 1)

#### 3 Insert a card into the card slot. (Fig. 2)

- microP2 memory cards
  - Insert with the label side facing left.
  - There are two microP2 memory card slots.
- P2 memory cards
  - Insert the card with the logo facing left until the eject button pops out.
  - Press the eject button that popped out to the upward.

#### 4 Make sure that the P2 card access LED is lit orange or green. (Fig. 3) (page 34)

When two microP2 memory cards are inserted in the card slots, recording will be performed in order from the microP2 memory card with the smaller slot number. However, regardless of the slot number, if a microP2 memory card is inserted later, that microP2 memory card will be accessed later than the previously inserted microP2 memory cards.

##### • Example: When microP2 memory cards are inserted in two slots

If microP2 memory cards are inserted into two slots, the cards are used as P2 card in the order of the slot number 1 → 2. However, if you remove the microP2 memory card from slot 1 and then insert it again, recording of the microP2 memory card will take place in order from slot 2 → 1.

The microP2 memory card number to be recorded to is maintained even if the camera is turned off. When the camera is next turned on, recording can be continued to the same microP2 memory card as before the camera was turned off.

#### 5 Close the card slot cover.

##### NOTE

- You can also switch the memory card to be recorded by pressing the USER button on which [REC MEDIA] is assigned.
- Be sure to close the card slot cover in order to prevent dropping, dust, and static electricity.
- Be sure to format P2 cards only on a P2 device.
- A microP2 memory card with the microP2 card adaptor (AJ-P2AD1G) attached cannot be inserted into the P2 memory card slot on the camera.
- If SDHC/SDXC memory cards other than microP2 memory cards are used on the microP2 memory card slot, operation is not guaranteed.
- If a microP2 memory card is inserted slowly, [FORMAT ERROR!] or [NOT SUPPORTED!] may be displayed. In such a case, insert the card again.

## Removing a P2 card

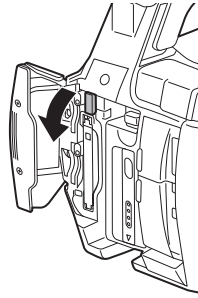

Fig. 1

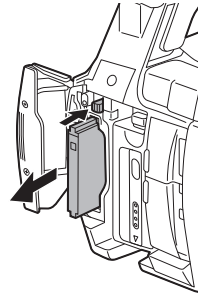

Fig. 2

### 1 Open the card slot cover.

### 2 Remove the card.

- microP2 memory cards
  - Press in the microP2 card further into the camera and let go.
  - The microP2 memory card is released from the card slot, and the microP2 memory card can be removed.
- P2 memory cards
  - Lift the eject button (Fig. 1), and press in. (Fig. 2)

#### NOTE

- After insertion, do not remove the P2 card while it is being accessed or recognized (the P2 card access LED is flashing orange). Doing so may result in a malfunction.
- If the P2 card is removed while being accessed, [TURN POWER OFF] is displayed on the LCD monitor screen or the viewfinder screen, and the tally lamp or other warning is displayed. Also, all P2 card access LEDs flash rapidly in orange. Turn off the power. (page 195)
- If the P2 card is removed while being accessed, clips on it may become irregular. Check the clips and restore them, if required. (page 113)
- If the P2 card being formatted is removed, formatting of the P2 card is not guaranteed. In this case, [TURN POWER OFF] is displayed on the LCD monitor screen or the viewfinder screen. Turn off the power and then back on again, and reformat the P2 card.
- If a P2 card is inserted into another slot during playback, the inserted card is not recognized and the P2 card access LED does not light. The P2 card starts to be recognized when playback ends.
- Even if a P2 card is inserted in a vacant card slot during recording, the P2 card may not be recognized immediately in the following instance:
  - Immediately after a pre-recording
  - Immediately after a recording slot is switched
- The P2 card access LED can be set to continuously off in the main menu → [OTHER FUNCTIONS] → [ACCESS LED]. In this case, turn off the power before removing the card, or after the card is inserted or after operation (recording, playback, etc.) has stopped, and wait for the charging to complete before removing the card.

## Preventing accidental erasure

In order to prevent erasing the recorded contents of the P2 card by mistake, turn the write protect switch on the P2 card to the Protect side (or the LOCK side).

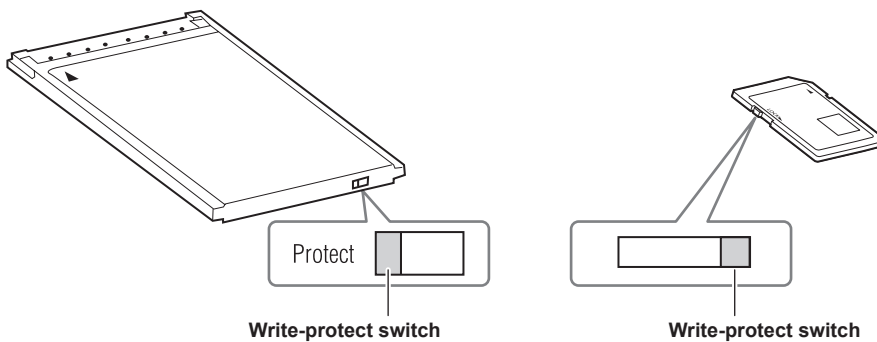

#### NOTE

- Write-protect switch can be switched while the card is being accessed (during recording or playback), but does not take effect until accessing of the card stops.

## P2 card access LEDs and status of P2 cards

P2 card access LED	P2 card status		Mode check display*
Is illuminated green	Recording possible	Reading/writing are both possible.	[ACTIVE]
Is illuminated orange	Recording target	Reading/writing are both possible. The card is currently the recording target (including loop recording).	[ACTIVE]
Flashing orange	Accessing card	Reading/writing are currently being performed.	[ACCESSING]
Flashing orange rapidly	The card is being recognized.	The P2 card is being recognized.	[INFO READING]



## Chapter 3 Preparation — P2 card

P2 card access LED	P2 card status		Mode check display*
Flashing green slowly	Card full	There is no free space on the P2 card. Reading only is possible.	[FULL]
	Write protect	The write-protect switch on the P2 card is at the Protect position. Reading only is possible.	[PROTECTED]
	Unrecordable card	Recording is not possible by the currently set recording format since the SD memory card, etc. is inserted. To record the card, change the recording format or use a P2 card.	[REC IMPOSSIBLE]
	Slot that is not recording target	The card has been inserted into a different slot from the slot ([P2] or [microP2]) that was selected in the main menu → [RECORDING SETUP] → [REC MEDIA].	[FULL]
Off	Card not supported	This card cannot be used on the camera. Replace the card.	[NOT SUPPORTED]
	Illegal format	The P2 card is not properly formatted. Reformat the card.	[FORMAT ERROR]
	No card	The P2 card is not inserted. The card is waiting to be recognized.	[NO CARD]
	Unauthenticated card	This microP2 memory card cannot be authenticated. Select the main menu → [CLIP] → [AUTHENTICATE], and enter the password. For details, refer to “Manual CPS authentication” (page 120).	[AUTH NG]

\* Mode check is displayed on the LCD monitor screen or the viewfinder screen. For details, refer to “Screen status display” (page 151).

### P2 card recording time

#### ■ P2 cards supported on the camera

Optional P2 memory cards and microP2 memory cards with a capacity of 4 GB to 64 GB can be used with the camera.

#### NOTE

- AJ-P2C002SG (2 GB) cards cannot be used.
- When AVC-Intra 200 and AVC-Intra 100 in 1080/59.94P or 1080/50P mode is selected, you cannot record to the following P2 cards.
  - P2 memory cards of R, A, or E series
- The driver installed on the camera may be required to be updated depending on the type of P2 card. (page 199)
- Refer to our support desk at the following website for the latest information not included in these operating instructions.  
<http://pro-av.panasonic.net/>

#### ■ P2 card recording times

(Example when a 64 GB card is used)

System mode	Recording format (codec)	Recording time
1080P	AVC-Intra 200 30PN AVC-Intra 200 25PN AVC-Intra 100	Approx. 32 min
	AVC-LongG 25	Approx. 128 min
	AVC-LongG 12	Approx. 256 min
1080i, 720P	AVC-Intra 200	Approx. 32 min
	AVC-Intra 100	Approx. 64 min
	AVC-Intra 50	Approx. 128 min
	AVC-LongG 50	Approx. 128 min
	AVC-LongG 25	Approx. 256 min
	AVC-LongG 12	Approx. 512 min
	DVCPRO HD	Approx. 64 min
480i, 576i	DVCPRO50	Approx. 128 min
	DVCPRO	Approx. 256 min
	DV	Approx. 256 min

#### NOTE

- The above table shows values for regular recording. With native recording, even longer recording times are available depending on the system mode.
- In the case of 32 GB P2 cards, the recording time becomes 1/2 of the above recording times, in the case of 16 GB P2 cards, the recording time becomes 1/4, and in the case of 8 GB P2 cards, the recording time becomes 1/8.
- Indicated capacities include management and other area, so the space available for recording is less than the values in the table above.

### Dividing clips recorded on P2 cards

If P2 cards with a capacity of 8 GB or more are used on the camera, recording is automatically continued as another clip when a single continuous recording time exceeds the following times. When thumbnails for clips are handled (displayed, deleted, restored, etc.) on P2 devices, they can be handled as a single clip. Clips may be displayed as separate clips in nonlinear editing software and on a computer. When recording on microP2 memory cards that exceed 32 GB in AVC-LongG codec, recording can be continued as the same clip by selecting [ONE FILE] from the main menu → [RECORDING SETUP] → [FILE SPLIT].

Recording format (excluding native recording)	Continuous recording time
AVC-Intra 200 (720P) AVC-Intra 100 (1080P)	Approx. 3 min
AVC-Intra 100 (1080i) DVCPRO HD	Approx. 5 min
AVC-LongG 50 AVC-Intra 50 DVCPRO50	Approx. 10 min
AVC-LongG 25 DVCPRO DV	Approx. 20 min
AVC-LongG 12	Approx. 40 min

## CPS (Content Protection System)

The microP2 memory card supports the security function “Content Protection System” that allows encryption formatting to prevent data leak to third parties.

To use the CPS function, set a CPS password to the camera, and enable the microP2 memory card authentication and encryption formatting functions. An encrypted microP2 memory card will be automatically recognized between devices where the same CPS password is set, and recording and playback of the microP2 memory card are enabled. For details, refer to “Setting CPS password” (page 119).

### NOTE

- Setting or deleting of CPS can be performed in the main menu → [CLIP] → [PROPERTY] → [CPS PASSWORD].
- Up to 16 characters can be input.
- The encrypted microP2 memory card is not recognized on the SD card slot in a computer.
- If the card is unable to be recognized, authenticate with the correct password or format and use the card as recording media. Recording data on the card failed to be recognized cannot be checked. Do not perform any operation other than manual authentication and formatting with the failed card inserted.
- To access the encrypted card from a computer in the USB device mode, authenticate the encrypted card with P2 Viewer Plus.

## How to handle data recorded on P2 cards

P2 cards are semiconductor memory cards that are used as the recording medium in the professional video production and broadcasting devices that make up the DVCPRO P2 series.

- Since data recorded in the P2 format is in a file format, they have excellent compatibility with computers. The file structure is a unique format, which in addition to video and audio data in MXF files contains various other important information items. The folder structure links data recorded in the P2 format as shown below.

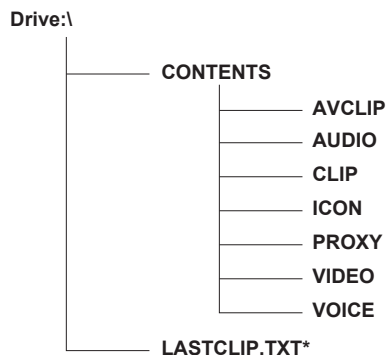

**All these folders are required.**

**If even part of this information is modified or deleted, the data may no longer be recognized as P2 data, or the card may no longer be able to be used with P2 devices.**

**\*This is the file to which the information of the final clip that was recorded with the P2 device is written.**

### NOTE

- P2 cards formatted on devices other than microP2 memory card compatible devices do not have the AVCLIP folder. For P2 cards without the AVCLIP folder, the folder will automatically be created when recording is performed on microP2 memory card compatible devices.
- When transferring data from a P2 card to a computer, or when rewriting data saved on a computer back to a P2 card, to prevent data loss be sure to download the special “P2 Viewer Plus” software. For details on downloading P2 Viewer Plus and the operating environment, visit the support desk at the following website:  
<http://pro-av.panasonic.net/>
- Follow the steps below to use general IT tools such as Microsoft Windows Explorer or Apple Finder to transfer the data to a computer.
  - Transfer the corresponding CONTENTS folder and LASTCLIP.TXT file together as a set.
  - Do not transfer individual files from the CONTENTS folder.
  - When copying, copy the LASTCLIP.TXT file at the same time as the CONTENTS folder.
  - When transferring the data in multiple P2 cards to a computer, create a folder for each P2 card to prevent clips with the same name from being overwritten.
  - Do not delete data from the P2 card.
  - Be sure to format P2 cards on a P2 device or P2 Viewer Plus.

## Assigning functions to the USER buttons

Selected functions can be assigned to USER1 to USER8.

Set the functions to be assigned to [USER1] to [USER8] in the main menu → [USER SW].

Check the setting details using the <DISP/MODE CHK> button.

The following button functions are assigned to USER1 to USER8 as the factory settings. (The numbers of the USER buttons are displayed in the camera.)

- USER1: <FOCUS ASSIST>
- USER2: <MACRO>
- USER3: <OIS>
- USER4: <ZEBRA>
- USER5: <WFM>
- USER6: <A.IRIS.LEVEL>
- USER7: <SLOT SEL>
- USER8: <IRIS>

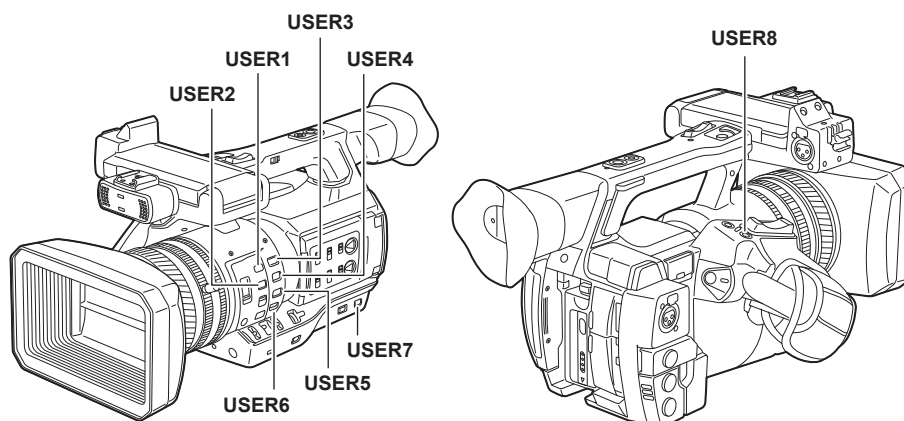

### Selectable functions

Item	Description
[INHIBIT]	Disables assignment of functions.
[SCENE FILE SEL]	Assigns the function to display the screen (the main menu → [SCENE FILE] → [FILE SELECT]) in which users select the scene file.
[LEVEL GAUGE]	Switches the level gauge display function to enabled/disabled.
[LEVEL GAUGE RESET]	Assigns the function to set the level gauge using the current horizontal and vertical directions as reference values. Holding down the assigned button will reset to the factory setting.
[WFM]	Assigns the function for switching the waveform display. Select the waveform display from the main menu → [SW MODE] → [WFM MODE].
[D.ZOOM]	Assigns the digital zoom function. Zooms in on the field angle by 2x, 5x, and 10x vertically and horizontally.
[DRS]	Assigns the dynamic range stretcher function.
[FBC]	Switches the flash band compensation function to enabled/disabled.
[S.GAIN]	Assigns the function that increases the gain to 24 dB or more. Select the gain value from the main menu → [SW MODE] → [SUPER GAIN].
[1S.EXP.]	Enables/disables the one second exposure function.
[ATW]	Switches the auto tracking white balance functions to enabled/disabled.
[ATW LOCK]	Fixes the white balance value when pressing this item while the auto tracking white balance function is activated. Resumes the auto tracking white balance function when pressing again.
[SPOTLIGHT]	Switches the auto iris control function for the spot light to enabled/disabled.
[BACKLIGHT]	Switches the auto iris control function for the backlight compensation to enabled/disabled.
[BLACKFADE]	Assigns the functions that fade out the entire image as black.
[WHITEFADE]	Assigns the functions that fade out the entire image as white.
[A.IRIS LEVEL]	Switches the auto iris setting function to enabled/disabled.
[IRIS]	Assigns the function for switching the auto iris and manual iris.
[Y GET]	Assigns the function for displaying the luminance level of the image at the position indicated by the square marker displayed near the center.
[FOCUS ASSIST]	Switches the manual focus assist display to on/off.
[FOCUS MACRO]	Switches the macro focus setting. You can set the macro function effects in the main menu → [SW MODE] → [MACRO MODE].
[OIS]	Switches the image stabilizer to enabled/disabled.
[FAST ZOOM]	Speeds up the zoom speed when the zoom lever (with the HANDLE ZOOM switch at the handle side set to <VAR>) is pushed in to the end.
[ZEBRA]	Assigns the display function of the zebra pattern and marker.
[EVF ON/OFF]	Assigns the function that forces images to be displayed in the viewfinder.
[PRE REC]	Assigns the function for switching the pre-recording function to enabled/disabled.
[TEXT MEMO]	Assigns the text memo function.

### Chapter 3 Preparation — Assigning functions to the USER buttons

Item	Description
[SHOT MARK]	Assigns the shot mark function.
[DEL LAST CLIP]	Assigns the function to delete the clip shot immediately beforehand.
[SLOT SEL]	Assigns the function for switching the card to record when two or more cards are inserted in the microP2 memory card slot.
[REC MEDIA]	Assigns the function to select the recording target slot between the P2 memory card slot and microP2 memory card slot. This setting is linked to the setting value in the main menu → [RECORDING SETUP] → [REC MEDIA].
[AUDIO MON SEL]	Assigns the function that switches between the display of the audio level meter and the audio channel ([CH1]/[CH2] and [CH3]/[CH4]) of output audio (headphones, built-in speaker, <AUDIO OUT> terminal, and <HDMI OUT> terminal) while the button is held down.
[REC CHECK]	Assigns the recording check function.
[BACKGR REC PAUSE]	Assigns the function to cancel the background recording of slot 2. Hold down the assigned button for approx. five seconds to stop the background recording.
[USB MODE]	Assigns the function for switching the USB device mode or USB host mode to enabled/disabled.
[PLAYLIST]	Assigns the function for switching entering/exiting of the playlist edit mode.

#### NOTE

- The following functions are also turned off when the camera is turned off.  
[WFM]/[D.ZOOM]/[FBC]/[S.GAIN]/[ATW]/[ATW LOCK]/[SPOTLIGHT]/[BACKLIGHT]/[BLACKFADE]/[WHITEFADE]/[Y GET]/[FOCUS ASSIST]/[FAST ZOOM]/[EVF ON/OFF]/[AUDIO MON SEL]/[USB MODE]/[PLAYLIST]
- When [FAST ZOOM] is enabled, the zoom sound becomes louder than usual.

## Adjusting and setting the LCD monitor

### Using the LCD monitor

The LCD monitor of this camera is a 3.5 type. Use either the viewfinder or the LCD monitor depending on your purpose and the shooting conditions.

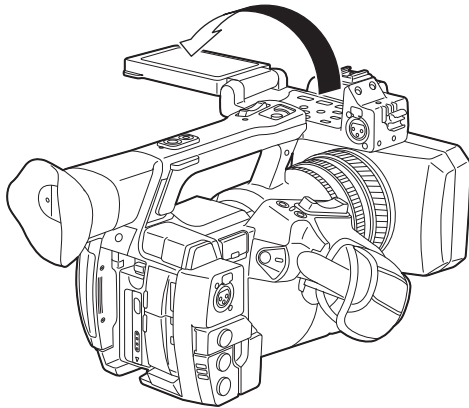

Fig. 1

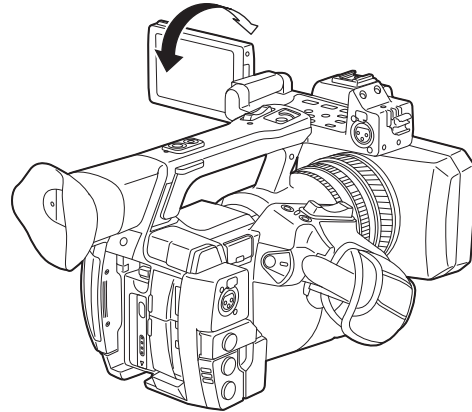

Fig. 2

#### 1 Open the LCD monitor. (Fig. 1)

The light goes on when the LCD monitor is opened. The light goes off when it is closed.

#### 2 Set the LCD monitor screen to the easiest-to-view position. (Fig. 2)

Rotates 90° toward the lens and 180° toward you.

#### NOTE

- When closing the LCD monitor, be sure to close it firmly.
- Take care not to apply excessive force on the LCD monitor when it is opened. Doing so may result in a malfunction.
- Condensation sometimes forms on the LCD panel of the LCD monitor in locations subject to extreme temperature differences. If this happens, wipe with a soft, dry cloth.
- If the camera recorder is very cold, the LCD monitor will be slightly darker than normal immediately after the power is turned on. The screen will return to its regular brightness when the temperature inside increases.
- The brightness or hue of the image on the viewfinder and LCD monitor may be different from those of the image on a TV monitor. The final check should be done on a TV monitor.

### Adjusting the LCD monitor

#### ■ Adjusting the brightness, contrast, and color level

Adjust [LCD BRIGHTNESS] (brightness), [LCD CONTRAST] (contrast), and [LCD COLOR LEVEL] (color level) in the main menu → [DISPLAY SETUP] → [LCD SETTING].

These adjustments will not affect the images to be recorded.

#### ■ Adjusting the backlight luminance

Switches the brightness of the LCD monitor backlight. There are two ways to do this:

- Set from the main menu → [DISPLAY SETUP] → [LCD SETTING] → [LCD BACKLIGHT].
- Press the <LCD BACKLIGHT> button. Each press of the button switches in the order [0] → [1] → [-3] → [-2] → [-1].

### Mirror shooting

When recording with the LCD monitor rotated towards the lens side, if the camera is set [MIRROR] in the main menu → [DISPLAY SETUP] → [SELF SHOOT], the image is displayed in reverse in left and right on the LCD monitor. This allows shooting as if looking at a mirror image. Note that only the display of the LCD monitor is horizontally reversed. Recording is performed normally.

### Highlighting the outlines of images

It is easier to focus if the outlines of images on the LCD monitor are highlighted.

Even when the outlines are highlighted on the LCD monitor, images output from the camera recorder and recorded images are not affected.

To highlight outlines, set [ON] in the main menu → [DISPLAY SETUP] → [EVF DETAIL], and adjust [EVF PEAK LEVEL] and [EVF PEAK FREQ] in the main menu → [DISPLAY SETUP].

## Adjusting and setting the viewfinder

The viewfinder of this camera is a 0.5 type organic EL. Use either the viewfinder or the LCD monitor depending on your purpose and the shooting conditions.

### Using the viewfinder

When it is difficult to use the LCD monitor because the surroundings are bright, you can check the image using the viewfinder.

Positioning your eye near the viewfinder will trigger the eye sensor to automatically display the image.

- The eye sensor sensitivity can be set to [HIGH] or [LOW] in the main menu → [DISPLAY SETUP] → [EYE SENSOR].
- The eye sensor may not work properly depending on the shape of the eyeglasses you may be wearing, how you hold the camera, or by strong light present in the vicinity of the eye piece. If this happens, switch the image display by assigning [EVF ON/OFF] to the USER button.

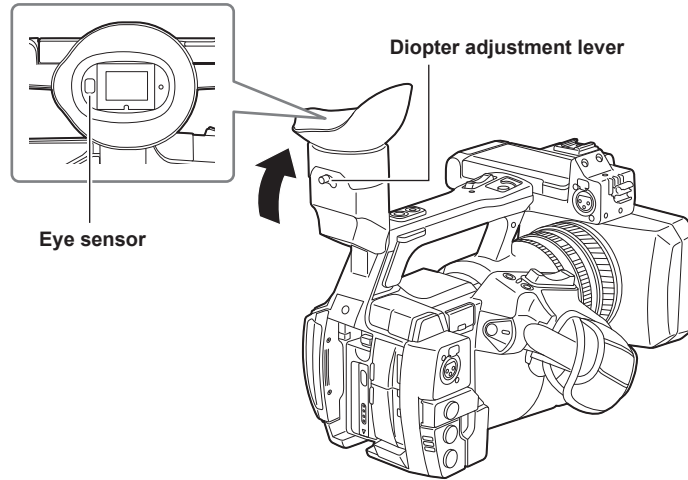

#### 1 Set the viewfinder screen to the easiest-to-view position.

The viewfinder can be lifted vertically to approximately 90 degrees.

#### 2 Adjust the characters inside the viewfinder screen so that they are clearly visible using the diopter adjustment lever.

#### NOTE

- The image brightness and color hue seen on the viewfinder and LCD monitor may be different from that seen on a TV monitor. The final check of the color hue should be done on a TV monitor.

### Adjusting the viewfinder

#### ■ Adjusting the brightness, contrast, and color level

Adjust [EVF BRIGHTNESS] (brightness), [EVF CONTRAST] (contrast), and [EVF COLOR LEVEL] (color level) in the main menu → [DISPLAY SETUP] → [EVF SETTING].

These adjustments will not affect recorded images.

#### ■ Switching between color and monochrome

The viewfinder screen can be switched between color display and monochrome display. Set from the main menu → [DISPLAY SETUP] → [EVF SETTING] → [EVF COLOR].

### Highlighting the outlines of images

It is easier to focus if the outlines of images in the viewfinder are highlighted.

Even when the outlines are highlighted on the LCD monitor, images output from the camera recorder and recorded images are not affected.

To highlight outlines, set [ON] in the main menu → [DISPLAY SETUP] → [EVF DETAIL], and adjust [EVF PEAK LEVEL] and [EVF PEAK FREQ] in the main menu → [DISPLAY SETUP].

## Tally lamp

If set to anything other than [OFF] in the main menu → [OTHER FUNCTIONS] → [TALLY LAMP], you can make up the tally lamp light while photographing.

Also, the tally lamp will flash when the following situations occur:

- When the remaining capacity of the battery is exhausted (four times per second)
- The P2 card has less free space to record and the battery level is low (one time per second)
- The P2 card has been removed while being accessed (four times per second)
- The P2 card has no more space to record (four times per second)
- When the warnings such as the fluctuation of the reference signal for the <GENLOCK IN/VIDEO OUT> terminal and a system error or recording abnormality warning are displayed (four times per second)

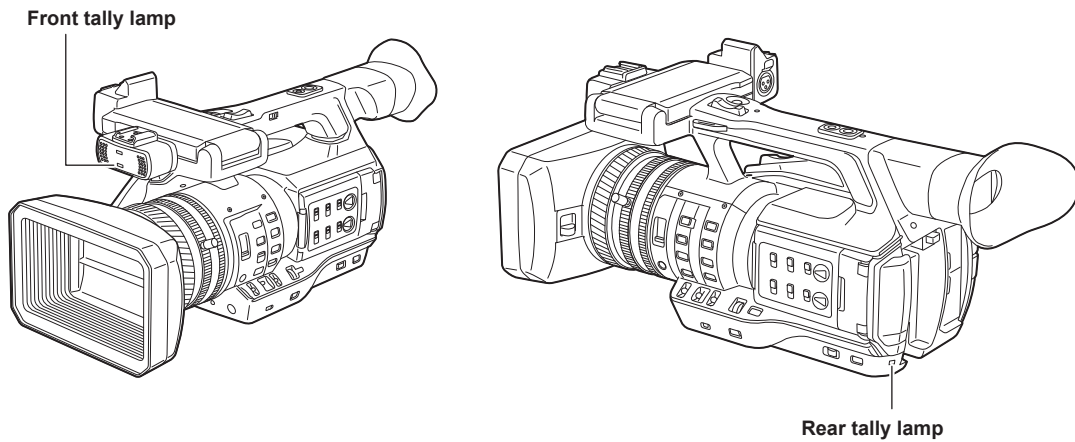

## Chapter 4 **Shooting**

---

This chapter describes the basic procedure for recording. It also describes special shooting methods such as pre-recording and loop recording.



## Basic procedures

This section describes the basic procedures for shooting. When you actually start shooting, pre-inspect your system to ensure that it works properly after making preparations.

### Preparation

- 1 Attach the fully charged battery, or connect the AC adaptor. (page 25)
- 2 Set the power switch to <ON>. (page 31)
- 3 Insert the P2 card. (page 33)
- 4 Adjust the angle of the LCD monitor and viewfinder or other conditions. (pages 39, 40)
- 5 Set the lens cover lever to <OPEN>. (page 29)

#### NOTE

- Even if the battery is fully charged, the remaining capacity of the battery may not be correctly displayed.

### Shooting

For shooting, use the following steps.

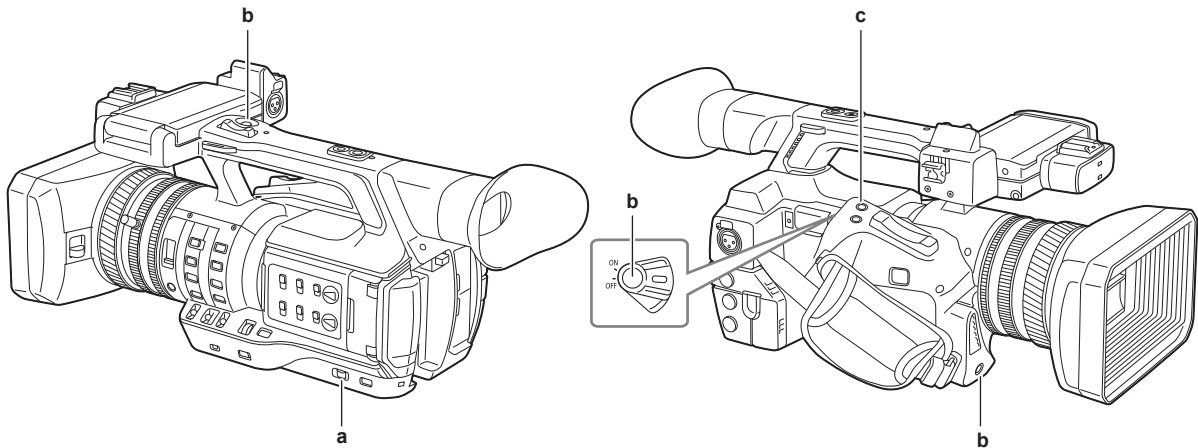

- a: <AUTO/MANUAL> switch  
 b: Recording button (grip side, handle side, front side)  
 c: <REC CHECK> button

#### 1 Set the video settings and the audio input.

Before shooting, the followings must be set or adjusted.

- Image settings for the brightness function (iris, gain, shutter) and the white balance adjustment function, etc.
- Audio input settings for audio recording.
- Adjusting audio recording level

#### 2 Select shooting mode with the <AUTO/MANUAL> switch.

<AUTO>: auto mode

- [A] is displayed at the upper part of the viewfinder and LCD monitor.
- Focus, iris, gain, shutter, and white balance are automatically adjusted.
- You can set the operation specifics for auto mode in the main menu → [AUTO SW].

<MANUAL>: manual mode

- To adjust focus, iris, gain, shutter speed, and white balance manually, set the camera to manual mode.
- Adjust the brightness by adjusting the iris and ND filter. (page 46)
- To focus manually, use the focus operation. (page 46)
- To adjust the white balance, adjust the white balance and black balance. (page 50)
- To set the audio input and adjust the recording level, switch audio input. (page 62)

#### 3 Press the REC button to start recording.

- The REC button is on three locations: the grip side, the handle side, and the front side.
- During recording, the tally lamp lights red.

#### 4 To stop recording, press the REC button again.

#### 5 Check videos recorded.

After recording ends, pressing the <REC CHECK> button automatically plays back approximately the last three seconds of the latest clip. Holding down the <REC CHECK> button for one second plays back from the last ten seconds of the latest clip. In this way, you can check whether video has been recorded properly.

- Returns to recording standby after checking.
- For clips within ten seconds, previous clips are not played back even if the <REC CHECK> button is held down after returning to the start of the current clip.

 **NOTE**

- During recording standby and recording, operation buttons (<<<<>, <>>>>, <>/||>, <■>) do not function.
- When highly bright subjects (e.g. sun or lighting) are shot, the periphery of the subject might be colored.
- When shooting at low angles, using the REC button on the handle side is helpful.
- The REC button on the handle side includes a hold mechanism to prevent accidental operation.
- The REC button on the front side can be disabled by settings. (page 135)
- In the following cases, it may take time to complete writing to the P2 card even when you have pressed the REC button to stop recording. For this reason, if you press the REC button soon to start recording, the camera is unable to operate. [REC PAUSE INVALID] is displayed in the center of the screen. After the record ending process has completed and [REC PAUSE INVALID] has disappeared, next recording can be started.
  - Stopping of short-term recording
  - Stopping immediately after recording to two microP2 memory cards

### Selecting the resolution, codec, and video format for recording

You can select the recording resolution (1080P, 1080i, 720P, 480i, 576i), recording codec (AVC-Intra, AVC-LongG, DVCPRO HD, etc.), and the recording frame rate.

Set in the main menu → [SYSTEM MODE] → [LINE&FREQ] and [REC FORMAT].

■ **Resolution: 1920×1080**

Setting			Recording format
[LINE&FREQ]	[REC FORMAT]	[CAMERA MODE]	
[1080-59.94P]	[AVC-I100/60P] [AVC-G25/60P] [AVC-G12/60P]	—	1080/60P
	[AVC-I200/30PN] [AVC-I100/30PN] [AVC-G50/30PN] [AVC-G25/30PN] [AVC-G12/30PN]	—	1080/30PN Native
	[AVC-I200/24PN] [AVC-I100/24PN] [AVC-G50/24PN] [AVC-G25/24PN] [AVC-G12/24PN]	—	1080/24PN Native
[1080-59.94i]	[AVC-I200/60i] [AVC-I100/60i] [AVC-I50/60i] [AVC-G50/60i] [AVC-G25/60i] [AVC-G12/60i] [DVCPRO HD/60i]	—	1080/60i
[1080-50P]	[AVC-I100/50P] [AVC-G25/50P] [AVC-G12/50P]	—	1080/50P
	[AVC-I200/25PN] [AVC-I100/25PN] [AVC-G50/25PN] [AVC-G25/25PN] [AVC-G12/25PN]	—	1080/25PN Native
[1080-50i]	[AVC-I200/50i] [AVC-I100/50i] [AVC-I50/50i] [AVC-G50/50i] [AVC-G25/50i] [AVC-G12/50i] [DVCPRO HD/50i]	—	1080/50i
[1080-23.98PsF]	[AVC-I200/24PN] [AVC-I100/24PN]	—	1080/24PN Native

## ■ Resolution: 1280×720

Setting			Recording format	
[LINE&FREQ]	[REC FORMAT]	[CAMERA MODE]		
[720-60P]	[AVC-I200/60P] [AVC-I100/60P] [AVC-I50/60P] [AVC-G50/60P] [AVC-G25/60P] [AVC-G12/60P]	—	720/60P	
	[DVCPRO HD/60P]			
	[AVC-I100/30PN]			720/30PN Native
	[AVC-I100/24PN]			720/24PN Native
[720-50P]	[AVC-I200/50P] [AVC-I100/50P] [AVC-I50/50P] [AVC-G50/50P] [AVC-G25/50P] [AVC-G12/50P]	—	720/50P	
	[DVCPRO HD/50P]			
	[AVC-I100/25PN]			720/25PN Native

## ■ Resolution: 720×480

Setting			Recording format
[LINE&FREQ]	[REC FORMAT]	[CAMERA MODE]	
[480-59.94i]	[DVCPRO50/60i]	[60i]	480/60i
	[DVCPRO/60i]	[30P]	480/30P over 60i 2:2 Pull Down
	[DV/60i]		

## ■ Resolution: 720×576

Setting			Recording format
[LINE&FREQ]	[REC FORMAT]	[CAMERA MODE]	
[576-50i]	[DVCPRO50/50i]	[50i]	576/50i
	[DVCPRO/50i]	[25P]	576/25P over 50i 2:2 Pull Down
	[DV/50i]		

 **NOTE**

- In 480i/576i mode, the video aspect ratio for recording and output can be changed.

## Adjustable settings when shooting

Adjust the iris and gain when shooting.

### Iris

**1** Switch to manual mode with the <AUTO/MANUAL> switch. (page 43)

**2** Press the <IRIS> button to switch the adjustment method for the lens aperture.

[AUTO IRIS]: Adjusts iris setting automatically. (Auto iris)

[MANUAL IRIS]: Adjust the lens iris manually. (Manual iris)

**3** When on manual iris, rotate the iris ring to adjust the lens iris.

When the auto iris level function for auto iris is enabled, the value of the auto iris level can be adjusted by turning the iris ring. The value is not applied to the setting in the main menu → [SCENE FILE] → [A.IRIS LEVEL EFFECT].



#### NOTE

- Auto iris does not function when the frame rate is set to [9fps] or lower in variable frame rate, and when the shutter speed is set to less than 1/12.

### Gain

If the camera recorder screen is dark, increase the gain to brighten the screen.

**1** Switch to manual mode with the <AUTO/MANUAL> switch. (page 43)

**2** Switch gain with the <GAIN> switch.

<L>: Normally set to this position. (Factory setting is 0 dB)

<M>: Increases the gain of the camera image amp. (Factory setting is 6 dB)

<H>: Increases the gain of the camera image amp. (Factory setting is 12 dB)

The gain values for <L>, <M>, and <H> can be changed in the main menu → [SW MODE] → [LOW GAIN], [MID GAIN], and [HIGH GAIN]. (page 134)

When in auto mode, selecting [ON] in the main menu → [AUTO SW] → [AGC] will set the camera to auto gain regardless of the position of the <GAIN> switch. (page 135)



#### NOTE

- When [NORMAL] is selected from the main menu → [SYSTEM MODE] → [SHOOTING MODE], the setting of -3 dB does not function.

### Super gain

When shooting in dark locations, you can set super gain regardless of whether the camera is in auto mode or manual mode.

Select [24dB], [30dB], [36dB], or [ALL] in the main menu → [SW MODE] → [SUPER GAIN].

You can switch to the selected gain by pressing a USER button assigned [SUPER GAIN]. (page 37)

When [ALL] is selected, each time the USER button is pressed, the camera toggles [24dB] → [30dB] → [36dB] → normal gain settings in order.



#### NOTE

- Super gain does not function when the frame rate is set to lower than [12fps] in variable frame rate, or when the shutter speed is set to lower than 1/12.

### Brightness adjustment

When the external light is strong, you can switch the ND filter (brightness adjustment filter) to use with the <ND FILTER> switch.

**1** Change the setting of the <ND FILTER> switch.

<1/64>: Reduce the amount of light entering the MOS sensor to 1/64.

<1/16>: Reduce the amount of light entering the MOS sensor to 1/16.

<1/4>: Reduce the amount of light entering the MOS sensor to 1/4.

<OFF>: Does not use the ND filter.

### Macro

Macro function can be switched [ON]/[OFF].

**1** Press the USER button to which [FOCUS MACRO] has been assigned.

- When [ON] is set,  is displayed at the top of the focus display on the viewfinder or LCD monitor.

- The operation mode when [ON] is set can be made in the main menu → [SW MODE] → [MACRO MODE].

- Only the wide macro area is enabled when [MACRO MODE] is set to [WIDE]. The minimum object distance (M.O.D) is maintained to be 1.1 m when the zoom position is within the tele macro area.

- Tele macro area and wide macro area are enabled when [MACRO MODE] is set to [ALL].

### Focusing (manual focus)

**1** Switch the method of controlling the focus with the <FOCUS> switch.

<A>: Changes to the auto focus mode. Adjusts the focus automatically.

<M>: Changes to the manual focus mode. Control the focus ring manually to adjust the focus.

<∞>: Changes to the manual focus mode after the focus distance is set to infinity.

This switch is the spring switch. Even when the <FOCUS> switch is pushed towards the <∞> side, the switch returns to the <M> position.

**NOTE**

- Since the auto focus control may not operate properly if there is a flicker, select a shutter speed that is appropriate to the light.
- If you set the camera to auto focus mode at times other than 60i (50i) and 60P (50P), the time required for the focus control will be slightly longer than when in normal focus mode.
- When [ON] is selected in the main menu → [AUTO SW] → [AF] and the camera is in auto mode, auto focusing is performed regardless of the position of the <FOCUS> switch.
- Auto focus does not function when the frame rate is set to [9fps] or lower in variable frame rate, and when the shutter speed is set to less than 1/12.

**Auto high-speed focusing**

Pressing the <PUSH AUTO> button performs the operation set in the main menu → [SW MODE] → [PUSH AF MODE].

**[TURBO]:** Performs high-speed focusing until the image is focused, once the button is pressed.

**[NORMAL]:** Performs automatic focusing while pressing the button.

**Manual focus assist mode**

By setting [ON] in the main menu → [SW MODE] → [MF ASSIST], you can switch from manual focus mode to manual focus assist mode.

- Compared to manual focus mode, you can adjust the focus (course adjustment) by rotating the focus ring approximately a half-turn.
- After adjusting with the focus ring, the focus is automatically adjusted (fine adjustment).
- When the focus deviation is great, it may not be in focus.
- After executing auto adjustment, it will not adjust automatically until you move the focus ring again.

**Focus assist function**

The focus assist function enables you to focus the target easily.

Expanded display in the viewfinder and LCD monitor, focus in red display (display with the contours of the image in red), and focus bar display are available.

**Expanded display [EXPAND]**

Set to [EXPAND] in the main menu → [SW MODE] → [FOCUS ASSIST MODE] beforehand.

When the <FOCUS ASSIST> button is pressed, the center of the screen is expanded approx. three times so that you can focus the image easily.

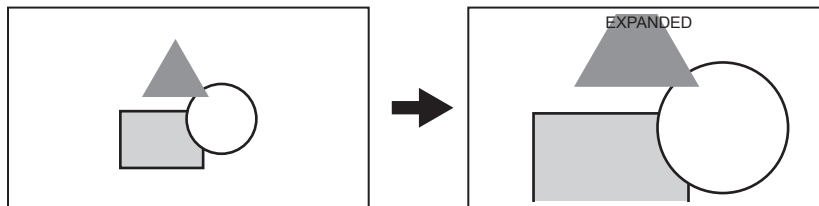

- In the expanded display, the status display and zebra pattern disappear, and [EXPANDED] is displayed at the top of the screen.

**NOTE**

- Viewfinder screen and LCD monitor screen are expanded.
- Expanded display is unavailable in the video output, SDI output, and HDMI output.
- The screen returns to the normal screen in approximately 10 seconds.

**Focus in red display [IN RED]**

Set [IN RED] in the main menu → [SW MODE] → [FOCUS ASSIST MODE] beforehand.

Press the <FOCUS ASSIST> button to put red borders around the contours of the image. When this happens the screen frame will turn red.

Adjust the focus so that the contours of the subject you want to focus on turn red.

**NOTE**

- It is displayed only on the viewfinder screen and LCD monitor screen. When various status information is displayed, they will disappear.

## Focus bar display [FOCUS BAR]

The focus bar can be displayed when [ON] is set in the main menu → [DISPLAY SETUP] → [FOCUS BAR].

The degree of focus is indicated by the length of the bar.

- White bar: Focus bar display
- Green line: Peak display

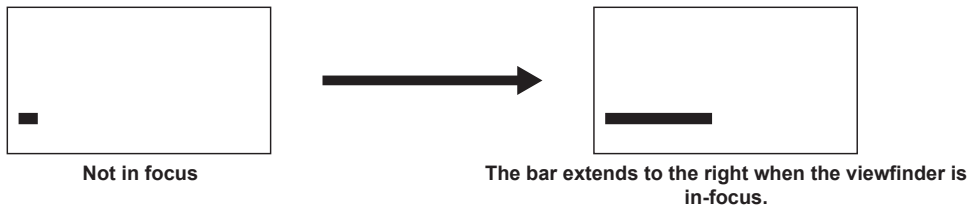

## Area mode function

You can perform the following operations by displaying the area frame with the control stick.

- Area auto focus function  
Auto focus operation is performed within the area selected with the area frame.
- Area auto iris function  
The iris value is adjusted automatically within the area selected with the area frame.
- Area brightness display  
The luminance level of the center of the selected area frame is displayed.

## Operation function settings

Set the operations to be assigned to the area mode function from the main menu.

### 1 Select the desired function in the main menu → [SW MODE] → [AREA MODE].

- [INHIBIT]: Does not assign a function.
- [FOCUS]: Area focus function and area focus bar function (When [FOCUS BAR] is set)
- [IRIS]: Area iris function
- [Y GET]: Area brightness display
- [FOCUS/IRIS]: Simultaneous operation of area focus function/area iris function, and area focus bar function (When [FOCUS BAR] is set)
- [FOCUS/Y GET]: Simultaneous operation of area focus function/area brightness display, and area focus bar function (When [FOCUS BAR] is set)

## Operation of area mode function

The function set in the main menu → [SW MODE] → [AREA MODE] can be used by performing the following operation when shooting or while in shooting standby.

### 1 Press the control stick.

- An area frame (white) is displayed.

### 2 Press the control stick upward/downward/to the left/to the right to move the area frame to a desired position.

### 3 Press the control stick.

- The area frame color changes from white to yellow.
- When the yellow frame is displayed, the function set for [AREA MODE] can be operated in the area frame.
- While the function is activated, [AREA] is displayed on the right of the display.
- When the area brightness display is activated, the brightness display in the center does not operate.

### 4 Press the control stick for two seconds or longer.

- The area frame disappears and the camera exits the area mode function.

## NOTE

- The area mode function is released when the power is turned off or when a video is played back.

## Level gauge function

A level gauge that indicates the horizontal and vertical inclinations of the camera recorder can be displayed on the LCD monitor.

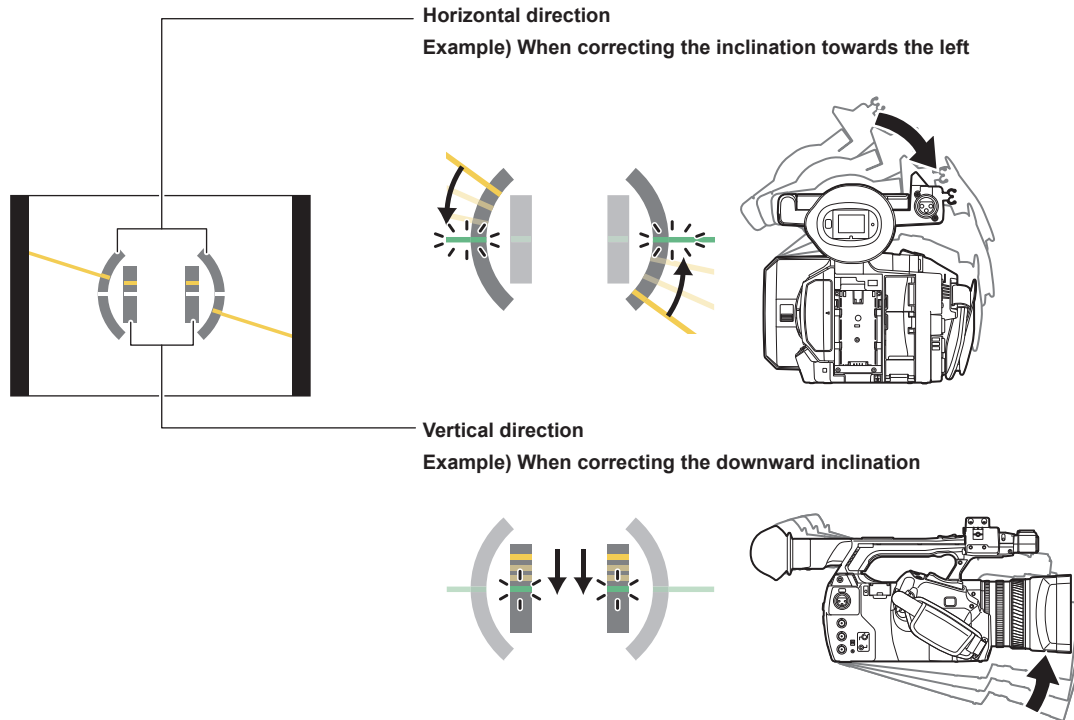

Orange lines will be displayed when inclined. Orange lines will be changed to green lines when there is almost no inclination. Inclinations will be displayed up to approximately  $\pm 45^\circ$  in the horizontal direction, and up to  $\pm 30^\circ$  in the vertical direction.

**1** Select [ON] in the main menu → [DISPLAY SETUP] → [LEVEL GAUGE].

### NOTE

- The level gauge display is not recorded.
- The level gauge is not displayed in the viewfinder.
- The level gauge is not displayed when selecting [MIRROR] in the main menu → [DISPLAY SETUP] → [SELF SHOOT].
- The level gauge is not displayed when selecting [ON] in the main menu → [SYSTEM MODE] → [SCAN REVERSE].
- While moving the camera, the level gauge may not be displayed properly.
- When shooting while tilting the camera upward or downward greatly, the level gauge may not be displayed properly.
- When pressing the USER button where [LEVEL GAUGE] is assigned in the main menu → [USER SW], [ON] and [OFF] can be switched.
- When holding down the USER button where [LEVEL GAUGE RESET] is assigned in the main menu → [USER SW], the setting will be reset to the factory setting.
- When pressing the USER button where [LEVEL GAUGE RESET] is assigned in the main menu → [USER SW].

## Adjusting the white and black balance

To obtain high-quality video at all times using the camera, the white and black balance must be adjusted according to conditions.

To obtain higher image quality, adjust in the order of AWB (white balance adjustment) → ABB (black balance adjustment) → AWB (white balance adjustment).

### NOTE

- When white or black balance is adjusted while video is disrupted by the generator lock, adjustment may not be performed correctly. Adjust white or black balance again after video has returned to normal.

## Adjusting the white balance

The white balance must be adjusted again when the lighting conditions change. Follow the steps below to adjust the white balance automatically.

### ■ When storing in <A> of the <WHITE BAL> switch

**1** Switch to manual mode with the <AUTO/MANUAL> switch. (page 43)

**2** Set the <GAIN> switch.

Normally, set this to 0 dB. If it is too dark, set the gain to an appropriate value.

**3** Set the <WHITE BAL> switch to <A>.

**4** Change the <ND FILTER> switch settings according to the light conditions.

For setting examples for the <ND FILTER> switch, refer to “Brightness adjustment” (page 46).

**5** Place the white pattern at a point where the light conditions match those for the light source for the subject, and zoom in on the white pattern so that the white color appears in the screen.

**6** Adjust the lens aperture.

Adjust the iris so that the brightness of Y GET is approx. 70%.

**7** Press the <AWB> button.

White balance is automatically adjusted.

### ■ White pattern

- A white object (cloth or wall) near the subject may also be used for the white pattern.
- Required size of white pattern is as follows.

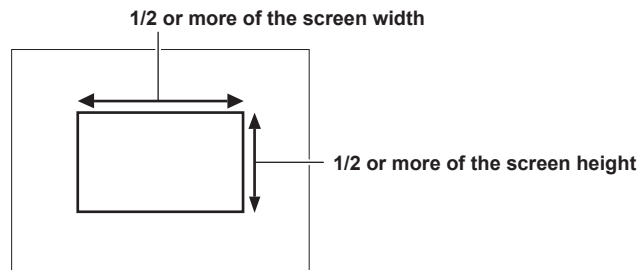

- Keep bright spotlights out of the screen.
- The white pattern must be placed at the center of the screen.

### ■ Messages displayed in the viewfinder and LCD monitor

- When the auto tracking white balance (ATW) function is operating, white balance cannot be adjusted.

Status	Message	Remark
During adjustment	[AWB Ach ACTIVE]	
Adjustment completed	[AWB A OK 3200K]	<ul style="list-style-type: none"> <li>The adjusted value is automatically stored in the specified memory (A or B).</li> </ul>
When the color temperature of the subject is lower than 2000 K or higher than 15000 K	[AWB NG COLOR TEMP LOW] [AWB NG COLOR TEMP HIGH]	<ul style="list-style-type: none"> <li>[AWB NG COLOR TEMP LOW] indicates that the temperature is lower than the displayed temperature. [AWB NG COLOR TEMP HIGH] indicates that the temperature is higher than the displayed temperature.</li> </ul>

### ■ [COLOR TEMP Ach SETTING]/[COLOR TEMP Bch SETTING] setting

- The color hue can be changed after the white balance has been adjusted automatically, after setting each item in the main menu → [SCENE FILE] → [COLOR TEMP Ach SETTING]/[COLOR TEMP Bch SETTING].
- Adjusting either one of [COLOR TEMP], [R Gain], [B Gain], and [G AXIS] changes the other three values.
- Applying white balance automatic adjustment again resets [COLOR TEMP], [R Gain], [B Gain], and [G AXIS].



### When you have no time to adjust the white balance

Set the <WHITE BAL> switch to <PRST>.

- Each time the <AWB> button is pressed, the values set in [3200K], [5600K], and main menu → [SW MODE] → [W.BAL VAR] are toggled in order. When [VAR] is selected, turning the <SEL/PUSH SET> dial button can set any white balance value between [2000K] and [15000K].
- The value displayed as [VAR] is not always assured. Use it as a reference value.
- The value for [VAR] can be viewed by pressing the <AWB> button.

### When the white balance has not been automatically adjusted

When the white balance has not been successfully adjusted, an error message is displayed on the viewfinder screen and LCD monitor displays.

Error message	Meaning	Remedy
[AWB Ach NG] or [AWB Bch NG]	The color temperature is too high, or too low.	Select the appropriate filter.
[LOW LIGHT]	There is insufficient light.	Increase the amount of light or increase gain.
[LEVEL OVER]	There is too much light.	Decrease the amount of light or decrease gain.
[COLOR TEMP LOW] or [COLOR TEMP HIGH]	The color temperature is too high, or too low.	Select the appropriate filter or light source.

### Manual setting of color temperature

The color temperature of white balance can be adjusted by the setting menu.

- 1 Press the <AWB> button to select [W.BAL VAR] mode.
- 2 Set the color temperature in the main menu → [SW MODE] → [W.BAL VAR].

This can be set from [2000K] to [15000K].

#### NOTE

- It can also be operated by the <SEL/PUSH SET> dial button. For details, refer to “Direct menu operation” (page 73).

### Viewfinder and LCD monitor screen displays relating to white balance

For details, refer to “Screen status display” (page 151).

### Setting the auto tracking white balance (ATW) function

The camera is equipped with the Auto Tracking White Balance (ATW) function that automatically tracks the white balance of images according to the lighting conditions.

The auto tracking white balance function can be assigned to each of <A>, <B>, and <PRST> of the <WHITE BAL> switch. Configure the settings in the main menu → [SW MODE] → [ATW].

Note that if the auto tracking white balance function is assigned to the USER button, the function follows the operation of the USER button.

For details, refer to “Assigning functions to the USER buttons” (page 37).

### Canceling the auto tracking white balance

Press the USER button to which auto tracking white balance function is assigned again or change the position of the <WHITE BAL> switch. Note that if the auto tracking white balance function is set to the <WHITE BAL> switch, the function cannot be canceled with the USER button.

#### NOTE

- This function does not guarantee 100% accuracy for the white balance. Note that the tracking performance relative to changes in ambient lighting and white balance performance has been given a certain degree of latitude.
- Auto tracking white balance does not function when the frame rate is set to [9fps] or lower in variable frame rate, and when the shutter speed is set to less than 1/12.

### Adjusting the black balance

Black balance must be adjusted in the following instances:

- When the camera is used for the first time
- When the camera has not been used for a long time
- When the ambient temperature has changed considerably
- When super gain is set with the USER button
- When changing the gain switch values
- When switching the items in the main menu → [SYSTEM MODE] → [REC FORMAT]

To shoot optimum video, we recommend adjusting the black balance immediately before shooting.

Before adjusting the black balance, prepare the conditions for adjusting the white balance.

- 1 Switch to manual mode with the <AUTO/MANUAL> switch. (page 43)
- 2 Set the <WHITE BAL> switch to <A> or <B>.
- 3 Press and hold the <AWB> button for approx. two seconds.

Black balance is adjusted after the white balance.

■ Messages displayed in the viewfinder and LCD monitor

Status	Message	Remark
During adjustment	[ABB ACTIVE]	
Adjustment completed	[ABB OK]	<ul style="list-style-type: none"> <li>The adjusted value is automatically stored in memory.</li> </ul>

 **NOTE**

- During black balance adjustment, the aperture is set to automatically shut out light.
- During recording, black balance cannot be adjusted.
- During the automatic black balance execution, recording to the P2 card is not performed by pressing the REC button.
- The gain switching circuit is automatically switched during black balance adjustment. Flicker or noise sometimes appears on the viewfinder screen and LCD monitor. This is not a malfunction.

**Black balance memory**

Values stored to memory are saved even if the camera is turned off.

## Using the zoom function

Adjust the angle of view you want to shoot.

The camera has a 22x optical zoom.

The zoom can be operated at the following three locations:

- Zoom lever (on the grip)
- Zoom lever (on the handle)
- Zoom ring on the lens

Select the zoom operation with the <ZOOM> switch and the HANDLE ZOOM switch.

### Setting the <ZOOM> switch

Switch the <ZOOM> switch to set the zoom operation.

<MANUAL>: You can operate the zoom ring manually to adjust the angle of view.

<SERVO>: You can use the motor-driven zoom using the zoom lever.

### Adjusting the zoom position

Adjust the zoom with the zoom lever.

<T>: Zoom in the image.

<W>: Zoom out the image.

Lightly pressing the zoom lever on the grip will operate the zoom at low speed. Pressing strongly will operate the zoom at high speed.

#### NOTE

- To operate the zoom with higher speed, press the USER button where [FAST ZOOM] is assigned in the main menu → [USER SW] to enable/disable [FAST ZOOM].
- When [FAST ZOOM] is enabled, the motorized zoom can be operated with higher speed when the zoom lever is pushed to the end. However, the zoom sound becomes louder than usual. If the sound of the motorized zoom is obtrusive, disable [FAST ZOOM].

### Using the zoom lever on the handle

You can select three shooting modes with the HANDLE ZOOM switch.

<FIX>: Zoom with the speed set in the main menu → [SW MODE] → [H.ZOOM SPEED].

<VAR>: Zoom speed changes depending on how strong the lever is pushed. (When pushed gently, the speed becomes slower, and when pushed strongly, it becomes faster.)

<OFF>: The zoom lever does not work.

### Zoom ring

Setting the <ZOOM> switch to the <MANUAL> position will allow manual zoom operation with the zoom ring.

- When the <ZOOM> switch is at the <SERVO> position, do not operate the zoom manually. Doing so may result in a malfunction.

## Adjusting image quality

The image quality of the video to be recorded can be set in the main menu → [SCENE FILE]. To change “Advanced settings”, measuring equipment such as vector scope is necessary.

### Detail function

This function thickens or weakens the outlines of images. It effectively softens or sharpens images, but in some cases, the whole image may become rough due to emphasized noise and edges. To avoid such problems, it is necessary not to add this effect on parts where emphasizing is not needed and keep the details of the parts.

#### ■ General settings

**[MASTER DTL]:** Sets the level of the detail effect of the whole part.

**[DTL CORING]:** Sets the level of signal (including noise) not to activate the detail effect.

#### ■ Advanced settings

Set in the main menu → [SCENE FILE] → [DETAIL SETTING].

**[DETAIL]:** Sets [ON]/[OFF] of the detail function.

**[V.DTL LEVEL]:** Sets the intensity of the detail level in the vertical direction.

**[H.DTL FREQ.]:** Sets the thickness of the detail level in the horizontal direction.

**[V. DTL FREQ.]:** Sets the thickness of the detail level in the vertical direction.

**[LEVEL DEPEND.]:** When the detail of luminosity signal is emphasized, details in the darker parts are compressed. Details of bright areas are also compressed more when the value set for [LEVEL DEPEND.] is larger.

**[KNEE APE LVL]:** Sets the detail level of high luminosity areas (high-brightness areas).

**[DTL GAIN(+)]:** Sets the detail level of + direction (to make brighter).

**[DTL GAIN(-)]:** Sets the detail level of – direction (to make darker).

### Skin tone function

This function makes human skin look smoother in images.

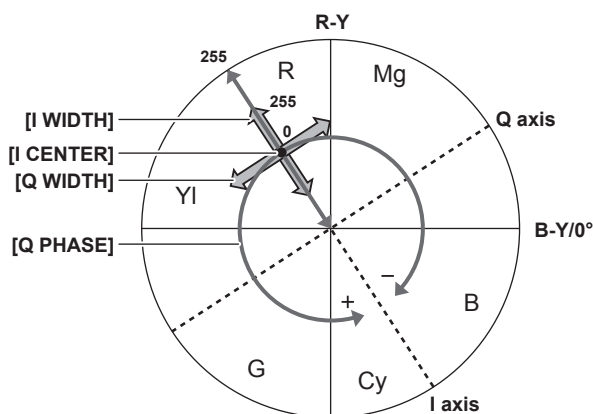

Fig. 1

#### ■ General settings

**[SKIN TONE DTL A]/[SKIN TONE DTL B]/[SKIN TONE DTL C]:** Selects what kind of skin color where the skin tone detail function should work from the three data [SKIN TONE DTL A]/[SKIN TONE DTL B]/[SKIN TONE DTL C]. [SKIN TONE DTL A]/[SKIN TONE DTL B]/[SKIN TONE DTL C] can be set alone or in combination.

**[SKIN TONE ZEBRA]:** When [SKIN TONE DTL A]/[SKIN TONE DTL B]/[SKIN TONE DTL C] are enabled, displays the zebra pattern in the selected skin color field. The zebra pattern displays the area selected in [SKIN TONE DTL SETTING].

#### ■ Advanced settings

Configure the settings in the main menu → [SCENE FILE] → [SKIN TONE DTL SETTING].

**[DETECT TABLE]:** Selects the skin color table of the object on which the skin tone table is applied.

**[SKIN TONE GET]:** Acquires the color information of [A], [B], or [C] selected in [DETECT TABLE] from the area around the center marker. By executing this menu, [I CENTER] to [Q PHASE] data are acquired automatically.

**[SKIN DTL EFFECT]:** Sets the effect level of the skin tone detail.

• The color composition of video signal (R/G/B) can be converted to color difference signal (R-Y/B-Y) as in (Fig. 1). Within those ranges, set the area on which the following skin tone is applied, using the axis across red and cyan (I axis) and the axis across green and magenta (Q axis).

**[I CENTER]:** Sets the center position on the I axis (the area where the skin tone applied).

**[I WIDTH]:** Sets the area width where the skin tone is applied, along the I axis with [I CENTER] in the center.

**[Q WIDTH]:** Sets the area width where the skin tone is applied, along the Q axis with [I CENTER] in the center.

**[Q PHASE]:** Sets the phase where the skin tone is applied, with the Q axis being the reference.

## RB gain control function

This function makes settings to add or reduce intensity of red and blue colors according to the position of the <WHITE BAL> switch. The function works when the switch is at the <PRST> position or when automatic white balance is active. It does not work when auto tracking white balance is activated.

### ■ General settings

Use the camera with the factory settings.

### ■ Advanced settings

Configure the settings in the main menu → [SCENE FILE] → [RB GAIN CONTROL SETTING].

- When the <WHITE BAL> switch is at <PRST> position
  - [R GAIN AWB PRE]: Makes settings to add or reduce intensity of red color.
  - [B GAIN AWB PRE]: Makes settings to add or reduce intensity of blue color.
- When the <WHITE BAL> switch is at <A> position
  - [R GAIN AWB A]: Makes settings to add or reduce intensity of red color.
  - [B GAIN AWB A]: Makes settings to add or reduce intensity of blue color.
- When the <WHITE BAL> switch is at <B> position
  - [R GAIN AWB B]: Makes settings to add or reduce intensity of red color.
  - [B GAIN AWB B]: Makes settings to add or reduce intensity of blue color.
- When setting the <WHITE BAL> switch to the <A> position and automatic white balance is performed
  - [AWB A GAIN OFFSET]: Sets whether to keep the values set for [R GAIN AWB A] and [B GAIN AWB A] or reset them.
- When setting the <WHITE BAL> switch to the <B> position and automatic white balance is performed
  - [AWB B GAIN OFFSET]: Sets whether to keep the values set for [R GAIN AWB B] and [B GAIN AWB B] or reset them.

## Chroma setting function

This function sets color saturation and phase. It applies effects on whole images. It cannot be set to individual color hue.

### ■ General settings

[CHROMA LEVEL]: Sets the chroma level of the  $P_R$  signal and  $P_B$  signal. When the vector scope is used, the distance from the center (no color) increases in the whole image.

[CHROMA PHASE]: Finely adjusts the chroma phase of the  $P_R$  signal and  $P_B$  signal. When the vector scope is used, the whole image rotates clockwise or counter-clockwise.

### ■ Advanced settings

No setting items are provided.

## Matrix function

This function sets the image color representation by selecting the matrix table. If the settings are changed, the representation of all the colors in the image will also be changed.

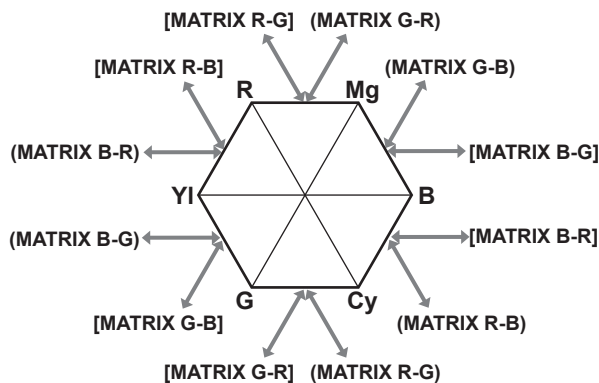

Fig. 1

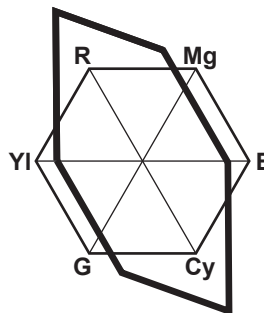

Fig. 2

### ■ General settings

[MATRIX]: Selects the matrix table to represent the color for shooting.

### ■ Advanced settings

Configure the settings in the main menu → [SCENE FILE] → [MATRIX SETTING].

It performs fine adjustment relatively on the matrix table selected in [MATRIX].

Since the fine adjustment is performed relatively, if the matrix table selected in [MATRIX] differs, the color representation may differ even when the same value is set. (Fig. 1)

Example) When adjusting [MATRIX R-G] to the + side, and [MATRIX B-G] to the - side (Fig. 2)

## Color correction function

This function sets color saturation and phase. It applies individual effect on 15 phases in a image. It can be set to individual color hue.

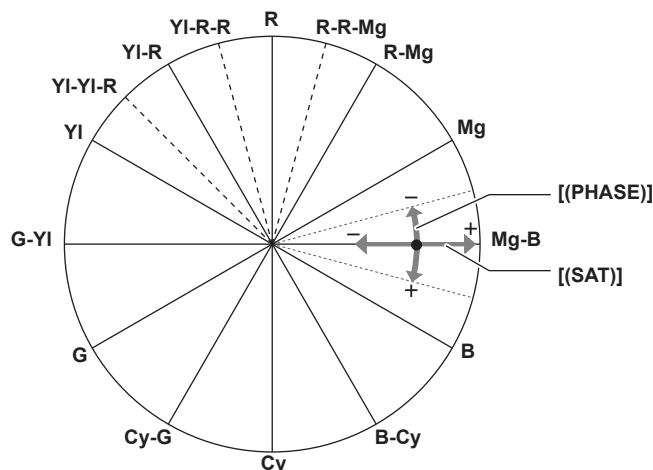

### ■ General settings

Use the camera with the factory settings.

### ■ Advanced settings

[R (PHASE)]/[R-R-Mg (PHASE)]/[R-Mg (PHASE)]/[Mg (PHASE)]/[Mg-B (PHASE)]/[B (PHASE)]/[B-Cy (PHASE)]/[Cy (PHASE)]/[Cy-G (PHASE)]/[G (PHASE)]/[G-YI (PHASE)]/[YI (PHASE)]/[YI-YI-R (PHASE)]/[YI-R (PHASE)]/[YI-R-R (PHASE)]: Changes the phases. + makes it rotate clockwise, and – makes it rotate counter-clockwise.

[R (SAT)]/[R-R-Mg (SAT)]/[R-Mg (SAT)]/[Mg (SAT)]/[Mg-B (SAT)]/[B (SAT)]/[B-Cy (SAT)]/[Cy (SAT)]/[Cy-G (SAT)]/[G (SAT)]/[G-YI (SAT)]/[YI (SAT)]/[YI-YI-R (SAT)]/[YI-R (SAT)]/[YI-R-R (SAT)]: Changes the saturation.

## Black control function

This function sets the black level that is to be the reference of luminance.

### ■ General settings

[MASTER PED]: Sets the reference black level. RGB also changes by changing this setting. – makes the black color darker, and + makes it less dark.

### ■ Advanced settings

Configure the settings in the main menu → [SCENE FILE] → [RGB BLACK CONTROL SETTING].

[R PED]: Sets the pedestal level of Rch.

[G PED]: Sets the pedestal level of Gch.

[B PED]: Sets the pedestal level of Bch.

[PEDESTAL OFFSET]: Sets whether to keep the values set for each item of [R PED], [G PED], and [B PED] or reset them when automatic black balance adjustment is performed.

## Gamma function

This function optimizes the tone of images.

### ■ General settings

[GAMMA MODE SEL]: Selects a gamma mode from seven types.

### ■ Advanced settings

Configure the settings in the main menu → [SCENE FILE] → [GAMMA SETTING].

[MASTER GAMMA]: Sets the master gamma in 0.01 steps.

• When [FILM-REC] is selected in [GAMMA MODE SEL]

[F-REC DYNAMIC LVL]: Sets dynamic range.

[F-REC BLACK STR LVL]: Sets black stretch.

• When [VIDEO-REC] is selected in [GAMMA MODE SEL]

[V-REC KNEE SLOPE]: Sets knee slope.

[V-REC KNEE POINT]: Sets knee point.

[BLACK GAMMA]: Sets the gamma curve compression and expansion of dark areas.

[B. GAMMA RANGE]: Sets the maximum level to perform compression/expansion.

## Knee function

This function sets the compression of video signals to prevent halation in images.

### ■ General settings

Use the camera with the factory settings.

### ■ Advanced settings

Configure the settings in the main menu → [SCENE FILE] → [KNEE SETTING].

**[KNEE MODE]:** Sets the operation mode of knee function ([AUTO]/[MANUAL]/[OFF]).

- When [AUTO] is selected in [KNEE SETTING]

**[A.KNEE RESPONSE]:** Sets the speed of response. Smaller values make the response faster.

- When [MANUAL] is selected in [KNEE SETTING]

**[KNEE MASTER POINT]:** Sets the knee point position in 0.5% steps.

**[KNEE MASTER SLOPE]:** Sets the knee inclination.

**[KNEE MASTER SLOPE Rch]:** Sets the knee inclination of Rch.

**[KNEE MASTER SLOPE Bch]:** Sets the knee inclination of Bch.

## High color function

This function sets the color dynamic range.

### ■ General settings

**[HI-COLOR SW]:** Turns the mode that expands the color dynamic range [ON]/[OFF].

**[HI-COLOR LVL]:** Selects the level of mode that expands the color dynamic range.

### ■ Advanced settings

Use the camera in a general settings.

## White clip function

This function sets the brightest part of video signals to be not brighter than a certain level.

### ■ General settings

Use the camera with the factory settings.

### ■ Advanced settings

Configure the settings in the main menu → [SCENE FILE] → [WHITE CLIP SETTING].

**[WHITE CLIP]:** Turns the white clip function [ON]/[OFF]. When the function is [ON], the setting value of [WHITE CLIP LVL] is enabled.

**[WHITE CLIP LVL]:** Sets the white clip level.

**[Rch CLIP LVL]:** Sets the clip level of Rch for white clips.

**[Bch CLIP LVL]:** Sets the clip level of Bch for white clips.

## Setting the electronic shutter

### Shutter mode

The shutter modes available on the electronic shutter of the camera and selectable shutter speeds are as follows.

#### Using a fixed shutter speed

- To remove flicker caused by lighting
- To shoot fast-moving subjects clearly

#### Using the synchro scan mode

- To shoot so that stripe patterns in the horizontal direction are reduced when shooting on the monitor screen
- To shoot moving subjects with special effects

### Adjusting with the <SEL/PUSH SET> dial button and <MODE/MENU CANCEL> button

The shutter mode can be switched and adjusted using the <SEL/PUSH SET> dial button and <MODE/MENU CANCEL> button.

#### Enabling shutter mode

##### 1 Press the <SEL/PUSH SET> dial button.

[SHUTTER ON] indication appears in the center of the screen. The shutter speed value is indicated and the shutter is enabled. If you press the dial button again, [SHUTTER OFF] indication appears in the center of the screen and the shutter mode is disabled. Every press of the dial button switches [SHUTTER ON]/[SHUTTER OFF].

#### Changing the shutter mode setting

##### 1 Press the <SEL/PUSH SET> dial button and enable the shutter mode.

[SHUTTER ON] indication appears in the center of the screen.

##### 2 Press the <MODE/MENU CANCEL> button and select a shutter mode.

Every press of the button switches the modes as follows, and the selected mode is highlighted in orange.

Shutter mode → variable frame rate mode → white balance variable mode

- Variable frame rate mode can be selected only when [ON] is set in the main menu → [SCENE FILE] → [VFR].
- White balance variable mode can be selected only when [VAR] is set in the main menu → [SW MODE] → [W.BAL PRESET], and the <WHITE BAL> switch is set to the <PRST> position.

##### 3 Press the <SEL/PUSH SET> dial button and select shutter mode or synchro shutter mode.

Each time the button is pressed, the normal shutter mode and synchro shutter mode will be toggled.

##### 4 Turn the <SEL/PUSH SET> dial button upward/downward and change the settings.

In synchro shutter mode, you can change the mode quickly by turning the button while it is pressed.

##### 5 Press the <MODE/MENU CANCEL> button several times until the highlight of the mode disappears.

#### NOTE

- The synchro scan display can be switched to [sec] (second) or [deg] (degree) in the main menu → [SCENE FILE] → [SYNC SCAN TYPE].
- Also, synchro scan setting can be made in the main menu → [SCENE FILE] → [SYNCHRO SCAN].
- Once selected, the shutter speed value and synchro scan speed value are saved even after the camera is turned off.
- Whichever mode the electronic shutter is used in, the higher the shutter speed, the lower the sensitivity of the camera becomes.
- When the aperture is in the automatic mode, it will increasingly open and the depth of focus will become shallower as the shutter speed is increased.
- Under lighting conditions using fluorescent lighting or other discharge tube, horizontal stripes might appear on screen. If this happens, this can be improved by adjusting the shutter speed.
- A subject that quickly crosses the camera may appear distorted when shot. This is due to the method applied for reading the signals from the pickup device (MOS sensor), and is not a malfunction.

#### Viewfinder screen display for shutter

For details, refer to “Screen status display” (page 151).



## Flash band compensation (FBC) function

The camera is equipped with a function for compensating and reducing band-like interference (called “flash band”) that occurs due to the MOS pickup device when shooting in environments where flash strobe light such as that from still cameras is present.

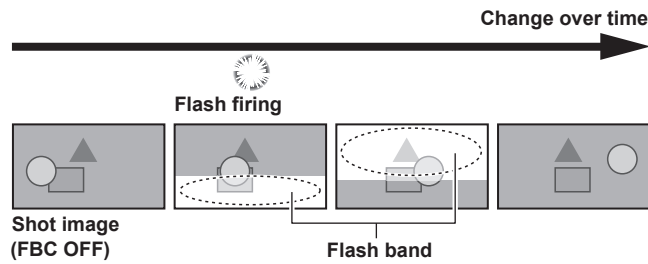

### Setting the flash band compensation function

Use after assigning the flash band compensation function to the USER button.

By pressing the USER button that is assigned with the flash band compensation function, the function turns on, and flash strobe from a still camera, etc. can be detected and compensated.

For details, refer to “Assigning functions to the USER buttons” (page 37).

When the flash band compensation function is enabled, [FBC] is displayed on the status screen.

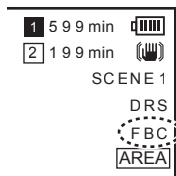

#### NOTE

- When the flash strobe lights, the following phenomena may occur. These are due to the flash band compensation function and are not malfunctions.
  - Moving subjects look as if they have been stopped for a moment.
  - The resolution drops when the flash strobe lights.
  - Horizontal lines appear in the video when the flash strobe lights.

### Using the flash band compensation function

The flash band compensation function is activated when there are large changes in brightness at the bottom of the screen regardless of whether there is flash strobe light. The flash band compensation function may be activated depending on the shooting environment such as where a bright window has zoomed in and then out. So, we recommend use of this function in shooting environments where flash strobe lighting is anticipated.

Even if flash strobe lighting occurs, sufficient flash band compensation function effect may not be obtained in some shooting environments.

### Flash band compensation function operation conditions

- The conditions the flash band compensation function can be used in are 59.94i, 59.94P, 50i, or 50P mode and when the electronic shutter, digital zoom, and variable frame rate functions are not in operation.
- Even if the flash band compensation function is enabled, the flash band compensation function is forcibly disabled if the camera is changed to a mode where the flash band compensation function cannot be used.

To use the function again, return to a mode where the function can be used, and press the USER button to turn on the flash band compensation function.

The flash band compensation function is disabled once the power is turned off.

## Variable frame rate (VFR) recording function

This camera can shoot quick motion (undercrank) or slow motion (overcrank) video in 1080P and in the AVC-I100 mode.

You can select native (PN) recording mode and standard (OVER) recording.

In native recording, quick motion and slow motion effects can be obtained without processing recorded images in nonlinear recording system. In standard recording, quick motion and slow motion effects can be obtained by processing recorded images in nonlinear recording system.

### Native variable frame rate recording

- 1 Set [1080-59.94P] ([1080-50P]) in the main menu → [SYSTEM MODE] → [LINE&FREQ].
- 2 Set either one of [AVC-I100/30PN] and [AVC-I100/24PN] ([AVC-I100/25PN]) in the main menu → [SYSTEM MODE] → [REC FORMAT].

- 3 Set [ON] in the main menu → [SCENE FILE] → [VFR].

- 4 Set the frame rate according to the shooting conditions in the main menu → [SCENE FILE] → [FRAME RATE].

[FRAME RATE] can be changed using the <SEL/PUSH SET> dial button. For details, refer to “Direct menu operation” (page 73).

- 5 Press the recording button.

Recording starts in native variable frame rate mode.

#### ■ Frame rate and effect

Quick motion (undercrank) or slow motion (overcrank) effect can be obtained by the following frame rate settings.

[SYSTEM MODE]		Shooting frame rate that can be selected		
[LINE&FREQ]	[REC FORMAT]			
[1080-59.94P]	[AVC-I100/30PN]	[1fps], [2fps], [4fps], [6fps], [9fps], [12fps], [15fps], [18fps], [20fps], [21fps], [22fps], [24fps], [25fps], [26fps], [27fps], [28fps]	[30fps]	[32fps], [34fps], [36fps], [40fps], [44fps], [48fps], [54fps], [60fps]
	[AVC-I100/24PN]	[1fps], [2fps], [4fps], [6fps], [9fps], [12fps], [15fps], [18fps], [20fps], [21fps], [22fps]	[24fps]	[25fps], [26fps], [27fps], [28fps], [30fps], [32fps], [34fps], [36fps], [40fps], [44fps], [48fps], [54fps], [60fps]
[1080-50P]	[AVC-I100/25PN]	[1fps], [2fps], [4fps], [6fps], [9fps], [12fps], [15fps], [18fps], [20fps], [21fps], [22fps], [23fps], [24fps]	[25fps]	[26fps], [27fps], [28fps], [30fps], [32fps], [34fps], [37fps], [42fps], [45fps], [48fps], [50fps]
Effect on playback		Quick motion (Quicker in smaller value)	Standard	Slow motion (Slower in smaller value)
Audio recording		Not available	Available	Not available

#### NOTE

- During native variable frame rate recording, pre-recording, loop recording, interval recording, one-shot recording, dual codec recording, and one-clip recording can not be performed.
- Audio cannot be recorded. At this time, no audio is output and A.REC is displayed over the audio level meter. When the recording starts, [VFR ON, NO AUDIO RECORDING] is displayed.
- Time code is fixed to recording run.
- The screen may be distorted when changing the frame rate setting.
- Auto iris and auto focus do not function when the frame rate is set to [9fps] or lower, and when the shutter speed is set to less than 1/12. They must be operated manually.
- When the frame rate is set to [9fps] or lower, the shutter setting is forcibly disabled and shutter speed settings cannot be changed.
- Audio can be recorded when the recording format is [AVC-I100/24PN] and the frame rate is [24fps], and when the recording format is [AVC-I100/30PN] ([AVC-I100/25PN]) and the frame rate is [30fps] ([25fps]). In this case, the time code can be set to free run. When the frame rate is set to lower than [12fps], the shutter speed is forcibly set to the same time value as the frame rate. Shutter speed setting cannot be changed.

### Standard variable frame rate recording (pull-down recording)

- 1 Set [1080-59.94P] ([1080-50P]) in the main menu → [SYSTEM MODE] → [LINE&FREQ].

- 2 Set [AVC-I100/60P] or [AVC-I100/50P] in the main menu → [SYSTEM MODE] → [REC FORMAT].

- 3 Set [ON] in the main menu → [SCENE FILE] → [VFR].

- 4 Set the frame rate according to the shooting conditions in the main menu → [SCENE FILE] → [FRAME RATE].

[FRAME RATE] can be changed using the <SEL/PUSH SET> dial button. For details, refer to “Direct menu operation” (page 73).

- 5 Press the recording button.

Recording starts in standard variable frame rate.

 **NOTE**

- During standard variable frame rate recording, pre-recording, loop recording, interval recording, one-shot recording, dual codec recording, and one-clip recording can not be performed.
- Audio can be recorded.
- Auto iris, auto focus, and auto tracking white balance do not function when the frame rate is set to [9fps] or lower, or when the shutter speed is set to lower than 1/12. They must be operated manually.

## Selecting audio input and adjusting recording levels

The camera supports independent 4-channel sound recording in all recording formats (HD, SD).

You can switch audio input recorded on the various channels between the built-in microphone, an external microphone, or a connected audio device.

### Selecting audio input signals

Select the audio signal to be recorded to audio channel 1/2.

Audio channel 3/4 is automatically determined by the <CH1 SELECT> and <CH2 SELECT> settings.

<CH1 SELECT> switch	Subjects recorded on channel 1	Subjects recorded on channel 3
<INT(L)>	L audio of built-in microphone	Microphone and device connected to <AUDIO INPUT 1>
<INPUT1>	Microphone and device connected to <AUDIO INPUT 1>	L audio of built-in microphone
<INPUT2>	Microphone and device connected to <AUDIO INPUT 2>	L audio of built-in microphone
<CH2 SELECT> switch	Subjects recorded on channel 2	Subjects recorded on channel 4
<INT(R)>	R audio of built-in microphone	Microphone and device connected to <AUDIO INPUT 2>
<INPUT1>	Microphone and device connected to <AUDIO INPUT 1>	R audio of built-in microphone
<INPUT2>	Microphone and device connected to <AUDIO INPUT 2>	R audio of built-in microphone

You can set the number of audio bits recorded in accordance with the format.

For details, refer to “System modes and recording functions” (page 74).

Format	Number of audio bits
[AVC-I100] [AVC-I50]	You can select [24BIT] and [16BIT]. You can select the main menu → [SYSTEM MODE] → [AUDIO SMPL RES].
[AVC-I200] [AVC-G50] [AVC-G25]	[24BIT] fixed.
[AVC-G12] [DVCPRO HD] [DVCPRO50] [DVCPRO] [DV]	[16BIT] fixed.

### Using the built-in microphone

#### 1 Set the <CH1 SELECT> switch to the <INT(L)> position.

The L audio signal of the built-in microphone is recorded on audio channel 1.

#### 2 Set the <CH2 SELECT> switch to the <INT(R)> position.

The R audio signal of the built-in microphone is recorded on audio channel 2.

#### NOTE

- You can switch among [STEREO], [MONO], and [OFF] of the built-in microphone in the main menu → [AUDIO SETUP] → [INPUT SETTING] → [INT MIC].
- To decrease wind noise in the microphone, set [ON] in the main menu → [AUDIO SETUP] → [RECORDING CH SETTING] → [MIC LOWCUT CH1] to [MIC LOWCUT CH4].

### Using the external microphone and audio device

#### 1 Connect the external microphone or audio device to the <AUDIO INPUT 1>/<AUDIO INPUT 2> terminal.

#### 2 Switch the connected audio input with the <INPUT 1>/<INPUT 2> switch.

Setting	Description	Input level
<LINE>	Use this setting when connected to an audio device.	You can select [+4dB] and [0dB]. You can select the main menu → [AUDIO SETUP] → [INPUT SETTING] → [INPUT1 LINE LEVEL]/[INPUT2 LINE LEVEL]. The factory setting is [0dB].
<MIC>	Use this setting when connected to a dynamic microphone.	You can select [-40dB], [-50dB], and [-60dB]. You can select the main menu → [AUDIO SETUP] → [INPUT SETTING] → [INPUT1 MIC LEVEL]/[INPUT2 MIC LEVEL]. The factory setting is [-50dB].
<+48V>	Use this setting when connected to a microphone (phantom microphone) that requires a +48V power source.	You can select [-40dB], [-50dB], and [-60dB]. You can select the main menu → [AUDIO SETUP] → [INPUT SETTING] → [INPUT1 MIC LEVEL]/[INPUT2 MIC LEVEL]. The factory setting is [-50dB].

**NOTE**

- Set the input level to [-50dB] when using AG-MC200G (optional).

**Adjusting the recording level**

The adjustment dial on the camera has manual adjustment and auto adjustment.

**Automatic adjustment****■ Setting audio channels 1/2****1 Set the <CH1>/<CH2> switch to <AUTO>.**

When set, the camera moves to auto adjustment mode and the audio recording level is automatically set in accordance with the input level.

- You can set audio channels 1/2 separately using the switch.
- When set to <AUTO>, the following operations are disabled.
  - Changing the recording level with the <AUDIO LEVEL CH1>/<AUDIO LEVEL CH2> dial.
  - Setting in the main menu → [AUDIO SETUP] → [RECORDING CH SETTING] → [LIMITER CH1]/[LIMITER CH2].

**■ Setting audio channels 3/4****1 Set [ON] in the main menu → [AUDIO SETUP] → [RECORDING CH SETTING] → [AUTO LEVEL CH3]/[AUTO LEVEL CH4].**

The camera moves to auto adjustment mode and the audio recording level is automatically set in accordance with the input level.

- You can set audio channels 3/4 separately with the switch.
- When set to <AUTO>, the following operations are disabled.
  - Recording level settings in the main menu → [AUDIO SETUP] → [RECORDING CH SETTING] → [LEVEL CONTROL CH3]/[LEVEL CONTROL CH4]
  - Setting in the main menu → [AUDIO SETUP] → [RECORDING CH SETTING] → [LIMITER CH3]/[LIMITER CH4].
- Recording level of audio signal is adjusted automatically. Therefore, depending on the ambient sound, the zoom sound may be recorded during high-speed zoom operation. In this case, adjust the recording level manually.

**Manual adjustment****■ Setting audio channels 1/2****1 Set the <CH1>/<CH2> switch to <MANU>.****2 Adjust with the <AUDIO LEVEL CH1>/<AUDIO LEVEL CH2> dial.**

If the audio meter indication exceeds 0 dB, the vertical red line of 0 dB thickens to indicate that the input audio volume is excessive. Adjust to keep lower than 0 dB.

**■ Setting audio channels 3/4****1 Set [OFF] in the main menu → [AUDIO SETUP] → [RECORDING CH SETTING] → [AUTO LEVEL CH3]/[AUTO LEVEL CH4].****2 Set and adjust in the main menu → [AUDIO SETUP] → [RECORDING CH SETTING] → [LEVEL CONTROL CH3]/[LEVEL CONTROL CH4].**

The higher the value, the higher the level.  
The factory setting is [70].

**■ Recording standard level**

You can select [12dB]/[18dB]/[20dB] in the main menu → [AUDIO SETUP] → [RECORDING CH SETTING] → [HEADROOM].

Common settings for channels 1 through 4.

**[20dB]:** Select to match to the Panasonic AJ series camera recorder for broadcasting.

**[12dB]:** Select to match to the Panasonic AG-HPX170 series camera recorder for business use.

**Adjustment with the <F.AUDIO LEVEL> dial**

Adjust not to reach the excessive input while watching the level meter on the LCD monitor or viewfinder screen.

- Select the audio channel you want to adjust beforehand in the main menu → [AUDIO SETUP] → [RECORDING CH SETTING] → [FRONT VR SELECT].
- Adjust with the <F.AUDIO LEVEL> dial.

**Displaying the audio level detailed**

Press the <DISP/MODE CHK> switch towards the <CHK> side to check the display on the audio screen of the mode check screen. For details, refer to "Mode check display" (page 157).

## Getting position information using the GPS

---

The GPS is built-in the camera. You can record the position information using GPS to clips as clip metadata.

Information from GPS (latitude, longitude, altitude, date and time) can be viewed on the screen. For details, refer to “Mode check display” (page 157).

Set [ON] in the main menu → [OTHER FUNCTIONS] → [GPS].

- [GPS] illuminates on the LCD monitor and viewfinder screen, and GPS signal reception is indicated by bars in four levels.
- If [HOLD] is set in the main menu → [OTHER FUNCTIONS] → [P.OFF GPS DATA], the GPS position information can be retained.

### NOTE

- If it cannot position even after waiting several minutes, it means that the GPS signals are weak and difficult to receive.
- Position in the open space with a clear view of the sky.
- Detecting altitude may take more time than detecting latitude and longitude.
- When the main menu → [SYSTEM MODE] → [REC FORMAT] is set to DVCPROHD, DVCPRO50, DVCPRO, or DV mode, GPS information is not recorded to clips.
- The followings are locations where the signals from the GPS satellite cannot be properly received. Thus, you may not be able to position or you have large margin of errors.
  - Indoors
  - Near buildings or a canyon of buildings
  - In underground shopping areas
  - In forests
  - While moving in trains or automobiles
  - Inside tunnels

## Special recording functions

You can use special recording functions such as pre-recording and loop recording by setting the menu.

### Pre-recording

This function enables recording of video and audio from a fixed amount of time (approx. 3 seconds during HD recording, and approx. 7 seconds during SD recording) before recording is actually started.

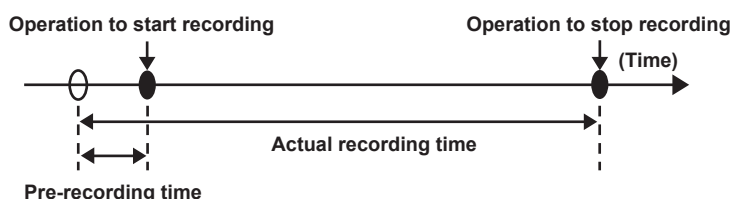

#### 1 Check the settings of each item in the main menu → [SYSTEM MODE].

For details on system modes in which the pre-recording function can be used, refer to the table in “System modes and recording functions” (page 74).

For details on menu operations, refer to “Setting menu basic operations” (page 124).

#### 2 Set [ON] in the main menu → [RECORDING SETUP] → [PRE REC].

#### 3 Press the REC button.

- [P-REC] is displayed while recording, and [P-] is displayed while paused. (page 154)

#### NOTE

- [P-REC] indication when [PRE REC] is set to [OFF]  
When [PRE REC] is set to [OFF], [REC] is displayed until recording of video or audio to the P2 card is completely finished after recording is stopped. Refer to “One clip recording mode status display” (page 154) for information about the [P-REC] indicator.
- Press the USER button to which [PRE REC] is assigned to simply toggle between [ON]/[OFF] of [PRE REC]. For details, refer to “Assigning functions to the USER buttons” (page 37).
- Video and audio according to the preset time sometimes cannot be recorded in the following cases:
  - Immediately after the power is turned on
  - After recording-related settings have been altered in the setting menu
  - Immediately after the P2 card is inserted
  - After playback or recording check is performed
- The pre-recording function does not function in the following cases:
  - When an item other than [NORMAL] is selected in the main menu → [RECORDING SETUP] → [RECORDING]

### Interval recording

The camera will record one frame at each set time interval.

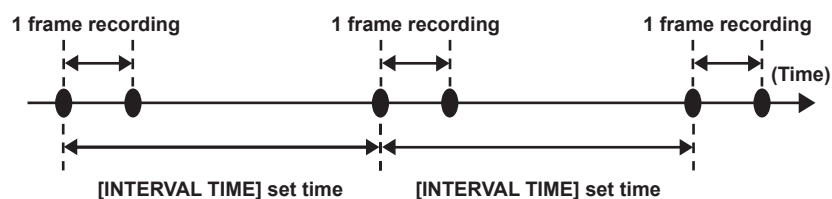

#### 1 Set all items in the main menu → [SYSTEM MODE].

#### 2 Set [INTERVAL] in the main menu → [RECORDING SETUP] → [RECORDING].

#### 3 Set the time in the main menu → [RECORDING SETUP] → [RECORDING SETTING] → [INTERVAL TIME].

#### 4 Press the REC button.

- The camera will repeat the operation of one frame recording at each set time interval.
- To stop recording, press the <■> button.
- To clear settings, set [NORMAL] in the main menu → [RECORDING SETUP] → [RECORDING].
- When [OFF] is set in the main menu → [RECORDING SETUP] → [RECORDING SETTING] → [RECORDING HOLD], interval recording settings are cleared by turning off the camera.
- [I-REC] is displayed while recording, and [I-] is displayed while paused. However, if the setting in step 3 is less than two seconds, [I-REC] flashes according to the set interval time.
- When recording is stopped, [I-] flashes.

#### NOTE

- Pre-recording and one-clip recording will not operate.
- Audio is not recorded.
- Recorded data (data recorded until the camera was stopped) is included in one file.

## One-shot recording

Recording takes place once for the set amount of time.

- 1** Set all items in the main menu → [SYSTEM MODE].
- 2** Select [ONE SHOT] in the main menu → [RECORDING SETUP] → [RECORDING].
- 3** Set the time with [ONE SHOT TIME] in the main menu → [RECORDING SETUP] → [RECORDING SETTING].
- 4** Press the REC button.
  - Once recording has taken place for the set amount of time, recording will pause.
  - To stop recording, press the <■> button.
  - To clear settings, set [NORMAL] in the main menu → [RECORDING SETUP] → [RECORDING].
  - When [OFF] is set in the main menu → [RECORDING SETUP] → [RECORDING SETTING] → [RECORDING HOLD], one-shot recording settings are cleared by turning off the camera.
  - [L-REC] is displayed while recording, and [L-] is displayed while paused.
  - When recording is stopped, [L-] flashes.

### NOTE

- While in operation, other operations are unavailable.
- Pre-recording and one-clip recording will not operate.
- Audio is not recorded.
- Recorded data (data recorded until the camera was stopped) is included in one file.
- When one-shot recording is continuously performed, the recording operation may be slower.

## Loop recording

- This function successively records to two microP2 memory cards inserted in the microP2 card slots. You cannot combine microP2 cards and P2 cards.
- When there is no more free space on the card, recording returns to the first card, and recording is continued while erasing existing data already saved on that card.

For details, refer to “Dividing clips recorded on P2 cards” (page 35).

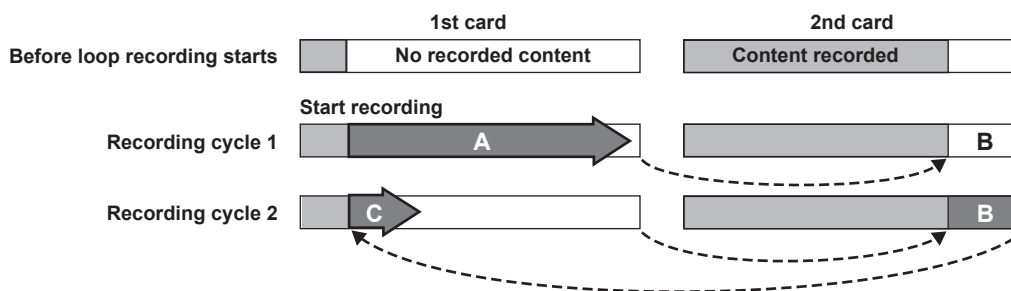

- 1** Check the settings of each item in the main menu → [SYSTEM MODE].

For details on system modes in which the loop recording function can be used, refer to the table in “System modes and recording functions” (page 74).

For details on menu operations, refer to “Setting menu basic operations” (page 124).

- 2** Set [LOOP] in the main menu → [RECORDING SETUP] → [RECORDING].

- 3** Press the REC button.

- Recording is started.
- To stop recording, press the REC button again.
- To clear settings, set [NORMAL] in the main menu → [RECORDING SETUP] → [RECORDING].
- When [OFF] is set in the main menu → [RECORDING SETUP] → [RECORDING SETTING] → [RECORDING HOLD], loop recording settings are cleared by turning off the camera.
- [L-REC] is displayed while recording, and [L-] is displayed while paused. When loop recording cannot be performed due to memory shortage, etc., [LOOP] flashes.

### NOTE

- When this function is used, use two microP2 memory cards with at least one minute of free space each.
- The remaining time of the microP2 memory card displayed in the mode check screen displays the standard recording time in accordance with the recording format. When loop recording is stopped immediately after an old recording is erased, the time recorded on the card is sometimes less than the indicated time.
- Pre-recording and one-clip recording will not operate.
- It may take time for recording to stop. The subsequent operation is not accepted until LED of microP2 memory card access stops blinking and stays lighted on.
- During loop recording, all LEDs of microP2 memory card access on the microP2 memory cards used for recording are lighted or blink orange. Loop recording stops when these microP2 memory cards are removed. Be careful.
- Loop recording may stop when the input reference signal of the generator lock is disrupted during loop recording.



## One-clip recording

You can record a single recording (from start to stop of recording) not as one clip but as a clip integrating several recordings.

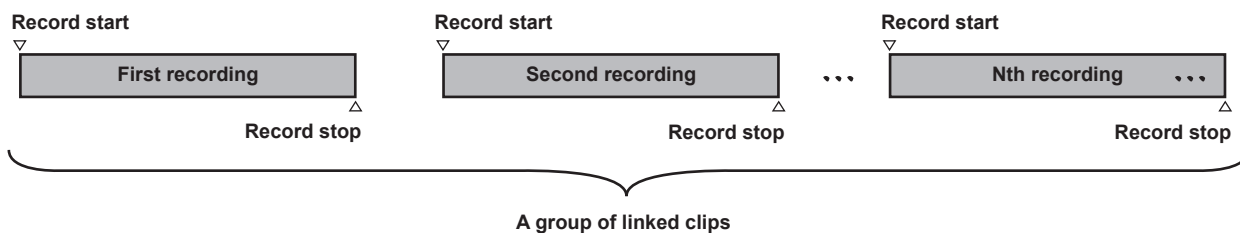

\* A maximum of 99 recordings can be linked. When the 99th recording is finished, linking of clips ends automatically and the next recording will be a new clip.

### 1 Set [ON] in the main menu → [RECORDING SETUP] → [ONE CLIP REC].

When one-clip recording mode is selected, [1-CLIP] is displayed.

### 2 Press the REC button.

The first recording starts and [START 1\*CLIP] is displayed.

Thereafter, each time recording takes place the clips are automatically linked, making a single group up to a maximum of 99 recordings.

## Recording as a new clip

When you want to split the clip as a new clip, finish linking clips using one of the following operations.

- Press and hold the <■> button for approximately two seconds while recording is paused. (When operating while recording is paused)
- Press and hold the REC button for approximately two seconds during recording, to end recording. (When operating while recording.)

By these operations, clip linking ends and [END 1-CLIP] is displayed. A new separate clip will start at the next recording.

### NOTE

- In the following cases, the camera finishes clip linking and records as a new clip.
  - When the power is turned off
  - When a P2 card recorded immediately before is removed
  - When the P2 card is formatted or the clips are deleted (when the original linked clip no longer exists)
- When the menu and thumbnails are displayed, clip linking cannot be ended even if you press and hold the <■> button for approximately two seconds or longer.

## Ending one-clip recording mode

Set [OFF] in the main menu → [RECORDING SETUP] → [ONE CLIP REC].

## Cueing up linked parts of clips

Each time recording starts, a text memo is automatically added to the recording start position so that you can cue up when playing back. You can also check the thumbnail of its position.

To automatically add a text memo to the recording start point, set [ON] in the main menu → [RECORDING SETUP] → [START TEXT MEMO].

To view or play back the point of the added text memo, select [TEXT MEMO CLIPS] in the main menu → [CLIP] → [REPOSITION] and place the cursor on the target clip.

For details, refer to “Playing back from the text memo position” (page 112).

To cue up the text memo position when playing back, set [CLIP&TEXT MEMO] in the main menu → [OTHER FUNCTIONS] → [SEEK POS SEL] and press <◀◀>/<▶▶> while playback is paused.

## Proxy recording in one-clip recording mode

You can carry out proxy recording in one-clip recording mode.

The group proxy data also can be combined as the same type of linked clip so that you can handle it as a single clip with the P2 Viewer Plus, etc.

However, when recording proxy data on an SD memory card, be careful of the following points.

- When you remove the SD memory card and replace it while continuously making clip links, proxy recording will not take place on the SD memory card until the subsequent clips are linked. Use after making sure that there is sufficient available space and number of files (maximum of 1000 clips can be recorded).
- When continuing proxy recording after replacing the SD memory card part-way through, carry out the following operation.
  - Press the <■> button for approximately two seconds to finish linking, and start recording as a new clip.
- The proxy data on the SD memory card that was discontinued during recording is not recognized as proxy data for the clip recorded on the P2 card and will remain incomplete.

## When using one-clip recording mode

- When interval recording, one-shot recording, loop recording, and variable frame rate recording functions are selected, it will not operate.
- While continuing clip linking, menu and thumbnail operations are subject to the following restrictions. They can be operated after pressing the <■> button continuously for approximately two seconds and ending clip linking.
  - You cannot change the following menu items.
    - [LINE&FREQ], [REC FORMAT], [CAMERA MODE], [AUDIO SMPL RES], [ASPECT CONV], [SCAN REVERSE]
  - You can change the variable frame rate recording function to [ON] in the main menu → [SCENE FILE] → [VFR], even while continuously linking clips. In this case, clip linking ends and subsequent recordings become separate clips each time.

- When reading/exporting to the SD memory card and reading setting files, the following menu items cannot be executed.  
Main menu → [SCENE FILE] → [LOAD/SAVE/INITIALIZE]  
All items in the main menu → [CARD FUNCTIONS]  
Main menu → [OTHER FUNCTIONS] → [USER FILE]  
Main menu → [OTHER FUNCTIONS] → [USER FILE] → [INITIALIZE]  
Main menu → [OTHER FUNCTIONS] → [MENU INITIALIZE]
- The following thumbnail items cannot be selected and operated.  
Main menu → [CLIP] → [COPY]
- In order to make it possible to link clips in the next recording, the processing time required to end recording may take slightly longer than standard recording.
- When playing back, fade processing of unlinked audio will not be done at the time recordings are linked within clips.
- When editing a clip with a large number of links using nonlinear editing software, etc., the software may not operate properly depending on the type of software.
- Refer to the support desk at the following website for the latest information on software whose operability has been confirmed.  
<http://pro-av.panasonic.net/>

## Simultaneous recording

This function records the same image onto two microP2 memory cards when the two microP2 memory cards are inserted into two slots.

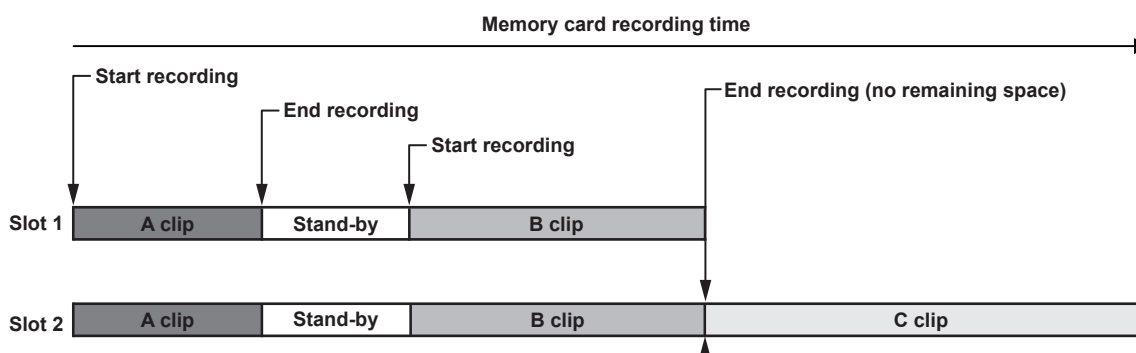

Selecting [ON] in the main menu → [RECORDING SETUP] → [SIMUL REC] will set the camera to simultaneous recording mode.

The remaining time that can be simultaneously recorded (the remaining time of the memory card that has less available recording space) is displayed in the media remaining space indicator on the screen, and [SIMUL] is displayed.

When the microP2 memory card in the slot with less remaining recording space becomes full, simultaneous recording will stop.

When starting simultaneous recording again, replace the microP2 memory card in a slot with full capacity with a new microP2 memory card, and press the REC button. When the simultaneous recording cannot be performed, [SIMUL] indication is displayed with a diagonal line.

If you press the REC button without replacing the microP2 memory card, normal recording will be performed on the microP2 memory card in slot 2 (the slot with remaining memory space).

For details on system modes in which simultaneous recording can be used, refer to the table in “System modes and recording functions” (page 74).

### NOTE

- Start recording when two microP2 memory cards are recognized. When recording is started before both microP2 memory cards are recognized, normal recording is performed using either microP2 memory card. The card status is checked after recording ends. At that time, if both cards are recognized, simultaneous recording is performed.
- When the main menu → [SYSTEM MODE] → [LINE&FREQ] is set to [1080-59.94P], [1080-50P], or [1080-23.98PsF], and [REC FORMAT] is set to [AVC-I200], simultaneous recording is not performed.
- Simultaneous recording cannot be used together with loop recording, interval recording, one-shot recording, or dual codec recording.
- If recording stops because a recording malfunction occurs in one of the microP2 memory cards during simultaneous recording, the camera will continue recording onto the other microP2 memory card. However, if the card is removed while accessing, recording will stop.
- If there is space in one of the microP2 memory cards after simultaneous recording has ended, the microP2 memory card with space will automatically be the recording target.  
Press the REC button again to record normally.
- If only one microP2 memory card is inserted when simultaneous recording mode is set, the camera will record normally.
- The final clip delete function after simultaneous recording is disabled.

## Background recording

If microP2 cards are inserted in two slots, set the background recording mode and then press the recording button to start recording simultaneously on slot 1 and 2. On slot 1, recording can be repeatedly started and stopped as necessary by operating the recording button. On slot 2, the recording operation continues as background recording.

By performing background recording on slot 2, you will not miss important scenes while recording is stopped.

For details on system modes in which background recording can be used, refer to the table in “System modes and recording functions” (page 74).

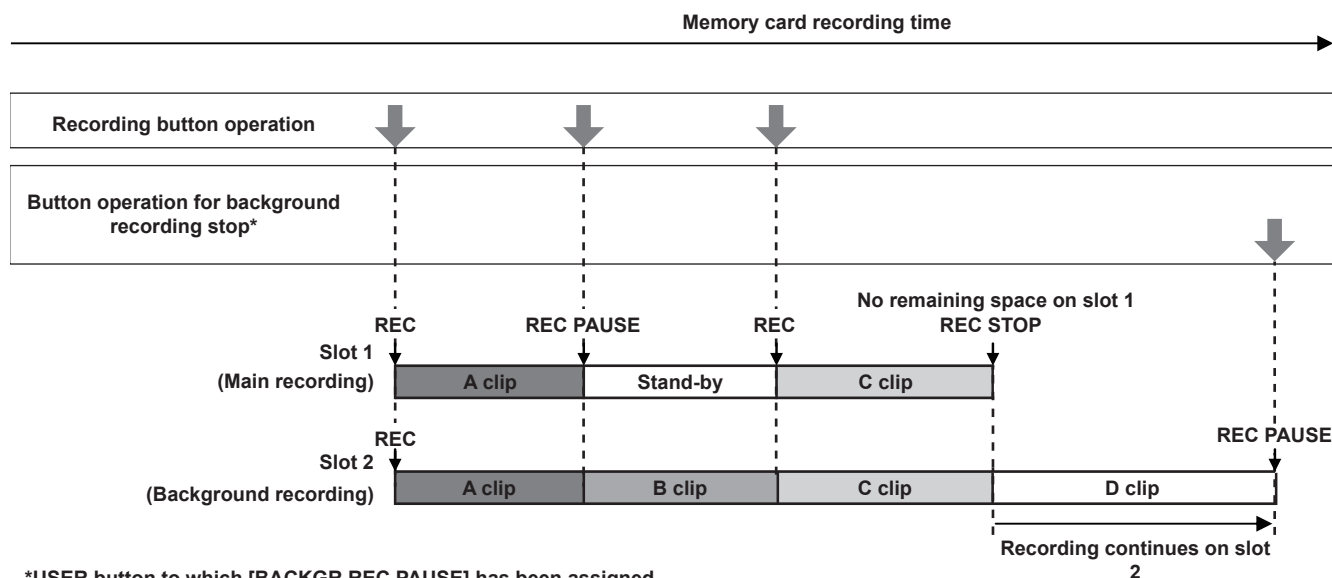

### To start background recording

#### 1 Select [ON] in the main menu → [RECORDING SETUP] → [BACKGROUND REC].

The camera goes into the background recording mode.

#### 2 Press the recording button.

Recording starts on slot 1 and 2 simultaneously, and [BACKGR] is displayed on the screen.

Recording on slot 1 can be started or stopped by recording button operations.

On slot 2, the recording operation continues as background recording.

#### NOTE

- Recording on both slot 1 and 2 are performed in the format set in the main menu → [SYSTEM MODE].
- Background recording cannot be performed in the following cases.
  - When other than [NORMAL] is set in the main menu → [RECORDING SETUP] → [RECORDING]
  - When [P2] is set in the main menu → [RECORDING SETUP] → [REC MEDIA]
  - When other than [OFF] is set in the main menu → [RECORDING SETUP] → [DUAL CODEC SETTING]
- When [4G/LTE] is set in the main menu → [NETWORK SETUP] → [NETWORK SEL], normal recording can be performed on slot 1.
- The lighting status of tally lamp changes according to starting or stopping of recording on slot 1.
- Time code is fixed to free run.
- The settings in the main menu → [OUTPUT SEL] → [HD SDI REMOTE] is disabled. Controlling of recording operation of external devices (such as a recorder) cannot be performed.
- In background recording mode, deleting last clip function is disabled.
- Even while background recording is performed on slot 2, if recording on slot 1 is being stopped, microP2 memory card in slot 1 can be replaced.
- If a recordable microP2 memory card is not inserted in slot 2 or the free space of the microP2 memory card in slot 2 has run out, normal recording can be performed on slot 1.

### To end background recording

#### 1 Hold down the USER button to which [BACKGR REC PAUSE] has been assigned for approx. five seconds.

The background recording on slot 2 will be stopped. The [BACKGR] indication is displayed with a diagonal line.

#### NOTE

- While recording is performed on slot 1, the background recording on slot 2 cannot be ended. End the background recording while recording is stopped on slot 1.
- The background recording on slot 2 ends in the following cases.
  - When the power is turned off
  - When the free space of the microP2 memory card has run out
  - When an error has occurred on writing to the microP2 memory card
  - When the USER button to which [BACKGR REC PAUSE] has been assigned is held down for approx. five seconds

### Hot swap recording

When microP2 memory cards are inserted into two microP2 memory card slots, recording can be performed continuously across two cards.

Also, the card other than the one currently being recorded to can be swapped and recording can be continued on three or more cards (hot swap recording).

Note, however, microP2 memory card recognition might slow down depending on the timing (immediately after pre-recording or before and after continuous recording across two card slots) when the microP2 memory card is inserted into the vacant card slot. When inserting microP2 memory card, make sure that there is at least one minute of free space on the card to be recorded to.

Pressing the <SLOT SEL> button allows you to change the slot to be recorded to with one touch.

 NOTE

- You can perform hot swap recording only in the microP2 memory card slot.
- Change slots while recording is on stand-by. You cannot change slots during recording.
- Hot swap playback is not supported.

**Recording check function**

- After recording ends, press the <REC CHECK> button automatically to play back approximately three seconds of the latest video and audio. In this way, you can check whether video has been recorded properly. After playback, the camera is again ready to start recording.
- Hold down the <REC CHECK> button for one second to play back from the last ten seconds of the latest clip. During playback at recording check, press the <REC CHECK> button again to stop the playback.

**Shot mark recording function**

Shot mark is the mark added to the thumbnail of each clip to distinguish that clip from others. Only clips with shot marks attached can be displayed or played back.

**Adding shot marks**

- 1 Assign [SHOT MARK] to one of [USER1] to [USER8] in the main menu → [USER SW].**
- 2 During recording or a pause after recording, press the button to which the shot mark is assigned.**
  - [MARK ON] is displayed, and the shot mark is added to the most recently recorded clip.
  - Another press of the button displays [MARK OFF] and the shot mark disappears.

 NOTE

- When the shot mark is added during a recording pause, it is added to the clip recorded immediately before.
- Shot marks can also be added while the thumbnail is being displayed. (page 111)
- Shot marks cannot be added during loop recording, interval recording, or one-shot recording. If an operation is invalid, [SHOT MARK INVALID] is displayed when the button is pressed.
- During playback, setting or canceling the shot mark is not available. While pausing the playback, setting or canceling the shot mark is available.
- The following restrictions apply when adding shot marks to combined clips, such as those recorded over multiple microP2 memory cards, or when deleting them.
  - All microP2 memory cards composed of clips must be inserted into the slots.
  - A shot mark is added only to the top clip among combined clips.

**Text memo recording function**

Text memos can be added to any video point while a clip is being recorded or played back.

Only clips with a text memo added can be selected and displayed as thumbnails. Also, thumbnails at text memo positions can be displayed in order and played back from text memo points, and only required portions can be selected and copied. (page 111)

**Adding text memos**

- 1 Assign [TEXT MEMO] to one of [USER1] to [USER8] in the main menu → [USER SW].**
- 2 During recording or a playback, press the button to which the text memo is assigned.**

[TEXT MEMO] is displayed, and the text memo is added to the video clip that was displayed when the button was pressed.

 NOTE

- Up to 100 text memos can be recorded to a single clip.
- Text memos cannot be added during loop recording, interval recording, or one-shot recording. If an operation is invalid, [TEXT MEMO INVALID] is displayed when the button is pressed.

## Convenient shooting functions

### Low angle shooting

When shooting at low angles, releasing the hold cover on the REC button on the handle from the <HOLD> position will allow shooting with the REC button on the handle.

- To prevent accidental operation of the REC button on the handle when it is not in use, keep the hold cover to the <HOLD> position.

### Scan reverse shooting

Set [ON] in the main menu → [SYSTEM MODE] → [SCAN REVERSE] to display and record the image in vertically or horizontally reverse.

### Zebra patterns display

The camera can display two types of zebra patterns.

Press the <ZEBRA> button displays the zebra pattern that is set in the menu.

Zebra patterns can also be displayed in the video from the <GENLOCK IN/VIDEO OUT> terminal according to the menu setting.

The level for zebra pattern display can be set in the main menu → [DISPLAY SETUP].

Item	Description of settings
[ZEBRA1 DETECT]	Sets the extraction level of zebra pattern 1. [0%]...[109%] • Factory setting: [70%]
[ZEBRA2 DETECT]	Sets the extraction level of zebra pattern 2. [0%]...[109%] • Factory setting: [85%]
[ZEBRA2]	Sets on/off of zebra pattern 2 and selects the type. [ON], [SPOT], [OFF] • Factory setting: [SPOT]

[SPOT]: The image level from the setting value of [ZEBRA1 DETECT] to the setting value of [ZEBRA2 DETECT] is displayed in the zebra pattern.

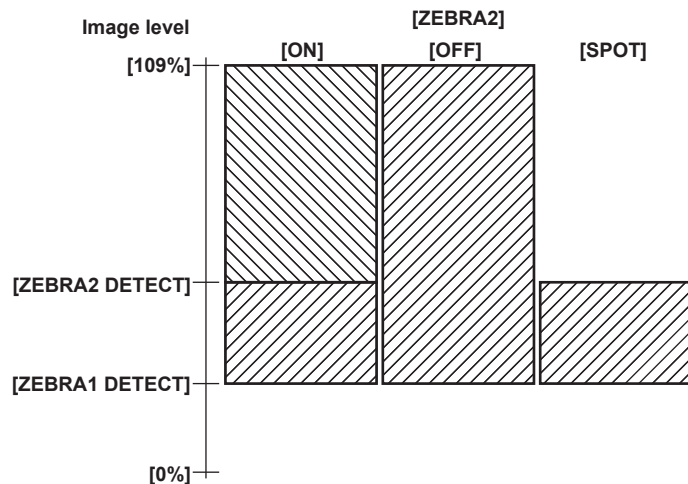

To display the zebra patterns in the video of the monitor output terminal (<GENLOCK IN/VIDEO OUT>), set in the main menu → [OUTPUT SEL] → [VIDEO OUT ZEBRA].

### Displaying the center marker

Displays when setting an item other than [OFF] in the main menu → [DISPLAY SETUP] → [CENTER MARK].

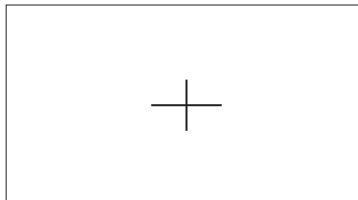

#### NOTE

- The center marker display is not displayed in the images of terminals <SDI OUT>, <GENLOCK IN/VIDEO OUT>, and <HDMI OUT>.

### Displaying the safety zone marker

The items you select the main menu → [DISPLAY SETUP] → [SAFETY MARK] are displayed.

The size of the safety zone marker can be changed in the main menu → [DISPLAY SETUP] → [SAFETY AREA].

 **NOTE**

- The safety zone marker display is not displayed in the images of terminals <SDI OUT>, <GENLOCK IN/VIDEO OUT>, and <HDMI OUT>.

**Displaying frame marker**

Displays when [ON] is set in the main menu → [DISPLAY SETUP] → [FRAME MARK].

Set the angle of view in the main menu → [DISPLAY SETUP] → [FRAME SIG].

Set the outside level in the main menu → [DISPLAY SETUP] → [FRAME LVL].

**Checking and displaying the shooting status**

<DISP/MODE CHK> switch is the spring switch to check the shooting status of the camera during recording standby or recording.

- Pushing this to the <OFF> side will hide all displays other than operation status displays on the viewfinder and LCD monitor screens, frame display of the area, counter, marker, and safety zone displays.
- Pushing this towards the <CHK> side will display information on the screen such as setting status of all shooting functions, the list of functions assigned to the USER buttons, etc. Each press of the button switches the information page.

**Changing image size**

When recording in 480i/576i mode, you can change the size (aspect ratio) of the recorded image. Select the main menu → [SYSTEM MODE] → [ASPECT CONV].

**[SIDE CROP]:** Record using standard 4:3 mode. Cut both the left and right edges.

**[LETTER BOX]:** Record 16:9 the angle of view. A black band is recorded at the top and bottom of the screen. When set to [LETTER BOX], black bands at the top and bottom are not displayed because the screen size of the viewfinder and LCD monitor is 16:9. [LT.BOX] is displayed on the screen.

**[SQUEEZE]:** Camera images are compressed in the horizontal direction when recording. Replaying recorded images on a TV monitor that supports a wide screen will convert the images to an aspect ratio of 16:9.

**Image stabilization function**

The image stabilizer function will reduce the amount of hand shake on the image when you shoot while holding the camera recorder in your hand.

The image stabilizer can be switched from enabled/disabled with the <OIS> button.

When the image stabilizer is enabled,  is displayed in the viewfinder and LCD monitor.

When using a tripod, disabling the image stabilizer function will allow you to obtain natural images.

 **NOTE**

- When there is a lot of shaking while shooting and when following a moving subject, the function may not be able to stabilize the image.

**Dynamic range stretcher function**

You can increase the dynamic range by compressing the image signal for the extremely bright areas that are overexposed during normal shooting while maintaining contrast.

The knee function, black gamma function, and gamma mode function do not work when the dynamic range stretcher function is activated.

Select [ON] in the main menu → [SCENE FILE] → [DRS] to operate.

You can change the level of compression in the main menu → [SCENE FILE] → [DRS EFFECT DEPTH].

[ON]/[OFF] of [DRS] can be assigned to the USER button.

**Backlight compensation**

When shooting a subject in backlight, press the USER button to which the [BACKLIGHT] function is assigned.

The [BACK] is displayed on the screen.

The auto iris control for the backlight compensation prevents darkening of the image of the subject.

Press the USER button again to cancel backlight compensation.

**Color bars**

Pressing the <BARS> button allows you to display the color bars, which are a convenient tool for adjusting image quality on a TV or external monitor.

Pressing this button again returns the view to the original image.

Four types of color bar ([SMPTE]/[FULL BARS]/[SPLIT]/[ARIB]) can be selected in the main menu → [SW MODE] → [BARS TYPE].

**Time stamp function**

You can record the date and time of shooting on the images.

Select [ON] in the main menu → [RECORDING SETUP] → [TIME STAMP].

When the time stamp function is [ON], [R] is displayed at the top of the date and time display on the viewfinder and LCD monitor.

- [R] is not recorded on the actual image.
- Depending upon the shooting format, the size and location of the lettering of the date and time recorded on the image will be different.
- The recorded details will change depending on the settings in the main menu → [DISPLAY SETUP] → [DATE/TIME]. It will not be recorded when the camera is set to [OFF].

 **NOTE**

- Image on the viewfinder and LCD monitor, and the actual time stamp recorded in the video on <SDI OUT>, <GENLOCK IN/VIDEO OUT>, and <HDMI OUT> terminals are not displayed. Video recorded in media includes time stamp.

- Date and time is recorded at the lower right of the video. It is different from the position of the date and time displayed in the viewfinder and LCD monitor.

### Deleting last clip function

You can delete the last clip you shot.

Press the USER button to which [DEL LAST CLIP] is assigned, [YES]/[NO] appears on the screen.

Select [YES] to delete the last shot clip, [LAST CLIP DELETE OK] appears on the screen.

Not to delete the clip, select [NO].

### Waveform monitor function

Press the <WFM> button to display the image waveform. Press the button again to return to the normal display.

- The waveform and vector displays can be switched using [WFM MODE] in the main menu → [SW MODE]. The waveform display will only be displayed on the LCD monitor. The viewfinder does not show the waveform.
- The waveform is not displayed while the focus assist function [EXPAND] is active.
- The waveform display cannot be recorded.

### Direct menu operation

This function changes the settings of values for shutter speed, synchro scan shutter speed, white balance, and frame rate that are displayed on the screen using the <MODE/MENU CANCEL> button.

- Variable frame rate mode can be selected only when [ON] is selected in the main menu → [SCENE FILE] → [VFR].
- White balance variable mode can be selected only when [VAR] is set in the main menu → [SW MODE] → [W.BAL PRESET], and the <WHITE BAL> switch is set to the <PRST> position.

#### **1 Press the <MODE/MENU CANCEL> button and select an item to be changed.**

Every press of the button shows orange highlight on the selected mode.

#### **2 Turn the <SEL/PUSH SET> dial button upward/downward and change the settings.**

#### **3 Press the <MODE/MENU CANCEL> button several times until the highlight of the mode disappears.**

## Multi formats

### Selecting recording signals

This camera can record HD (1080P, 1080i, 720P) signals in a combined format of AVC-Intra, AVC-LongG, and DVCPRO HD codecs, and can record SD (480i/576i) signals in a combined format of DVCPRO50, DVCPRO, and DV codecs.

Recording and shooting signals can be selected in the main menu → [SYSTEM MODE].

Setting		Description of settings
[SYSTEM MODE]	[LINE&FREQ]	Select the signal format from 1080P/1080i/720P/480i/576i. If this setting has been changed, select [YES] on a confirmation message and restart the camera.
	[REC FORMAT]	Select the codec of AVC-Intra, AVC-LongG, and DVCPRO HD in the HD mode, and select the codec of DVCPRO50, DVCPRO, and DV in the SD mode.
	[AUDIO SMPL RES]	Select the number of audio bits ([24BIT] or [16BIT]) when [REC FORMAT] is [AVC-I100] or [AVC-I50]. At [REC FORMAT] other than these, recording is performed at the number of audio bits fixed to 24 bits or 16 bits. For details, refer to "System modes and recording functions" (page 74).
	[ASPECT CONV]	In the SD mode, select the video aspect ratio for recording and output.

#### NOTE

- When [LINE&FREQ] or [REC FORMAT] is changed, video or audio may be interrupted. This is not a malfunction.

### System modes and recording functions

The following shows the relationship between system modes and recording functions on this camera.

- "✓" are supported, and "—" are not supported.

System mode				Recording function		
[LINE&FREQ]	[REC FORMAT]	[CAMERA MODE]	[AUDIO SMPL RES]	Standard recording	Pre-recording	Interval recording
[1080-59.94P]	[AVC-I200/30PN]	—	[24BIT]	✓	—	—
	[AVC-I200/24PN]	—		✓	—	—
	[AVC-I100/60P]	—	[24BIT]/[16BIT]	✓	✓	✓
	[AVC-I100/30PN]	—		✓	—	—
	[AVC-I100/24PN]	—	[24BIT]	✓	—	—
	[AVC-G50/30PN]	—		✓	—	—
	[AVC-G50/24PN]	—		✓	—	—
	[AVC-G25/60P]	—		✓	✓	—
	[AVC-G25/30PN]	—		✓	—	—
	[AVC-G25/24PN]	—		✓	—	—
	[AVC-G12/60P]	—	[16BIT]	✓	✓	—
	[AVC-G12/30PN]	—		✓	—	—
	[AVC-G12/24PN]	—	✓	—	—	
	[1080-50P]	[AVC-I200/25PN]	—	[24BIT]	✓	—
[AVC-I100/50P]		—	[24BIT]/[16BIT]	✓	✓	✓
[AVC-I100/25PN]		—		✓	—	—
[AVC-G50/25PN]		—	[24BIT]	✓	—	—
[AVC-G25/50P]		—		✓	✓	—
[AVC-G25/25PN]		—		✓	—	—
[AVC-G12/50P]		—	[16BIT]	✓	✓	—
[AVC-G12/25PN]	—	✓		—	—	
[1080-59.94i]	[AVC-I200/60i]	—	[24BIT]	✓	—	—
	[AVC-I100/60i]	—	[24BIT]/[16BIT]	✓	✓	✓
	[AVC-I50/60i]	—		✓	✓	✓
	[AVC-G50/60i]	—	[24BIT]	✓	✓	—
	[AVC-G25/60i]	—		✓	✓	—
	[AVC-G12/60i]	—		✓	✓	—
	[DVCPRO HD/60i]	—	[16BIT]	✓	✓	✓
[1080-50i]	[AVC-I200/50i]	—	[24BIT]	✓	—	—
	[AVC-I100/50i]	—	[24BIT]/[16BIT]	✓	✓	✓
	[AVC-I50/50i]	—		✓	✓	✓
	[AVC-G50/50i]	—	[24BIT]	✓	✓	—
	[AVC-G25/50i]	—		✓	✓	—
	[AVC-G12/50i]	—		✓	✓	—
	[DVCPRO HD/50i]	—	[16BIT]	✓	✓	✓



Chapter 4 Shooting — Multi formats

System mode				Recording function		
[LINE&FREQ]	[REC FORMAT]	[CAMERA MODE]	[AUDIO SMPL RES]	Standard recording	Pre-recording	Interval recording
[1080-23.98PsF]	[AVC-I200/24PN]	—	[24BIT]	✓	—	—
	[AVC-I100/24PN]	—	[24BIT]/[16BIT]	✓	—	—
	[AVC-G50/24PN]	—		✓	—	—
	[AVC-G25/24PN]	—		✓	—	—
	[AVC-G12/24PN]	—		✓	—	—
[720-59.94P]	[AVC-I200/60P]	—	[24BIT]	✓	—	—
	[AVC-I100/60P]	—	[24BIT]/[16BIT]	✓	✓	✓
	[AVC-I100/30PN]	—		✓	—	—
	[AVC-I100/24PN]	—		✓	—	—
	[AVC-I50/60P]	—		✓	✓	✓
	[AVC-G50/60P]	—	[24BIT]	✓	✓	—
	[AVC-G25/60P]	—		✓	✓	—
	[AVC-G12/60P]	—	[16BIT]	✓	✓	—
[DVCPRO HD/60P]	—	✓		✓	✓	
[720-50P]	[AVC-I200/50P]	—	[24BIT]	✓	—	—
	[AVC-I100/50P]	—	[24BIT]/[16BIT]	✓	✓	✓
	[AVC-I100/25PN]	—		✓	—	—
	[AVC-I50/50P]	—		✓	✓	✓
	[AVC-G50/50P]	—		[24BIT]	✓	✓
	[AVC-G25/50P]	—	✓		✓	—
	[AVC-G12/50P]	—	[16BIT]	✓	✓	—
	[DVCPRO HD/50P]	—		✓	✓	✓
[480-59.94i]	[DVCPRO50/60i]	[60i]	[16BIT]	✓	✓	✓
		[30P]		✓	—	—
	[DVCPRO/60i]	[60i]		✓	✓	✓
		[30P]		✓	—	—
	[DV/60i]	[60i]		✓	✓	✓
		[30P]		✓	—	—
[576-50i]	[DVCPRO50/50i]	[50i]	[16BIT]	✓	✓	✓
		[25P]		✓	—	—
	[DVCPRO/50i]	[50i]		✓	✓	✓
		[25P]		✓	—	—
	[DV/50i]	[50i]		✓	✓	✓
		[25P]		✓	—	—

System mode				Recording function		
[LINE&FREQ]	[REC FORMAT]	[CAMERA MODE]	[AUDIO SMPL RES]	One-shot recording	Loop recording	One-clip recording
[1080-59.94P]	[AVC-I200/30PN]	—	[24BIT]	—	—	—
	[AVC-I200/24PN]	—		—	—	—
	[AVC-I100/60P]	—	[24BIT]/[16BIT]	✓	✓	✓
	[AVC-I100/30PN]	—		—	—	—
	[AVC-I100/24PN]	—		—	—	—
	[AVC-G50/30PN]	—		[24BIT]	—	—
	[AVC-G50/24PN]	—	—		—	—
	[AVC-G25/60P]	—	—		✓	—
	[AVC-G25/30PN]	—	—		—	—
	[AVC-G25/24PN]	—	—		—	—
	[AVC-G12/60P]	—	[16BIT]		—	✓
	[AVC-G12/30PN]	—		—	—	—
[AVC-G12/24PN]	—	—		—	—	
	—	—		—	—	
[1080-50P]	[AVC-I200/25PN]	—	[24BIT]	—	—	—
	[AVC-I100/50P]	—	[24BIT]/[16BIT]	✓	✓	✓
	[AVC-I100/25PN]	—		—	—	—
	[AVC-G50/25PN]	—	[24BIT]	—	—	—
	[AVC-G25/50P]	—		—	✓	—
	[AVC-G25/25PN]	—		—	—	—
	[AVC-G12/50P]	—	[16BIT]	—	✓	—
[AVC-G12/25PN]	—	—		—	—	

Chapter 4 Shooting — Multi formats

System mode				Recording function		
[LINE&FREQ]	[REC FORMAT]	[CAMERA MODE]	[AUDIO SMPL RES]	One-shot recording	Loop recording	One-clip recording
[1080-59.94i]	[AVC-I200/60i]	—	[24BIT]	—	—	—
	[AVC-I100/60i]	—	[24BIT]/[16BIT]	✓	✓	✓
	[AVC-I50/60i]	—		✓	✓	✓
	[AVC-G50/60i]	—	[24BIT]	—	✓	—
	[AVC-G25/60i]	—		—	✓	—
	[AVC-G12/60i]	—	[16BIT]	—	✓	—
	[DVCPRO HD/60i]	—		✓	✓	✓
[1080-50i]	[AVC-I200/50i]	—	[24BIT]	—	—	—
	[AVC-I100/50i]	—	[24BIT]/[16BIT]	✓	✓	✓
	[AVC-I50/50i]	—		✓	✓	✓
	[AVC-G50/50i]	—	[24BIT]	—	✓	—
	[AVC-G25/50i]	—		—	✓	—
	[AVC-G12/50i]	—	[16BIT]	—	✓	—
	[DVCPRO HD/50i]	—		✓	✓	✓
[1080-23.98PsF]	[AVC-I200/24PN]	—	[24BIT]	—	—	—
	[AVC-I100/24PN]	—	[24BIT]/[16BIT]	—	—	—
	[AVC-G50/24PN]	—		—	—	—
	[AVC-G25/24PN]	—		—	—	—
	[AVC-G12/24PN]	—		—	—	—
[720-59.94P]	[AVC-I200/60P]	—	[24BIT]	—	—	—
	[AVC-I100/60P]	—	[24BIT]/[16BIT]	✓	✓	✓
	[AVC-I100/30PN]	—		—	—	—
	[AVC-I100/24PN]	—		—	—	—
	[AVC-I50/60P]	—	[24BIT]	✓	✓	✓
	[AVC-G50/60P]	—		—	✓	—
	[AVC-G25/60P]	—		—	✓	—
	[AVC-G12/60P]	—		[16BIT]	—	✓
	[DVCPRO HD/60P]	—	✓		✓	✓
[720-50P]	[AVC-I200/50P]	—	[24BIT]	—	—	—
	[AVC-I100/50P]	—	[24BIT]/[16BIT]	✓	✓	✓
	[AVC-I100/25PN]	—		—	—	—
	[AVC-I50/50P]	—		✓	✓	✓
	[AVC-G50/50P]	—	[24BIT]	—	✓	—
	[AVC-G25/50P]	—		—	✓	—
	[AVC-G12/50P]	—	[16BIT]	—	✓	—
	[DVCPRO HD/50P]	—		✓	✓	✓
[480-59.94i]	[DVCPRO50/60i]	[60i]	[16BIT]	✓	✓	✓
		[30P]		—	—	—
	[DVCPRO/60i]	[60i]		✓	✓	✓
		[30P]		—	—	—
	[DV/60i]	[60i]		✓	✓	✓
		[30P]		—	—	—
[576-50i]	[DVCPRO50/50i]	[50i]	[16BIT]	✓	✓	✓
		[25P]		—	—	—
	[DVCPRO/50i]	[50i]		✓	✓	✓
		[25P]		—	—	—
	[DV/50i]	[50i]		✓	✓	✓
		[25P]		—	—	—

Chapter 4 Shooting — Multi formats

System mode				Recording function	
[LINE&FREQ]	[REC FORMAT]	[CAMERA MODE]	[AUDIO SMPL RES]	Simultaneous recording	Background recording
[1080-59.94P]	[AVC-I200/30PN]	—	[24BIT]	—	—
	[AVC-I200/24PN]	—		—	—
	[AVC-I100/60P]	—	[24BIT]/[16BIT]	—	—
	[AVC-I100/30PN]	—		—	—
	[AVC-I100/24PN]	—		—	—
	[AVC-G50/30PN]	—	[24BIT]	—	—
	[AVC-G50/24PN]	—		—	—
	[AVC-G25/60P]	—		—	✓
	[AVC-G25/30PN]	—		—	—
	[AVC-G25/24PN]	—		—	—
	[AVC-G12/60P]	—	[16BIT]	—	✓
	[AVC-G12/30PN]	—		—	—
[AVC-G12/24PN]	—	—		—	
[1080-50P]	[AVC-I200/25PN]	—	[24BIT]	—	—
	[AVC-I100/50P]	—	[24BIT]/[16BIT]	—	—
	[AVC-I100/25PN]	—		—	—
	[AVC-G50/25PN]	—	[24BIT]	—	—
	[AVC-G25/50P]	—		—	✓
	[AVC-G25/25PN]	—		—	—
	[AVC-G12/50P]	—	[16BIT]	—	✓
[AVC-G12/25PN]	—	—		—	
[1080-59.94i]	[AVC-I200/60i]	—	[24BIT]	—	—
	[AVC-I100/60i]	—	[24BIT]/[16BIT]	✓	✓
	[AVC-I50/60i]	—		✓	✓
	[AVC-G50/60i]	—	[24BIT]	✓	✓
	[AVC-G25/60i]	—		✓	✓
	[AVC-G12/60i]	—		✓	✓
	[DVCPRO HD/60i]	—	[16BIT]	✓	✓
[1080-50i]	[AVC-I200/50i]	—	[24BIT]	—	—
	[AVC-I100/50i]	—	[24BIT]/[16BIT]	✓	✓
	[AVC-I50/50i]	—		✓	✓
	[AVC-G50/50i]	—	[24BIT]	✓	✓
	[AVC-G25/50i]	—		✓	✓
	[AVC-G12/50i]	—		✓	✓
	[DVCPRO HD/50i]	—	[16BIT]	✓	✓
[1080-23.98PsF]	[AVC-I200/24PN]	—	[24BIT]	—	—
	[AVC-I100/24PN]	—	[24BIT]/[16BIT]	—	—
	[AVC-G50/24PN]	—		—	—
	[AVC-G25/24PN]	—		—	—
	[AVC-G12/24PN]	—		—	—
[720-59.94P]	[AVC-I200/60P]	—	[24BIT]	—	—
	[AVC-I100/60P]	—	[24BIT]/[16BIT]	✓	✓
	[AVC-I100/30PN]	—		✓	—
	[AVC-I100/24PN]	—		✓	—
	[AVC-I50/60P]	—	[24BIT]	✓	✓
	[AVC-G50/60P]	—		✓	✓
	[AVC-G25/60P]	—		✓	✓
	[AVC-G12/60P]	—		✓	✓
[DVCPRO HD/60P]	—	[16BIT]	✓	✓	
[720-50P]	[AVC-I200/50P]	—	[24BIT]	—	—
	[AVC-I100/50P]	—	[24BIT]/[16BIT]	✓	✓
	[AVC-I100/25PN]	—		✓	—
	[AVC-I50/50P]	—	[24BIT]	✓	✓
	[AVC-G50/50P]	—		✓	✓
	[AVC-G25/50P]	—		✓	✓
	[AVC-G12/50P]	—	[16BIT]	✓	✓
	[DVCPRO HD/50P]	—		✓	✓

Chapter 4 Shooting — Multi formats

System mode				Recording function		
[LINE&FREQ]	[REC FORMAT]	[CAMERA MODE]	[AUDIO SMPL RES]	Simultaneous recording	Background recording	
[480-59.94i]	[DVCPRO50/60i]	[60i]	[16BIT]	✓	—	
		[30P]		✓	—	
	[DVCPRO/60i]	[60i]		✓	—	
		[30P]		✓	—	
	[DV/60i]	[60i]		✓	—	
		[30P]		✓	—	
[576-50i]	[DVCPRO50/50i]	[50i]	[16BIT]	✓	—	
		[25P]		✓	—	
	[DVCPRO/50i]	[50i]		✓	—	
		[25P]		✓	—	
	[DV/50i]	[50i]		✓	—	
		[25P]		✓	—	
System mode				Recording function		
[LINE&FREQ]	[REC FORMAT]	[CAMERA MODE]	[AUDIO SMPL RES]	Dual codec recording		
				HD proxy*1	SD proxy*2	
[1080-59.94P]	[AVC-I200/30PN]	—	[24BIT]	—	—	
	[AVC-I200/24PN]	—		—	—	
	[AVC-I100/60P]	—	[24BIT]/[16BIT]	—	—	
	[AVC-I100/30PN]	—		—	—	
	[AVC-I100/24PN]	—		—	—	
	[AVC-G50/30PN]	—	[24BIT]	—	—	
		[AVC-G50/24PN]		—	—	
		[AVC-G25/60P]		—	—	—
		[AVC-G25/30PN]		—	—	—
		[AVC-G25/24PN]		—	—	—
		[AVC-G12/60P]		—	[16BIT]	—
	[AVC-G12/30PN]	—	—	—		
	[AVC-G12/24PN]	—	—	—		
	[1080-50P]	[AVC-I200/25PN]	—	[24BIT]	—	—
[AVC-I100/50P]		—	[24BIT]/[16BIT]	—	—	
[AVC-I100/25PN]		—		—	—	
[AVC-G50/25PN]		—	[24BIT]	—	—	
[AVC-G25/50P]		—		—	—	
[AVC-G25/25PN]		—		—	—	
[AVC-G12/50P]		—	[16BIT]	—	—	
[AVC-G12/25PN]		—	—	—	—	
[1080-59.94i]	[AVC-I200/60i]	—	[24BIT]	—	—	
	[AVC-I100/60i]	—	[24BIT]/[16BIT]	✓	✓	
	[AVC-I50/60i]	—		—	✓	
	[AVC-G50/60i]	—	[24BIT]	✓	✓	
	[AVC-G25/60i]	—	—	✓	✓	
	[AVC-G12/60i]	—	[16BIT]	—	—	
	[DVCPRO HD/60i]	—	—	—	—	
[1080-50i]	[AVC-I200/50i]	—	[24BIT]	—	—	
	[AVC-I100/50i]	—	[24BIT]/[16BIT]	✓	✓	
	[AVC-I50/50i]	—		—	✓	
	[AVC-G50/50i]	—	[24BIT]	✓	✓	
	[AVC-G25/50i]	—	—	✓	✓	
	[AVC-G12/50i]	—	[16BIT]	—	—	
	[DVCPRO HD/50i]	—	—	—	—	
[1080-23.98PsF]	[AVC-I200/24PN]	—	[24BIT]	—	—	
	[AVC-I100/24PN]	—	[24BIT]/[16BIT]	—	—	
	[AVC-G50/24PN]	—		—	—	
	[AVC-G25/24PN]	—		—	—	
	[AVC-G12/24PN]	—	—	—	—	

System mode				Recording function	
[LINE&FREQ]	[REC FORMAT]	[CAMERA MODE]	[AUDIO SMPL RES]	Dual codec recording	
				HD proxy*1	SD proxy*2
[720-59.94P]	[AVC-I200/60P]	—	[24BIT]	—	—
	[AVC-I100/60P]	—	[24BIT]/[16BIT]	✓	✓*3
	[AVC-I100/30PN]	—		✓	—
	[AVC-I100/24PN]	—		✓	—
	[AVC-I50/60P]	—	[24BIT]	—	✓*3
	[AVC-G50/60P]	—		✓	✓*3
	[AVC-G25/60P]	—		✓	✓*3
	[AVC-G12/60P]	—	[16BIT]	—	—
[DVCPRO HD/60P]	—	—		—	
[720-50P]	[AVC-I200/50P]	—	[24BIT]	—	—
	[AVC-I100/50P]	—	[24BIT]/[16BIT]	✓	✓*3
	[AVC-I100/25PN]	—		✓	—
	[AVC-I50/50P]	—		—	✓*3
	[AVC-G50/50P]	—	[24BIT]	✓	✓*3
	[AVC-G25/50P]	—		✓	✓*3
	[AVC-G12/50P]	—	[16BIT]	—	—
	[DVCPRO HD/50P]	—		—	—
[480-59.94i]	[DVCPRO50/60i]	[60i]	[16BIT]	—	—
		[30P]		—	—
	[DVCPRO/60i]	[60i]		—	—
		[30P]		—	—
	[DV/60i]	[60i]		—	—
		[30P]		—	—
[576-50i]	[DVCPRO50/50i]	[50i]	[16BIT]	—	—
		[25P]		—	—
	[DVCPRO/50i]	[50i]		—	—
		[25P]		—	—
	[DV/50i]	[50i]		—	—
		[25P]		—	—

\*1 [AVC-G6 2CH MOV]

\*2 [SHQ 2CH MOV], [HQ 2CH MOV], [LOW 2CH MOV]

\*3 When [LINE&FREQ] is set to [720-60P] or [720-50P], [LOW 2CH MOV] cannot be selected.

### List of recording settings and recording functions

The recording modes of the camera act as follows depending on the setting of [RECORDING] in the main menu → [RECORDING SETUP]. Even in “Available” cases, recording functions are restricted in some system modes. For details, refer to the table in “System modes and recording functions”.

Setting	Recording setting (setting menu)		Recording/operation enabled/disabled		
	[RECORDING]	[VFR]	Pre-recording	One-clip recording	Simultaneous recording/background recording
Interval recording	[INTERVAL]	Disabled	Not available	Not available	Not available
One-shot recording	[ONE SHOT]	Disabled	Not available	Not available	Not available
Loop recording	[LOOP]	Disabled	Not available	Not available	Not available
Native variable frame rate recording	[NORMAL]	[ON]	Not available	Not available	Not available
Standard variable frame rate recording	[NORMAL]	[ON]	Not available	Not available	Not available
Standard recording	[NORMAL]	[OFF]	Refer to “System modes and recording functions”.		

Setting	Recording setting (setting menu)		Recording/operation enabled/disabled		
	[RECORDING]	[VFR]	Dual codec recording	Text memo	Shot mark
Interval recording	[INTERVAL]	Disabled	Not available	Not available	Not available
One-shot recording	[ONE SHOT]	Disabled	Not available	Not available	Not available
Loop recording	[LOOP]	Disabled	Not available	Not available	Not available
Native variable frame rate recording	[NORMAL]	[ON]	Not available	Available	Available
Standard variable frame rate recording	[NORMAL]	[ON]	Not available	Available	Available
Simultaneous recording/background recording	[NORMAL]	Disabled	Not available	Available	Available
Standard recording	[NORMAL]	[OFF]	Refer to “System modes and recording functions”.		

## Selecting video output

The video output method can be selected.

Video output, etc. can be selected by the setting of [SDI&HDMI SELECT], [3G-SDI OUT], or [DOWNCON MODE] in the main menu → [OUTPUT SEL].

Item	Description of settings
[SDI&HDMI SELECT]	Selects output signals from the <SDI OUT> terminal and <HDMI OUT> terminal.
[3G-SDI OUT]	Selects the 3G-HD SDI signal type output from the <SDI OUT> terminal from [LEVEL-A] and [LEVEL-B] at 1080P.
[DOWNCON MODE]	Selects the mode of the down converter output signal from the <SDI OUT> or <GENLOCK IN/VIDEO OUT> terminal in HD mode (1080P, 1080i, 1080/23.98PsF, or 720P).

## Selecting video output from each terminal

• “—” indicates an item that cannot be selected.

Setting		Video output		
[LINE&FREQ]	[SDI&HDMI SELECT]	<SDI OUT> terminal	<HDMI OUT> terminal	<GENLOCK IN/VIDEO OUT> terminal
[1080-59.94P]	[SYSTEM MODE]	1080/59.94P*1	1080/59.94P	480/59.94i
	[1080i]	1080/59.94i	1080/59.94i	480/59.94i
	[DOWNCON]	480/59.94i	480/59.94P	480/59.94i
[1080-50P]	[SYSTEM MODE]	1080/50P*2	1080/50P	576/50i
	[1080i]	1080/50i	1080/50i	576/50i
	[DOWNCON]	576/50i	576/50P	576/50i
[1080-59.94i]	[SYSTEM MODE]	1080/59.94i	1080/59.94i	480/59.94i
	[DOWNCON]	480/59.94i	480/59.94P	480/59.94i
[1080-50i]	[SYSTEM MODE]	1080/50i	1080/50i	576/50i
	[DOWNCON]	576/50i	576/50P	576/50i
[1080-23.98PsF]	[SYSTEM MODE]	1080/23.98PsF*2	—	480/59.94i
	[DOWNCON]	480/59.94i	—	480/59.94i
[720-59.94P]	[SYSTEM MODE]	720/59.94P	720/59.94P	480/59.94i
	[DOWNCON]	480/59.94i	480/59.94P	480/59.94i
[720-50P]	[SYSTEM MODE]	720/50P	720/50P	576/50i
	[DOWNCON]	576/50i	576/50P	576/50i
[480-59.94i]	—	480/59.94i	480/59.94P	480/59.94i
	—			
	—			
[576-50i]	—	576/50i	576/50P	576/50i
	—			
	—			

\*1 Output type can be selected from [LEVEL-A] and [LEVEL-B] in the main menu → [OUTPUT SEL] → [3G-SDI OUT]. [LEVEL-B] is set in the factory settings.

\*2 When [LINE&FREQ] is set to [1080-23.98PsF] and [SDI&HDMI SELECT] is set to [SYSTEM MODE], video output from the <SDI OUT> terminal in thumbnail mode or playback mode (including recording check) becomes 1080/60P. In addition, it is not output from the <HDMI OUT> terminal. When the mode is changed between the camera mode and thumbnail mode (or playback mode), video signal output from the <SDI OUT> terminal and the <GENLOCK IN/VIDEO OUT> terminal may be disrupted, or video on the LCD monitor and viewfinder may be disrupted.

## Recording/playback and output format list

• Frequencies in signal methods are annotated without fractions.

- 59.94 → 60 / 23.98 → 24 / 29.97 → 30

[LINE&FREQ]	[REC FORMAT]	Setting			Recording format	<SDI OUT> terminal	
		[CAMERA MODE]	[VFR]	[FRAME RATE]		Video format	Audio
[1080-59.94P]	[AVC-I100/60P] [AVC-G25/60P] [AVC-G12/60P]	Disabled	[OFF]	Disabled	1080/60P	1080/59.94P	4ch
	[AVC-I200/30PN] [AVC-I100/30PN] [AVC-G50/30PN] [AVC-G25/30PN] [AVC-G12/30PN]				1080/30PN Native	1080/29.97P over 59.94P 2:2	4ch
	[AVC-I200/24PN] [AVC-I100/24PN] [AVC-G50/24PN] [AVC-G25/24PN] [AVC-G12/24PN]				1080/24PN Native	1080/23.98P over 59.94P 2:3	4ch
	[AVC-I100/60P]	Disabled	[ON]	[1fps] - [60fps]	1080/60P VFR	1080/59.94P VFR	4ch
	[AVC-I100/30PN]				1080/30PN Native VFR*1	1080/59.94P VFR	No audio*2
	[AVC-I100/24PN]				1080/24PN Native VFR*3	1080/59.94P VFR	No audio*4
	[1080-59.94i]	[AVC-I200/60i] [AVC-I100/60i] [AVC-I50/60i] [AVC-G50/60i] [AVC-G25/60i] [AVC-G12/60i]	Disabled	Disabled	Disabled	1080/60i	1080/59.94i
[DVCPRO HD/60i]		1080/60i				1080/59.94i	4ch
[1080-50P]	[AVC-I100/50P] [AVC-G25/50P] [AVC-G12/50P]	Disabled	[OFF]	Disabled	1080/50P	1080/50P	4ch
	[AVC-I200/25PN] [AVC-I100/25PN] [AVC-G50/25PN] [AVC-G25/25PN] [AVC-G12/25PN]				1080/25PN Native	1080/25P over 50P 2:2	4ch
	[AVC-I100/50P]	Disabled	[ON]	[1fps] - [50fps]	1080/50P VFR	1080/50P VFR	4ch
	[AVC-I100/25PN]				1080/25PN Native VFR*5	1080/50P VFR	No audio*6
[1080-50i]	[AVC-I200/50i] [AVC-I100/50i] [AVC-I50/50i] [AVC-G50/50i] [AVC-G25/50i] [AVC-G12/50i]	Disabled	Disabled	Disabled	1080/50i	1080/50i	4ch
	[DVCPRO HD/50i]				1080/50i	1080/50i	4ch
[1080-23.98PsF]	[AVC-I200/24PN] [AVC-I100/24PN] [AVC-G50/24PN] [AVC-G25/24PN] [AVC-G12/24PN]	—	Disabled	Disabled	1080/24PN Native	1080/23.98PsF (in playback or thumbnail display)	4ch
[720-59.94P]	[AVC-I200/60P] [AVC-I100/60P] [AVC-I50/60P] [AVC-G50/60P] [AVC-G25/60P] [AVC-G12/60P]	Disabled	Disabled	Disabled	720/60P	720/59.94P	4ch
	[AVC-I100/30PN]				720/30PN Native	720/30P over 60P 2:2	4ch
	[AVC-I100/24PN]				720/24PN Native	720/24P over 60P 2:3	4ch
	[DVCPRO HD/60P]				720/60P	720/59.94P	4ch
[720-50P]	[AVC-I200/50P] [AVC-I100/50P] [AVC-I50/50P] [AVC-G50/50P] [AVC-G25/50P] [AVC-G12/50P]	Disabled	Disabled	Disabled	720/50P	720/50P	4ch
	[AVC-I100/25PN]				720/25PN Native	720/25P over 50P 2:2	4ch
	[DVCPRO HD/50P]				720/50P	720/50P	4ch

Chapter 4 Shooting — Multi formats

[LINE&FREQ]	[REC FORMAT]	Setting			Recording format	<SDI OUT> terminal	
		[CAMERA MODE]	[VFR]	[FRAME RATE]		Video format	Audio
[480-59.94i]	[DVCPRO50/60i]	[60i]	Disabled	Disabled	480/60i	480/59.94i	4ch
	[DVCPRO/60i] [DV/60i]	[30P]			480/30P over 60i 2:2 Pull Down	480/29.97PsF over 59.94i 2:2	
[576-50i]	[DVCPRO50/50i]	[50i]	Disabled	Disabled	576/50i	576/50i	4ch
	[DVCPRO/50i] [DV/50i]	[25P]			576/25P over 50i 2:2 Pull Down	576/25PsF over 50i 2:2	

\*1 In 30P: 30PN Native audio can be recorded.

\*2 In 30P: 4ch available

\*3 In 24P: 24PN Native audio can be recorded.

\*4 In 24P: 4ch available

\*5 In 25P: 25PN Native audio can be recorded.

\*6 In 25P: 4ch available



## Dual codec recording

Recording in different formats for main recording and sub recording can be performed on the camera.

For sub recording, you can select HD proxy in AVC-LongG 6 format with 1920×1080 resolution or one of three SD proxies with different resolution.

The file format is MOV that is suitable for nonlinear editing.

For the combination with the main recording, refer to “System modes and recording functions” (page 74).

### Dual codec recording setting

#### Setting menu

When recording proxy data with the camera, set in the main menu → [RECORDING SETUP] → [DUAL CODEC SETTING].

Item	Description of settings
[CODEC USAGE]	<p>Selects media for recording proxy data.</p> <p><b>[PROXY REC(P2)]</b>: Records proxy data to a P2 card.</p> <p><b>[PROXY REC(P2&amp;SD)]</b>: Records proxy data to both of a P2 card and SD memory card.</p> <p><b>[STREAMING]</b>: Outputs streaming.</p> <p><b>[OFF]</b>: Does not record proxy data.</p> <ul style="list-style-type: none"> <li>• Factory setting: [OFF]</li> </ul> <p>If the [CODEC USAGE] setting cannot be changed, change the [PROXY REC MODE] or [STREAMING MODE] setting.</p>
[PROXY REC MODE]	<p>Sets the recording mode of proxy data.</p> <p><b>[LOW 2CH MOV]</b>, <b>[HQ 2CH MOV]</b>, <b>[SHQ 2CH MOV]</b>, <b>[AVC-G6 2CH MOV]</b></p> <ul style="list-style-type: none"> <li>• Factory setting: [HQ 2CH MOV]</li> </ul>
[STREAMING MODE]	<p>Sets the transfer mode for streaming.</p> <p><b>[LOW]</b>, <b>[HQ]</b>, <b>[AVC-G6]</b>, <b>[SHQ (QoS)]</b>, <b>[AVC-G (QoS)]</b></p> <ul style="list-style-type: none"> <li>• Factory setting: [HQ]</li> </ul>
[PROXY DISP]	<p>Selects whether to display proxy data recorded information or messages in the viewfinder and LCD monitor.</p> <p><b>[ON]</b>: Displays proxy recording information and SD memory card remaining capacity at the start of recording. Warning information is displayed at all times.</p> <p><b>[OFF]</b>: Displays proxy and SD memory card warning information for only three seconds when warning occurs.</p> <ul style="list-style-type: none"> <li>• Factory setting: [OFF]</li> </ul>

- For details on relations between dual codec recording and system mode, refer to “System modes and recording functions” (page 74).
- If set [AVC-G50] or [AVC-G25] in the main menu → [SYSTEM MODE] → [REC FORMAT] when recording proxy data, set [SPLIT] in the main menu → [RECORDING SETUP] → [FILE SPLIT].

#### Recording modes and recording signals (video/audio)

The following settings are available only when the main recording is set to [1080-59.94i], [1080-50i], [720-59.94P], or [720-50P] in the main menu → [SYSTEM MODE] → [LINE&FREQ].

##### ■ Video

Recording mode	File format	Resolution	Codec	Frame rate	Bitrate
<b>[AVC-G6 2CH MOV]</b>	MOV	1920×1080 *1	H.264 High Profile	30 fps/25 fps	6 Mbps
		1280×720 *2		60 fps/50 fps	
					30 fps/25 fps/24 fps
<b>[SHQ 2CH MOV]</b>	MOV	960×540	H.264 High Profile	30 fps/25 fps	3500 kbps
<b>[HQ 2CH MOV]</b>	MOV	640×360	H.264 High Profile	30 fps/25 fps	1500 kbps
<b>[LOW 2CH MOV]</b>	MOV	480×270	H.264 Baseline Profile	30 fps/25 fps	800 kbps

\*1 When [LINE&FREQ] is [1080-59.94i] or [1080-50i]

\*2 When [LINE&FREQ] is [720-60P] or [720-50P]

##### ■ Audio

Recording mode	File format	Codec	Number of channels	Bitrate per channel	Sampling frequency
<b>[AVC-G6 2CH MOV]</b>	MOV	AAC-LC	2ch	64 kbps	48 kHz
<b>[SHQ 2CH MOV]</b>	MOV	LPCM	2ch	768 bps	48 kHz
<b>[HQ 2CH MOV]</b>	MOV	AAC-LC	2ch	64 kbps	48 kHz
<b>[LOW 2CH MOV]</b>	MOV	AAC-LC	2ch	64 kbps	48 kHz

#### Recording the proxy data

Select [PROXY REC(P2)] or [PROXY REC(P2&SD)] in main menu → [RECORDING SETUP] → [DUAL CODEC SETTING] → [CODEC USAGE] and press the REC button to start proxy recording at the same time as recording of the sources.

Push the <DISP/MODE CHK> switch towards the <CHK> side twice to display the proxy data recording information on the viewfinder and LCD monitor.

## Recording to the SD memory card

To record the proxy data, use SD, SDHC, or SDXC memory cards with an indication of class2 or higher. Refer to our support desk at the following website for the latest information not included in these operating instructions.

<http://pro-av.panasonic.net/>

When recording the proxy data to an SD memory card, always format the card using the camera.

### Checking the SD memory card

#### 1 Insert the SD memory card into the camera.

#### 2 Select the main menu → [CARD FUNCTIONS] → [SD CARD PROPERTY].

- The format status is displayed in [SD STANDARD].  
If [NOT SUPPORTED] is displayed, format the card with the camera.
- In the [PROXY REM] item, check the remaining recording time of the proxy data.  
The remaining SD memory card capacity displayed ([PROXY REM]) indicates the remaining proxy recording, but it may differ from the actual available space. If short recordings are repeated, the available recording time may decrease significantly compared to the available space. When the remaining capacity exceeds 999 min, [999min] is displayed.  
If the proxy is not recorded to the SD memory card, the remaining time is not displayed.
- In the [NUMBER OF CLIPS] item, check the number of clips recorded in the SD memory card.  
If the number of clips is 1000 or more, no additional proxy data can be recorded to the SD memory card even if there is available capacity.
- Shot marks and text memos cannot be added to the clips in the SD memory card.
- Deleting the clips recorded on the P2 card on the thumbnail screen does not delete the proxy data recorded on the SD memory card.

#### NOTE

- While recording to the SD memory card, the remaining capacity can be checked with the mode check on the viewfinder screen.
- If proxy data cannot be recorded to the SD memory card, even when main menu → [RECORDING SETUP] → [DUAL CODEC SETTING] → [CODEC USAGE] → [PROXY REC(P2&SD)] is set, [SD WR ERR] is displayed. In this case, check the SD memory card. For details, refer to “Error displays about proxy data recordings” (page 85).
- Data deleted as a result of formatting cannot be restored. Always check the data before formatting.

### Formatting SD memory cards

#### 1 Insert the SD memory card into the camera.

#### 2 Select [YES] in the main menu → [CARD FUNCTIONS] → [FORMAT SD CARD].

This completes formatting the SD memory card.

### Proxy data recording time (approximate)

Recording mode	Total recording rate	Recording time (per 1 GB)
[AVC-G6 2CH MOV]	Approx. 6 Mbps	Approx. 13 min
[SHQ 2CH MOV]	Approx. 5060 kbps	Approx. 25 min
[HQ 2CH MOV]	Approx. 1650 kbps	Approx. 78 min
[LOW 2CH MOV]	Approx. 950 kbps	Approx. 135 min

(These are reference values for continuous recording with Panasonic products. The recording time may differ depending on the scene or the number of clips)

### Checking the proxy data

- The  indicator is displayed for the material clips with the proxy data recorded.
- The detailed information of the recorded proxy data can be viewed in the clip property.  
For details on operations, refer to “Checking detailed information of the proxy data” (page 85).
- The proxy data is recorded to the P2 card or SD memory card as a video/audio file and real-time metadata file.
  - Audio file: XXXXXXXX.MOV
  - Real-time metadata file:XXXXXXXX.BIN
 The time code, user bits, and information are recorded to the frame unit.  
Use P2 Viewer Plus to check the proxy data. Some versions of P2 Viewer Plus may not be able to check the data.  
For information on P2 Viewer Plus, visit the following website:  
<http://pro-av.panasonic.net/>

#### NOTE

- Clips with proxy data recorded with the camera are handled as unknown clips by some P2 devices.  (unknown clip indicator) is displayed on the thumbnail, and the following operations become unavailable.
  - [DELETE]
  - [REPAIR CLIP]
  - [RE-CONNECTION]
  - [COPY]
  - [EXCH. THUMBNAIL]

- Adding and deleting [TEXT MEMO] and [SHOT MARK]

Playback is possible.

On these devices, clips with proxy data made of linked multiple clips are displayed as individual incomplete clips .

### Checking detailed information of the proxy data

Operation methods and panels may differ by version.

#### 1 Press the <THUMBNAIL> button.

The thumbnail screen appears on the viewfinder screen and LCD monitor.

#### 2 Select [CLIP PROPERTY] in the main menu → [CLIP] → [PROPERTY].

The clip property screen is displayed.

#### 3 Select [PROXY] using the control stick.

#### 4 Press the control stick.

Detailed information about the proxy data is displayed as below.

#### ■ Detailed information about proxy data

[FORMAT]	The file format of the recorded data is displayed.
[VIDEO CODEC]	Video codec information of the recorded data is displayed.
[VIDEO FRAME RATE]	Video frame rate information of the recorded data is displayed.
[VIDEO BIT RATE]	Video bitrate information of the recorded data is displayed.
[VIDEO RESOLUTION]	The video resolution of the recorded data is displayed.
[ASPECT RATIO]	The aspect ratio of the recorded data is displayed.
[TC SUPER]	An indication whether the TC (time code) display is superimposed over the recorded video.
[AUDIO CODEC]	Audio codec information of the recorded data is displayed.
[AUDIO BIT RATE]	Audio bitrate information of the recorded data is displayed.
[AUDIO SAMPLING RATE]	Audio sampling rate information of the recorded data is displayed.
[NUM.OF AUDIO CH]	The number of audio channels of the recorded data is displayed.

### Error displays about proxy data recordings

If an error occurs during recording the proxy data, check the entries in the following table and take necessary actions.

Error displays (viewfinder screen)	Behavior and cause	Action to take
[PROXY ERROR] or [PROXY REC WARNING]	<p>Proxy data recording will stop, but recording of the material will continue.</p> <ul style="list-style-type: none"> <li>• An error occurred in the internal proxy module. [PROXY ERROR]</li> <li>• A proxy data recording error occurred. [PROXY REC WARNING]</li> <li>• If a proxy data recording error occurs, the proxy data currently being recorded will be processed as below: <ul style="list-style-type: none"> <li>- The proxy data being recorded to the P2 card will be deleted.</li> <li>- The proxy data being recorded to the SD memory card will not be restored.</li> </ul> </li> </ul>	<p>The proxy data will not be properly recorded. Turn off the camera and turn it on again to check the recording and playback. If the error continues to occur, please consult your dealer.</p>
[SD 0 min]	<p>Recording of the materials and proxy data will continue.</p> <ul style="list-style-type: none"> <li>• The remaining SD memory card capacity is getting low. (approximately shorter than one minute)</li> </ul>	<p>After finishing recording, insert a new SD memory card.</p>
[SD END]	<p>Proxy data recording to the SD memory card will stop, but recording to the P2 card will continue.</p> <ul style="list-style-type: none"> <li>• No SD memory card capacity remains.</li> </ul>	<p>After finishing recording, insert a new SD memory card.</p> <ul style="list-style-type: none"> <li>• The proxy data being recorded to the SD memory card will be deleted.</li> </ul> <p>To restore the deleted proxy data, select clips in the P2 card and copy them to the SD memory card. (page 86)</p>
[SD WR ERR]	<p>Proxy data recording to the SD memory card will stop, but recording to the P2 card will continue.</p> <p>This is displayed when proxy data cannot be recorded in the SD memory card even though [PROXY REC(P2&amp;SD)] is set in main menu → [RECORDING SETUP] → [DUAL CODEC SETTING] → [CODEC USAGE].</p> <p>■ If the error message is displayed when recording starts:</p> <ul style="list-style-type: none"> <li>• The SD memory card format is different.</li> <li>• The SD memory card contains 1000 clips or more.</li> </ul> <p>■ If the error message is displayed during recording:</p> <ul style="list-style-type: none"> <li>• The SD memory card was ejected during recording.</li> <li>• An error occurred in recording to the SD memory card.</li> </ul>	<p>Check the status of the SD memory card and insert a recordable card. (page 84)</p>

Error displays (viewfinder screen)	Behavior and cause	Action to take
[SD --min] or [SD WP]	Proxy data will not be recorded to the SD memory card, but recording to the P2 card will be performed. <ul style="list-style-type: none"> <li>• No SD memory card is inserted. [SD --min]</li> <li>• The SD memory card is write-protected. [SD WP]</li> </ul>	Check the status of the SD memory card.

### Copying proxy data to the SD memory card

- 1** Press the <THUMBNAIL> button to display the thumbnail screen.
- 2** Use the control stick to move the cursor to the clip to be copied and press the control stick.
- 3** Select [SD CARD] in the main menu → [CLIP] → [COPY].
- 4** Select [YES] in the confirmation message and press the control stick.

#### NOTE

- If [SD END] is displayed and the proxy data being recorded to the SD memory card is deleted, perform this procedure to copy the proxy data from the P2 card, and enable the deleted proxy data to be restored.
- Source data is not copied.

## Streaming function

Using application software compatible with video streaming, streaming of video and audio can be distributed via the network (wired LAN, wireless LAN, 4G/LTE) while recording in the memory card of the camera.

In addition, proxy streaming video of the web application (P2 Browser) can be displayed on a computer.

### Setting the network connection

Configure the network settings of the camera according to the settings of application software compatible with video streaming. For details, refer to “Network Connection” (page 173).

### Setting the streaming function

Enable the streaming function on the camera, and set the streaming mode.

**1** Select [STREAMING] in the main menu → [RECORDING SETUP] → [DUAL CODEC SETTING] → [CODEC USAGE].

Streaming function is enabled.

**2** Set the streaming mode in the main menu → [RECORDING SETUP] → [DUAL CODEC SETTING] → [STREAMING MODE].

- Select either [LOW], [HQ], [AVC-G6], [SHQ (QoS)], or [AVC-G (QoS)].
- To display proxy streaming video with a P2 Browser, select [LOW] or [HQ].
- For details on combinations of system modes and streaming modes, refer to the table in “List of system modes and supported streaming output” (page 87).

 **NOTE**

- To display streaming video on P2 Browser, VLC Media Player is required.
- For details on downloading application software which supports video streaming and the operating environment, visit the support desk at the following website:  
<http://pro-av.panasonic.net/>
- The streaming function cannot be used together with the dual codec recording, simultaneous recording, and background recording.
- The streaming function cannot be used together with the rec during upload function.
- If available bandwidth of the network is low and streaming playback is interrupted, this can be improved by selecting a lower bitrate mode in [STREAMING MODE], or selecting either [SHQ (QoS)] or [AVC-G (QoS)]. In addition, if [SHQ (QoS)] or [AVC-G (QoS)] is selected, the terminal that receives streaming data needs to support the QoS function.
- In thumbnail mode or playback mode (including recording check), streaming distribution from the camera stops.

### List of system modes and supported streaming output

The following shows the relationship between system modes and streaming modes on this camera.

- “✓” are supported, and “—” are not supported.

[SYSTEM MODE]		[STREAMING MODE]	
[LINE&FREQ]	[REC FORMAT]	HD streaming [AVC-G6], [AVC-G (QoS)]	SD streaming [HQ], [LOW], [SHQ (QoS)]
[1080-59.94i]	[AVC-I100/60i]	✓	✓
	[AVC-I50/60i]	—	✓
	[AVC-G50/60i]	✓	✓
	[AVC-G25/60i]	✓	✓
[1080-50i]	[AVC-I100/50i]	✓	✓
	[AVC-I50/50i]	—	✓
	[AVC-G50/50i]	✓	✓
	[AVC-G25/50i]	✓	✓
[720-59.94P]	[AVC-I100/60P]	✓	✓*
	[AVC-I50/60P]	—	✓*
	[AVC-G50/60P]	✓	✓*
	[AVC-G25/60P]	✓	✓*
[720-50P]	[AVC-I100/50P]	✓	✓*
	[AVC-I50/50P]	—	✓*
	[AVC-G50/50P]	✓	✓*
	[AVC-G25/50P]	✓	✓*

\* [LOW] cannot be selected.

### List of streaming modes and resolution/frame rates

Streaming mode	Resolution	Codec	Frame rate	Bitrate
[AVC-G6]	1920×1080*1	Video: H.264 High Profile Audio: AAC-LC 2ch	30 fps/25 fps	6 Mbps
	1280×720*2		60 fps/50 fps	
[HQ]	640×360	Video: H.264 Baseline Profile Audio: AAC-LC 2ch	30 fps/25 fps	1500 kbps
[LOW]	480×270		30 fps/25 fps	800 kbps

## Chapter 4 Shooting — Streaming function

Streaming mode	Resolution	Codec	Frame rate	Bitrate
[AVC-G (QoS)]	1920×1080* <sup>1</sup>	Video: H.264 High Profile Audio: AAC-LC 2ch	30 fps/25 fps	Receiving side: Variable depending on the application Maximum 9 Mbps
	1280×720* <sup>2</sup>		60 fps/50 fps	
[SHQ (QoS)]	960×540	Video: H.264 High Profile Audio: AAC-LC 2ch	30 fps/25 fps	Receiving side: Variable depending on the application Maximum 6 Mbps

\*1 When [LINE&FREQ] is [1080-59.94i] or [1080-50i]

\*2 When [LINE&FREQ] is [720-60P] or [720-50P]

## Handling setting data

### Setting data file configuration

Scene files with [F1:] to [F6:] can be saved on the camera according to the settings in the main menu → [SCENE FILE].

Scene file data ([F1:] to [F6:]) can be saved as a file, and up to eight files can be saved on the SD memory card at a time, which can be loaded and used.

Setting menu values can be saved as one user file on the camera, and up to eight files can be saved on the SD memory card.

[USER MENU] settings registered with [USER MENU SEL] can also be saved on or loaded from the camera and the SD memory card at the same time as a user file.

Setting data file structure of the camera is as follows.

#### ■ Scene file

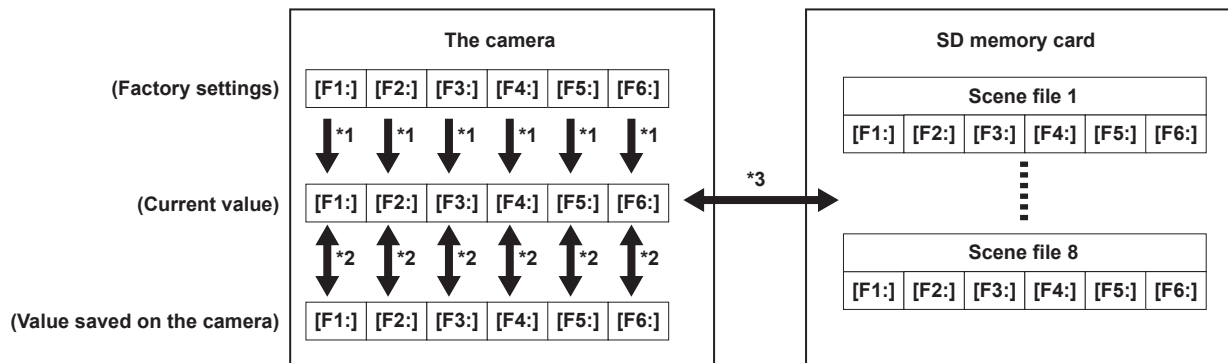

\*1 Select [INITIALIZE] in the main menu → [SCENE FILE] → [LOAD/SAVE/INITIALIZE].

By scene file unit as selected in the main menu → [SCENE FILE] → [FILE SELECT]

\*2 Select [LOAD] or [SAVE] in the main menu → [SCENE FILE] → [LOAD/SAVE/INITIALIZE].

By scene file unit as selected in the main menu → [SCENE FILE] → [FILE SELECT]

\*3 Select [LOAD] or [SAVE] in the main menu → [CARD FUNCTIONS] → [SCENE FILE].

[F1:] to [F6:] at once

#### ■ User file

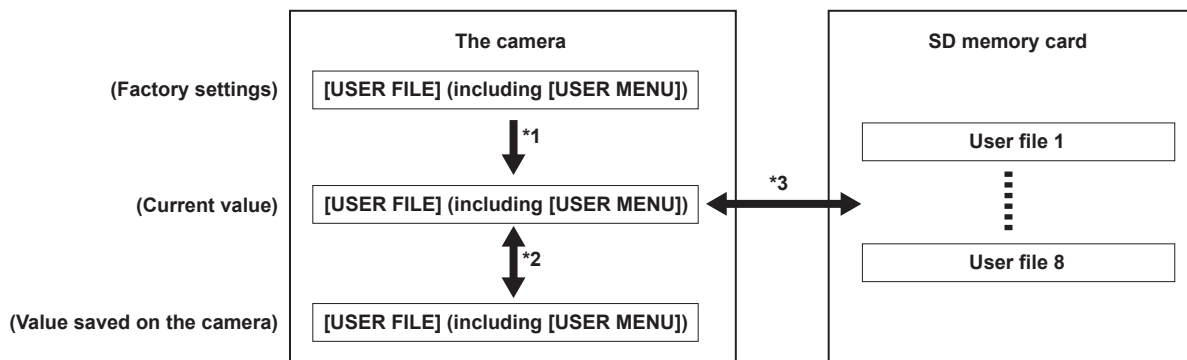

\*1 Select [INITIALIZE] in the main menu → [OTHER FUNCTIONS] → [USER FILE].

\*2 Select [LOAD] or [SAVE] in the main menu → [OTHER FUNCTIONS] → [USER FILE].

\*3 Select [LOAD] or [SAVE] in the main menu → [CARD FUNCTIONS] → [USER FILE].

### Handling SD memory cards

The SD memory card can be removed and inserted, either before or after the power is turned on.

## Inserting SD memory cards

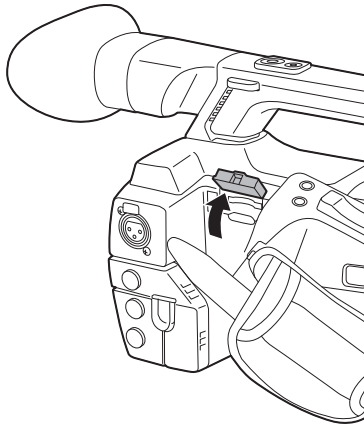

Fig. 1

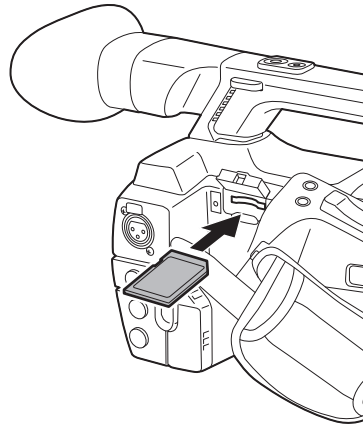

Fig. 2

**1** Open the slot cover. (Fig. 1)

**2** Insert the SD memory card into the SD memory card slot with the label side of the card upward, and close the slot cover. (Fig. 2)

### NOTE

- The SD memory card must be inserted with the correct side facing the SD card slot. If the SD memory card is hard to insert, it may be reversed or upside-down. Do not force it into the slot. Check the orientation of the card before reinserting it.
- On the camera, use SD memory cards that are compliant with the SD, the SDHC, or the SDXC standards.
- For details on handling SD memory cards, refer to “Cautions when using SD memory cards” (page 18).

## Removing SD memory cards

After opening the slot cover and making sure that the busy lamp is not illuminated, push the SD memory card further into the camera and then release. This releases the SD memory card from the card slot. Remove the SD memory card and close the slot cover.

### Note the following points when using or storing memory cards.

- Avoid high temperature and humidity.
- Avoid water droplets.
- Avoid charging with electricity.

Store the SD memory card with the card still inserted into the camera and with the slot cover closed.

## Performing operations on SD memory cards

To perform operations such as formatting an SD memory card, writing setting data to an SD memory card, or reading the written data, use [FORMAT SD CARD] and [SCENE FILE]/[USER FILE] in the main menu → [CARD FUNCTIONS].

If the SD memory card that was formatted in a standard other than the SD/SDHC/SDXC standards on a device other than the camera is inserted, [LOAD] or [SAVE] operation of the file cannot be performed. Format the SD memory card again.

## Formatting SD memory cards

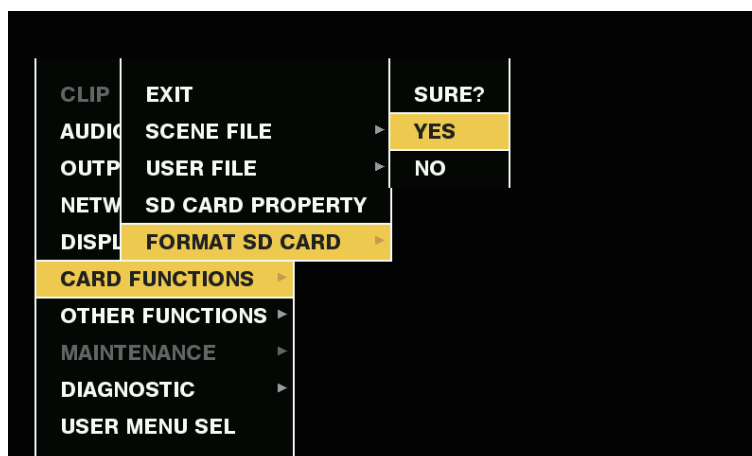

Fig. 1

**1** Select the main menu → [CARD FUNCTIONS] → [FORMAT SD CARD] and press the control stick (or <SEL/PUSH SET> dial button).

The confirmation screen is displayed.



**2 Select [YES] in the confirmation screen and press the control stick (or <SEL/PUSH SET> dial button).** (Fig. 1)

Not to format the memory card, select [NO] and press the control stick (or <SEL/PUSH SET> dial button).

**3 When the completion message is displayed, select [OK] and press the control stick (or <SEL/PUSH SET> dial button).**

For details on error messages, refer to “During thumbnail and menu operation” (page 196).

 **NOTE**

- SD memory cards can also be formatted from the thumbnail screen.  
For details, refer to “Formatting SD memory cards” (page 116).
- Data deleted as a result of formatting cannot be restored. Always check the data before formatting.

**How to use user data**

The content of setting data can be written to and read written data from user area on the internal memory of the camera.

Use of this data allows you to quickly reproduce optimum setup states.

**Writing setting data to user area****1 Select [SAVE] in the main menu → [OTHER FUNCTIONS] → [USER FILE] and press the control stick (or <SEL/PUSH SET> dial button).**

The confirmation screen is displayed.

**2 Select [YES] and press the control stick (or <SEL/PUSH SET> dial button).****3 When the completion message is displayed, press the control stick (or the <SEL/PUSH SET> dial button).****Loading written user data****1 Select [LOAD] in the main menu → [OTHER FUNCTIONS] → [USER FILE] and press the control stick (or <SEL/PUSH SET> dial button).**

The confirmation screen is displayed.

If [SYSTEM RESTART] is displayed on the confirmation screen, the camera will restart after reading out is complete.

**2 Select [YES] and press the control stick (or <SEL/PUSH SET> dial button).**

Loading of the file begins.

**How to use scene file data**

The content of setting data can be written to and read written data from scene file area on the internal memory of the camera. Six types of scene files can be registered. Use of this data allows you to quickly reproduce optimum setup states.

**■ Factory settings**

[F1:]: File that is suitable for standard shooting.

[F2:FLUO.]: The file suitable for shooting when the characteristics of fluorescent light should be considered (such as shooting indoors).

[F3:SPARK]: The file that sharpens the color hue and contrast and that has suitable resolution for SD shooting.

[F4:B-STR]: The file suitable for shooting when the tone level of darker areas are to be stretched (such as shooting at sunset).

[F5:CINE V]: The file suitable for shooting cinematic video that has shaper contrast.

[F6:CINE D]: The file suitable for shooting cinematic video that has wider dynamic range.

 **NOTE**

- [SYSTEM MODE] does not change even if the scene file is changed. Set all items in the main menu → [SYSTEM MODE].

## Saving scene file setting data to the camera memory

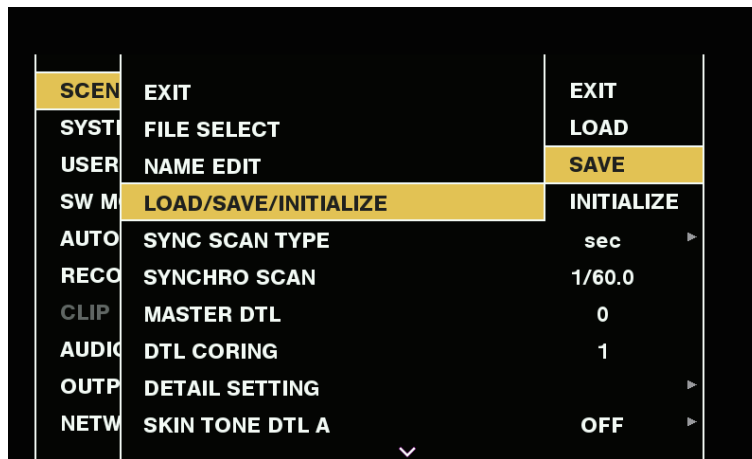

Fig. 1

- 1 Select the file to be saved in the main menu → [SCENE FILE] → [FILE SELECT] and press the control stick (or <SEL/PUSH SET> dial button).
- 2 Select [SAVE] in the main menu → [SCENE FILE] → [LOAD/SAVE/INITIALIZE] and press the control stick (or <SEL/PUSH SET> dial button). (Fig. 1)  
A confirmation screen is displayed.
- 3 Select [YES] and press the control stick (or <SEL/PUSH SET> dial button).  
The selected scene file is saved to the camera.

## Loading the scene file saved in the camera

- 1 Select the file to be loaded in the main menu → [SCENE FILE] → [FILE SELECT] and press the control stick (or <SEL/PUSH SET> dial button).
- 2 Select [LOAD] in the main menu → [SCENE FILE] → [LOAD/SAVE/INITIALIZE] and press the control stick (or <SEL/PUSH SET> dial button).  
The confirmation screen is displayed.
- 3 Select [YES] and press the control stick (or <SEL/PUSH SET> dial button).  
The selected scene file is loaded from the camera.

## Restoring the scene file setting data to the factory settings

- 1 Select the file to be restored to the factory settings in the main menu → [SCENE FILE] → [FILE SELECT] and press the control stick (or <SEL/PUSH SET> dial button).
- 2 Select [INITIALIZE] in the main menu → [SCENE FILE] → [LOAD/SAVE/INITIALIZE] and press the control stick (or <SEL/PUSH SET> dial button).  
The confirmation screen is displayed.
- 3 Select [YES] and press the control stick (or <SEL/PUSH SET> dial button).  
The selected scene file is restored to the factory settings.

## Changing the scene file title

- 1 Select the file to change the title in the main menu → [SCENE FILE] → [FILE SELECT] and press the control stick (or <SEL/PUSH SET> dial button).
- 2 Select [NAME EDIT] in the main menu → [SCENE FILE] and press the control stick (or <SEL/PUSH SET> dial button).  
The title entry screen and keyboard are displayed.
- 3 Enter desired characters on the keyboard using the control stick (or <SEL/PUSH SET> dial button).
- 4 Select [OK] and press the control stick (or <SEL/PUSH SET> dial button).  
The file name is updated.

## How to restore the scene file or menu setting status to the factory settings

All the scene files and menu settings of the camera can be collectively restored to the factory settings.

- 1 Select [MENU INITIALIZE] in the main menu → [OTHER FUNCTIONS] and press the control stick (or <SEL/PUSH SET> dial button).
- 2 Select [EXECUTE] and press the control stick (or <SEL/PUSH SET> dial button).  
[SYSTEM RESTART] indication appears on the confirmation screen.
- 3 Select [YES] and press the control stick (or <SEL/PUSH SET> dial button).  
The camera is restarted and data are restored to the factory settings.

## Saving to an SD memory card and loading saved data

Scene files and other setting values that you have set can be saved as a file, and up to 8 files can be saved on the SD memory card, and saved data can be loaded.

- For scene files, the current setting values are saved in the camera automatically, and you can write the saved data to an SD memory card. When they are loaded from the SD memory card, the current setting values are overwritten as well as the data saved in the camera.
- All scene files [F1:] to [F6:] are overwritten.

### Saving scene files

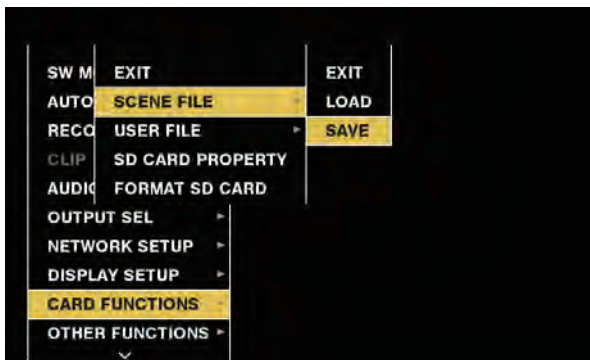

Fig. 1

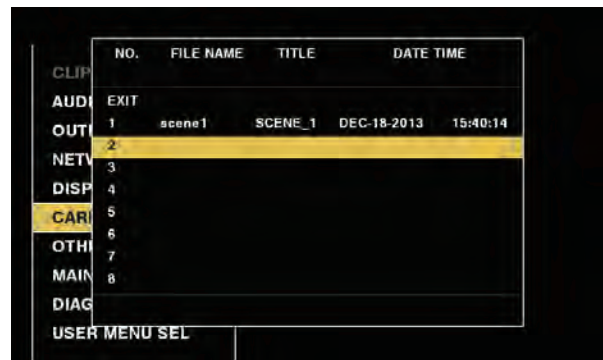

Fig. 2

- 1 Select [SAVE] in the main menu → [CARD FUNCTIONS] → [SCENE FILE]. (Fig. 1)
- 2 Select a file number (1 to 8) and press the control stick (or <SEL/PUSH SET> dial button). (Fig. 2)  
The title entry screen and keyboard are displayed.
- 3 Enter desired characters on the keyboard using the control stick (or <SEL/PUSH SET> dial button).
- 4 Select [OK] on the keyboard and press the control stick (or <SEL/PUSH SET> dial button).  
A confirmation screen is displayed.
- 5 Select [YES] and press the control stick (or <SEL/PUSH SET> dial button).  
The file is written with the entered title on the SD memory card, and the screen of Fig. 2 returns.

### Loading scene files

- 1 Select [LOAD] in the main menu → [CARD FUNCTIONS] → [SCENE FILE].
- 2 Select a file number (1 - 8) and press the control stick (or <SEL/PUSH SET> dial button).  
A confirmation screen is displayed.
- 3 Select [YES] and press the control stick (or <SEL/PUSH SET> dial button).  
When loading is completed, [LOAD OK] is displayed.

### Saving and loading user files

Select [SAVE] or [LOAD] in the main menu → [CARD FUNCTIONS] → [USER FILE]. The operations onward are the same as for scene files.

## Selection of external reference signal and generator lock setting

### Locking the video signal to the external reference signal

The video signal output from the camera can be locked to the reference signal supplied from an external source.  
The camera can receive external reference signals from the <GENLOCK IN/VIDEO OUT> terminal.

### Generator-locking to the reference signal supplied from the <GENLOCK IN/VIDEO OUT> terminal

The HD-Y signal or a composite signal matching the system frame frequency is supplied to the <GENLOCK IN/VIDEO OUT> terminal. To enable the reference signal input to the <GENLOCK IN/VIDEO OUT> terminal, the <IN/OUT> switch needs to be set to <IN>. Select the output signal to lock to the input reference signal from the main menu → [OTHER FUNCTIONS] → [GL PHASE] (in 1080i, 1080P, and 720P only).  
Adjust the horizontal phase of the reference signal and output signal in the main menu → [OTHER FUNCTIONS] → [H PHASE].

#### NOTE

- The subcarrier of the composite signal of the camera is not locked to the subcarrier of the reference signal.

### Output status

The output status changes as follows according to selection of the external reference signal and generator lock setting.  
Set [GL PHASE] in the main menu → [OTHER FUNCTIONS].

Selection of external reference signal		Generator lock setting	Output signal status (phase relationship with external reference signal)
System mode	Input signal	[GL PHASE]	
1080i/1080P	HD-Y	[HD SDI]	HD SDI output matches the HD-Y input signal. Down converter output has a delay of approx. 90 H from the HD-Y input signal.
		[COMPOSITE]	Down converter output matches the HD-Y input signal. HD SDI output has an advance of approx. 90 H from the HD-Y input signal.
	Composite	[HD SDI]	HD SDI output matches the composite input signal. Down converter output has a delay of approx. 90 H from the composite input signal.
		[COMPOSITE]	Down converter output matches the composite input signal. HD SDI output has an advance of approx. 90 H from the composite input signal.
1080/23.98PsF	HD-Y	[HD SDI]	HD SDI output matches the HD-Y input signal.
720P	HD-Y	[HD SDI]	HD SDI output matches the HD-Y input signal. Down converter output has a delay of approx. 120 H from the HD-Y input signal.
		[COMPOSITE]	Down converter output matches the HD-Y input signal. HD SDI output has an advance of approx. 120 H from the HD-Y input signal.
	Composite	[HD SDI]	HD SDI output matches the composite input signal. Down converter output has a delay of approx. 120 H from the composite input signal.
		[COMPOSITE]	Down converter output matches the composite input signal. HD SDI output has an advance of approx. 120 H from the composite input signal.
480i/576i	Composite	—	SD SDI output matches the composite input signal. Composite output matches the composite input signal.
	HD-Y	—	SD SDI output is not locked to the HD-Y input signal. Composite output is not locked to the HD-Y input signal.

#### NOTE

- In the system mode of 1080P or 720P, a genlock is applied to the video signal when the HD-Y signal is input. In this case, time code may shift by one frame.
- Down converter output refers to the output from the <GENLOCK IN/VIDEO OUT> and <SDI OUT> terminals.

## Setting the time data

The camera provides time codes, user bits, and date and time (real time) data as time data, and they are recorded in the frame in sync with video. They are also recorded as data for clip metadata files.

### Definition of time data

#### ■ Time code

It can be switched between [REC RUN] and [FREE RUN] in the main menu → [RECORDING SETUP] → [TCG].

- **[FREE RUN]:** The time code always advances even when the power is turned off, and it can be handled in the same way as time. It can also be slaved to the time code input to the <TC IN/OUT> terminal.
- **[REC RUN]:** Can be regenerated and recorded into the time code of clips recorded to P2 cards as a continuous value.

#### NOTE

- In the following case, the values are not continuous.
  - When deleting recorded clips
  - When switching to 24PN and 30PN (25PN)
  - When recording is interrupted due to a malfunction of [REC WARNING], etc. during recording.

#### ■ User bits

Two types of user bits are built in.

- LTC UB: Recorded as LTC and output from the <TC IN/OUT> terminal. It is also output as LTC of the HD SDI signal.
- VITC UB: Recorded as VITC (recorded to VIDEO AUX area by DVCPRO). It is also output as VITC of the HD SDI signal.

LTC UB can select and record user set values, time, year/month/day, the same value as time codes, camera frame rate information, and input value of external signals from the <TC IN/OUT> terminal, etc.

VITC UB records the camera frame rate information.

The LTC UB value of the recording start time can be recorded on the user bits of the clip metadata.

#### ■ Date/time (real time)

- By means of the internal clock, year, month, day, and time can be displayed on the viewfinder/LCD monitor and on the output image of the <GENLOCK IN/VIDEO OUT> terminal, etc.
- The internal clock is used for measuring the free run time code while the power is off and as time and year/month/day data of the user bits. It is also used as the reference for file generation times during clip recording, which determine the sorting order of thumbnails and the order of playback.
- It is also used to generate clip metadata and UMID (Unique Material Identifier).  
For details, refer to “Setting the date/time of the internal clock” (page 32).

## Recording of time codes and user bits

### Recording of time codes

Setting				Recording TC	
[LINE&FREQ]	[REC FORMAT]	[CAMERA MODE]	[FRAME RATE]	LTC	VITC
[1080-59.94P]	[AVC-I100/60P] [AVC-G25/60P] [AVC-G12/60P]	—	—	Recording run/free run* [DF]/[NDF] 30 frames	Same value as LTC
	[AVC-I200/30PN] [AVC-G50/30PN] [AVC-G25/30PN] [AVC-G12/30PN]		—	Recording run/free run* [DF]/[NDF] 30 frames	
	[AVC-I100/30PN]		[30fps]	Recording run/free run* [DF]/[NDF] 30 valid frames	
			Other than [30fps]	Recording run [DF]/[NDF] 30 valid frames	
	[AVC-I200/24PN] [AVC-G50/24PN] [AVC-G25/24PN] [AVC-G12/24PN]		—	Recording run/free run* [NDF] 24 frames	
			[AVC-I100/24PN]	[24fps]	
	Other than [24fps]	Recording run [NDF] 24 valid frames			
[1080-59.94i]	[AVC-I200/60i] [AVC-I100/60i] [AVC-I50/60i] [AVC-G50/60i] [AVC-G25/60i] [AVC-G12/60i]	—	—	Recording run/free run* [DF]/[NDF] 30 frames	Same value as LTC
	[DVCPRO HD/60i]		—	—	

Chapter 4 Shooting — Setting the time data

Setting				Recording TC	
[LINE&FREQ]	[REC FORMAT]	[CAMERA MODE]	[FRAME RATE]	LTC	VITC
[1080-50P]	[AVC-I100/50P] [AVC-G25/50P] [AVC-G12/50P]	—	—	Recording run/free run* 25 frames	Same value as LTC
	[AVC-I200/25PN] [AVC-G50/25PN] [AVC-G25/25PN] [AVC-G12/25PN]		—	Recording run/free run* 25 frames	
	[AVC-I100/25PN]		[25fps]	Recording run/free run* 25 frames	
			Other than [25fps]	Recording run 25 valid frames	
[1080-50i]	[AVC-I200/50i] [AVC-I100/50i] [AVC-I50/50i] [AVC-G50/50i] [AVC-G25/50i] [AVC-G12/50i]	—	—	Recording run/free run* 25 frames	Same value as LTC
	[DVCPRO HD/50i]		—	—	
[1080-23.98PsF]	[AVC-I100/24PN] [AVC-G50/24PN] [AVC-G25/24PN] [AVC-G12/24PN]	—	—	Recording run/free run* [NDF] 24 frames	Same value as LTC
[720-59.94P]	[AVC-I200/60P] [AVC-I100/60P] [AVC-I100/30PN] [AVC-I50/60P] [AVC-G50/60P] [AVC-G25/60P] [AVC-G12/60P]	—	—	Recording run/free run* [DF]/[NDF] 30 frames	Same value as LTC
	[DVCPRO HD/60P]		—	—	
	[AVC-I100/24PN]		—	Recording run/free run* 24 frames	
[720-50P]	[AVC-I200/50P] [AVC-I100/50P] [AVC-I100/25PN] [AVC-I50/50P] [AVC-G50/50P] [AVC-G25/50P] [AVC-G12/50P]	—	—	Recording run/free run* 25 frames	Same value as LTC
	[DVCPRO HD/50P]		—	—	
[480-59.94i]	[DVCPRO50/60i] [DVCPRO/60i] [DV/60i]	[60i] [30P]	— —	Recording run/free run* [DF]/[NDF] 30 frames	Same value as LTC (No recording in [DV/60i]/[DV/50i])
[576-50i]	[DVCPRO50/50i] [DVCPRO/50i] [DV/50i]	[50i] [25P]	— —	Recording run/free run* 25 frames	Same value as LTC (No recording in [DV/60i]/[DV/50i])

\* For free run, the time code is slaved to the input TC of the <TC IN/OUT> terminal.

Output of time codes

Setting				Output TC	
[LINE&FREQ]	[REC FORMAT]	[CAMERA MODE]	[FRAME RATE]	TC OUT	LTC, VITC of HD SDI
[1080-59.94P]	[AVC-I100/60P] [AVC-G25/60P] [AVC-G12/60P]	—	—	LTC is output.	LTC is output.
	[AVC-I200/30PN] [AVC-G50/30PN] [AVC-G25/30PN] [AVC-G12/30PN]		—	LTC is output.	LTC is output.
	[AVC-I100/30PN]		[30fps]	LTC is output.	LTC is output.
			Other than [30fps]	Matches to the recording TC at the top of recording. 30 frames/second	Matches to the recording TC at the top of recording. 30 frames/second
	[AVC-I200/24PN] [AVC-G50/24PN] [AVC-G25/24PN] [AVC-G12/24PN]		—	LTC is converted to 30 frames and output.	LTC is output.
	[AVC-I100/24PN]		[24fps]	LTC is converted to 30 frames and output.	LTC is output.
			Other than [24fps]	Matches to the recording TC at the top of recording. 30 frames/second	Matches to the recording TC at the top of recording. 30 frames/second

Chapter 4 Shooting — Setting the time data

Setting				Output TC	
[LINE&FREQ]	[REC FORMAT]	[CAMERA MODE]	[FRAME RATE]	TC OUT	LTC, VITC of HD SDI
[1080-59.94i]	[AVC-I200/60i] [AVC-I100/60i] [AVC-I50/60i] [AVC-G50/60i] [AVC-G25/60i] [AVC-G12/60i]	—	—	LTC is output.	LTC is output.
	[DVCPRO HD/60i]	—	—		
[1080-50P]	[AVC-I100/50P] [AVC-G25/50P] [AVC-G12/50P]	—	—	LTC is output.	LTC is output.
	[AVC-I200/25PN] [AVC-G50/25PN] [AVC-G25/25PN] [AVC-G12/25PN]		—	LTC is output.	LTC is output.
			[25fps]	LTC is output.	LTC is output.
	[AVC-I100/25PN]		Other than [25fps]	Matches to the recording TC at the top of recording. 25 frames/second	Matches to the recording TC at the top of recording. 25 frames/second
[1080-50i]	[AVC-I200/50i] [AVC-I100/50i] [AVC-I50/50i] [AVC-G50/50i] [AVC-G25/50i] [AVC-G12/50i]	—	—	LTC is output.	LTC is output.
	[DVCPRO HD/50i]	—	—		
[1080-23.98PsF]	[AVC-I200/24PN] [AVC-I100/24PN] [AVC-G50/24PN] [AVC-G25/24PN] [AVC-G12/24PN]	—	—	LTC is output.	LTC is output.
[720-59.94P]	[AVC-I200/60P] [AVC-I100/60P] [AVC-I100/30PN] [AVC-I50/60P] [AVC-G50/60P] [AVC-G25/60P] [AVC-G12/60P]	—	—	LTC is output.	LTC is output.
	[DVCPRO HD/60P]				
	[AVC-I100/24PN]	—	—	LTC is converted to 30 frames and output.	LTC is converted to 30 frames and output.
[720-50P]	[AVC-I200/50P] [AVC-I100/50P] [AVC-I100/25PN] [AVC-I50/50P] [AVC-G50/50P] [AVC-G25/50P] [AVC-G12/50P]	—	—	LTC is output.	LTC is output.
	[DVCPRO HD/50P]				
[480-59.94i]	[DVCPRO50/60i] [DVCPRO/60i] [DV/60i]	[60i] [30P]	— —	LTC is output.	None
	[DVCPRO50/50i] [DVCPRO/50i] [DV/50i]	[50i] [25P]	— —	LTC is output.	None

## Recording of user bits

Setting				Recording UB	
[LINE&FREQ]	[REC FORMAT]	[CAMERA MODE]	[FRAME RATE]	LTC UB	VITC UB
[1080-59.94P]	[AVC-I100/60P] [AVC-G25/60P] [AVC-G12/60P]	—	—	Follows [UBG MODE].*1	Follows [VITC UBG MODE].*2
	[AVC-I200/30PN] [AVC-G50/30PN] [AVC-G25/30PN] [AVC-G12/30PN]		—		Frame information lock
	[AVC-I100/30PN]		[30fps] Other than [30fps]		
	[AVC-I200/24PN] [AVC-G50/24PN] [AVC-G25/24PN] [AVC-G12/24PN]		—		
	[AVC-I100/24PN]		[24fps] Other than [24fps]		
[1080-59.94i]	[AVC-I200/60i] [AVC-I100/60i] [AVC-I50/60i] [AVC-G50/60i] [AVC-G25/60i] [AVC-G12/60i]	—	—	Follows [UBG MODE].*1	
	[DVCPRO HD/60i]	—	—		
[1080-50P]	[AVC-I100/50P] [AVC-G25/50P] [AVC-G12/50P]	—	—	Follows [UBG MODE].*1	Follows [VITC UBG MODE].*2
	[AVC-I200/25PN] [AVC-G50/25PN] [AVC-G25/25PN] [AVC-G12/25PN]		—		Frame information lock
	[AVC-I100/25PN]		[25fps] Other than [25fps]		Frame information lock
[1080-50i]	[AVC-I200/50i] [AVC-I100/50i] [AVC-I50/50i] [AVC-G50/50i] [AVC-G25/50i] [AVC-G12/50i]	—	—	Follows [UBG MODE].*1	Follows [VITC UBG MODE].
	[DVCPRO HD/50i]	—	—		
[1080-23.98PsF]	[AVC-I200/24PN] [AVC-I100/24PN] [AVC-G50/24PN] [AVC-G25/24PN] [AVC-G12/24PN]	—	—	Follows [UBG MODE].*1	Frame information lock
[720-59.94P]	[AVC-I200/60P] [AVC-I100/60P] [AVC-I100/30PN] [AVC-I100/24PN] [AVC-I50/60P] [AVC-G50/60P] [AVC-G25/60P] [AVC-G12/60P]	—	—	Follows [UBG MODE].*1	Frame information lock
	[DVCPRO HD/60P]				
[720-50P]	[AVC-I200/50P] [AVC-I100/50P] [AVC-I100/25PN] [AVC-I50/50P] [AVC-G50/50P] [AVC-G25/50P] [AVC-G12/50P]	—	—	Follows [UBG MODE].*1	Frame information lock
	[DVCPRO HD/50P]				
[480-59.94i]	[DVCPRO50/60i] [DVCPRO/60i] [DV/60i]	[60i] [30P]	— —	Follows [UBG MODE].*1	Follows [VITC UBG MODE].*3
[576-50i]	[DVCPRO50/50i] [DVCPRO/50i] [DV/50i]	[50i] [25P]	— —	Follows [UBG MODE].*1	Follows [VITC UBG MODE].*3

\*1 With [EXT], UB of the &lt;TC IN/OUT&gt; terminal is slaved.

\*2 During standard variable frame rate recording, frame rate information will be fixed.

\*3 When [CAMERA MODE] is set to [30P] and [25P], frame rate information will be fixed.



## Output of user bits

Setting				Output UB		
[LINE&FREQ]	[REC FORMAT]	[CAMERA MODE]	[FRAME RATE]	UB for TC OUT	LTC UB for HD SDI	VITC UB for HD SDI
[1080-59.94P]	[AVC-I100/60P] [AVC-G25/60P] [AVC-G12/60P]	—	—	LTC UB is output.	LTC UB is output.	VITC UB is output.
	[AVC-I200/30PN] [AVC-G50/30PN] [AVC-G25/30PN] [AVC-G12/30PN]		—			
	[AVC-I100/30PN]		[30fps] Other than [30fps]			
	[AVC-I200/24PN] [AVC-G50/24PN] [AVC-G25/24PN] [AVC-G12/24PN]		—	Outputs along to over 60P, based on LTC UB.	Outputs along to over 60P, based on LTC UB.	
	[AVC-I100/24PN]		[24fps] Other than [24fps]			
[1080-59.94i]	[AVC-I200/60i] [AVC-I100/60i] [AVC-I50/60i] [AVC-G50/60i] [AVC-G25/60i] [AVC-G12/60i]	—	—	LTC UB is output.	LTC UB is output.	VITC UB is output.
	[DVCPRO HD/60i]	—	—			
[1080-50P]	[AVC-I100/50P] [AVC-G25/50P] [AVC-G12/50P]	—	—	LTC UB is output.	LTC UB is output.	VITC UB is output.
	[AVC-I200/25PN] [AVC-G50/25PN] [AVC-G25/25PN] [AVC-G12/25PN]		—			
	[AVC-I100/25PN]		[25fps] Other than [25fps]			
[1080-50i]	[AVC-I200/50i] [AVC-I100/50i] [AVC-I50/50i] [AVC-G50/50i] [AVC-G25/50i] [AVC-G12/50i]	—	—	LTC UB is output.	LTC UB is output.	VITC UB is output.
	[DVCPRO HD/50i]	—	—			
[1080-23.98PsF]	[AVC-I200/24PN] [AVC-I100/24PN] [AVC-G50/24PN] [AVC-G25/24PN] [AVC-G12/24PN]	—	—	LTC UB is output.	LTC UB is output.	VITC UB is output.
[720-59.94P]	[AVC-I200/60P] [AVC-I100/60P] [AVC-I100/30PN] [AVC-I50/60P] [AVC-G50/60P] [AVC-G25/60P] [AVC-G12/60P]	—	—	LTC UB is output.	LTC UB is output.	VITC UB is output.
	[DVCPRO HD/60P]					
	[AVC-I100/24PN]	—	—	Outputs along to over 60P, based on LTC UB.	Outputs along to over 60P, based on LTC UB.	VITC UB is output.
[720-50P]	[AVC-I200/50P] [AVC-I100/50P] [AVC-I100/25PN] [AVC-I50/50P] [AVC-G50/50P] [AVC-G25/50P] [AVC-G12/50P]	—	—	LTC UB is output.	LTC UB is output.	VITC UB is output.
	[DVCPRO HD/50P]					
[480-59.94i]	[DVCPRO50/60i] [DVCPRO/60i] [DV/60i]	[60i] [30P]	— —	LTC UB is output.	None	None
[576-50i]	[DVCPRO50/50i] [DVCPRO/50i] [DV/50i]	[50i] [25P]	— —	LTC UB is output.	None	None

## User bits settings

Sets the user bits to be recorded in the sub code area in the main menu → [RECORDING SETUP] → [UBG MODE].

Item	Description
[USER]	Records internal user values. You can set the user value in the main menu → [RECORDING SETUP] → [UB PRESET]. Setting values are held even when the power is turned off. For details, refer to "How to input user bits" (page 100).
[TIME]	Records the time measured by the internal clock.
[DATE]	Records the hour digit of year/month/day/date-time measured by the internal clock.
[EXT]	Records the user bits values currently entered to the <TC IN/OUT> terminal.
[TCG]	Records the time code value.
[FRAME RATE]	Records the camera photo frame rate information. When playing back clips recorded in native format, the same frame rate information as VITC UB is output regardless of the recorded value. Use at this setting when the editing device such as a computer uses the frame rate information of the user bits.
[REGEN]	Reads the user bit last recorded to P2 card that is currently to be recorded to and recording this value as it is.

### NOTE

- When slave-lock to the user bits value input to the <TC IN/OUT> terminal, set to [EXT].
- During slaving, the [UB] display letters are shown with black and white reversed.
- After executing slave once, even if input from the <TC IN/OUT> terminal stops, the slave status will continue. However, in the following cases, the slave status of the user bits will be released.
  - When [UBG MODE] is set to other than [EXT]
  - When [UB PRESET] is executed
  - When the power is turned off
- The internal [USER] value retains the slaved value even after slave lock is released.
- To input external time codes from the <TC IN/OUT> terminal, set the <IN/OUT> switch to the <IN> side.

## How to input user bits

By setting user bits, information such as memos (date, time) up to eight digits long (hexadecimal) can be recorded.

**1** Select [USER] in the main menu → [RECORDING SETUP] → [UBG MODE].

**2** Select the main menu → [RECORDING SETUP] → [UB PRESET].

**3** Set the user bits using the control stick.

- Screen display
  - Push it to the right to move right the digit to be set.
  - Push it to the left to move left the digit to be set.
  - Push it upward to increase the value of the digit to be set by one.
  - Push it downward to decrease the value of the digit to be set by one.

**4** Press the control stick, enter the values of user bits, and exit the user bits settings screen.

**5** Use the <COUNTER> button to display [UBG] and confirm that the set value is displayed.

### NOTE

- If you exit the user bits setting screen without pressing the control stick, the set values are disabled.

## Retention of user bits in memory

User bit settings are automatically recorded and are retained even if the power is turned off.

## Frame rate information recorded on user bits

Saving the frame rate values for the image information shot/saved according to the frame rate set in the main menu → [SYSTEM MODE] to user bits allows you to use the editor (personal computer editing software).

Information is always saved in VITC UB.

In addition, selecting [FRAME RATE] in the main menu → [RECORDING SETUP] → [UBG MODE] saves the information in user bits (LTC UB) as well. The same value as in the frame rate information obtained from VITC UB playback is also output as LTC UB during playback of clips recorded in native format.

## Frame rate information

The relationship between frame rates, image pull-down, and time codes/user bits is as follows.

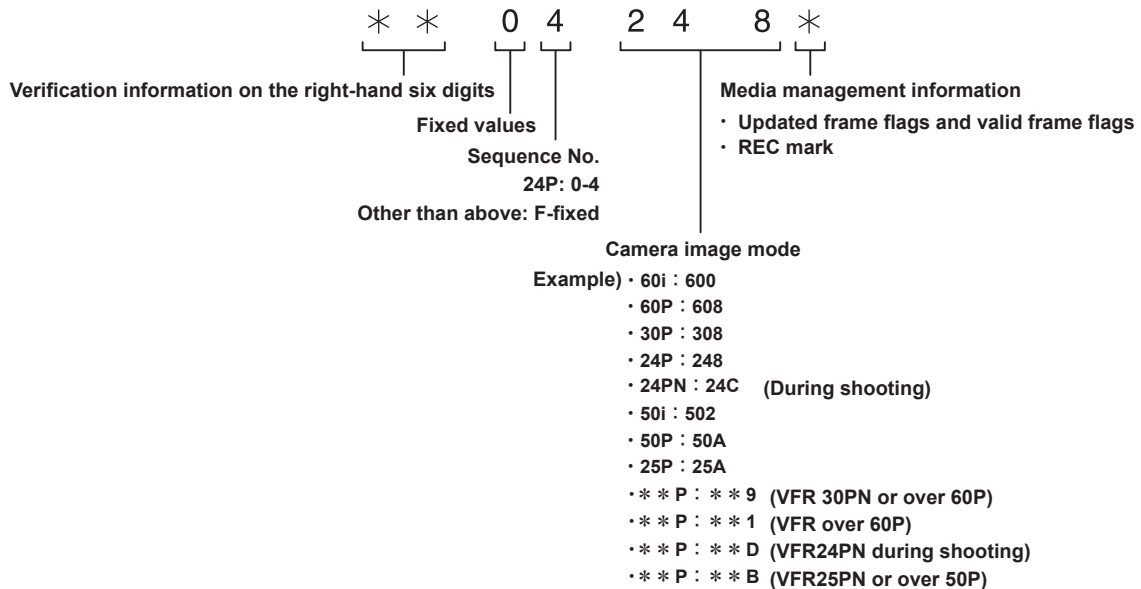

## Setting the time code

### 1 Set the mode for time code in the main menu → [RECORDING SETUP] → [DF MODE]/[TCG].

- [TC MODE] (When 59.94 Hz)  
Sets [DF] (Drop frame mode)/[NDF] (non-drop frame mode).  
In 24PN, the camera always operates in [NDF].
- [TCG]  
Sets [FREE RUN] (free run)/[REC RUN] (recording run).

### 2 Set to [TC PRESET] in the main menu → [RECORDING SETUP].

### 3 Set the time code using the control stick.

- Screen display
  - When pushed down to the right, the digit that has been to set (flashing) moves to the right.
  - When pushed down to the left, the digit that has been to set (flashing) moves to the left.
  - When pushed down toward the top, the value of the digit that has been to set (flashing) is raised by one.
  - When pushed down toward the bottom, the value of the digit that has been to set (flashing) is lowered by one.

### 4 Press the control stick, enter the values of the time code, and exit the time code settings screen.

### 5 Use the <COUNTER> button to display [TC] and confirm that the set value is displayed.

#### Settable time code range

For 59.94 Hz (except for 24PN)	00:00:00:00 to 23:59:59:29
24PN	00:00:00:00 to 23:59:59:23
For 50 Hz	00:00:00:00 to 23:59:59:24

#### NOTE

- When using with 24P, the time code setting is adjusted in 5-frame units. When 24PN, adjusted in multiples of 4, and when 720/30PN and 720/25PN, adjusted to even numbers. Also, the time code cannot be set during recording.
- If you exit the time code setting screen without pressing the control stick, the set values are disabled.
- When the <RESET> button is pressed while in the time code setting screen, the value is reset to 0.

#### Time code function during battery replacement

Even during battery replacement, the backup mechanism functions, allowing the time code generator to continue operating.

When each item of the system mode has been changed, the time code of free run may shift. Turn on the power again, check the time code, and reset it, if necessary.

#### NOTE

- When the power switch has been switched to <ON> → <OFF> → <ON>, the backup accuracy of the time code in the free run mode is approximately ±2 frames.

#### Time codes in variable frame rate

- In 24PN, recording is 24 frames, output is 30 frames, which matches 2:3 pull-down images.
- The advance rate of the recording and output time code matches real time only when the image frame rate is 24P. When 60P, recording advance rate is 60/24 times. In this case, the camera switches to [REC RUN] fixed operation and the time code value that is output when recording starts matches the recording time code.

- It is the same when shooting in modes other than 30P when in 30PN and shooting in modes other than 25P when in 25PN.

## Externally locking the time code

The internal time code generator of the camera can be locked to an external generator. In addition, the time code generator of an external device can be locked to the internal time code generator of the camera.

### Example of connections for external locking

As shown in the figure, connect both the reference video signal and the reference time code.

For details on reference signal and generator lock, refer to “Selection of external reference signal and generator lock setting” (page 94).

#### ■ When locking onto an external signal

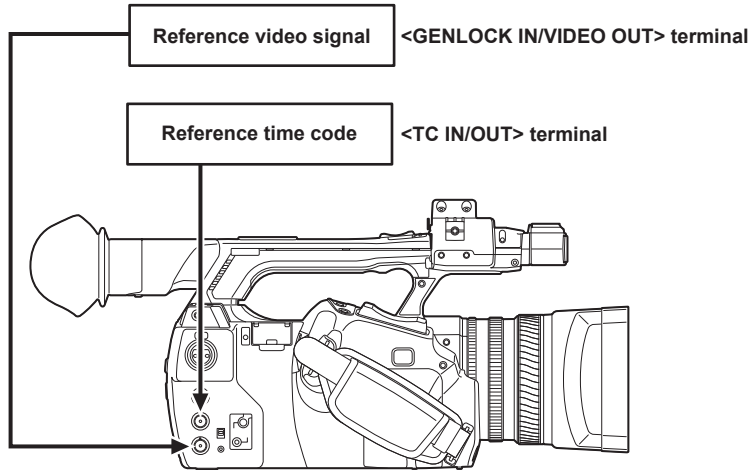

#### NOTE

- To input or genlock input external time code, set the <IN/OUT> switch to <IN> and select [FREE RUN] in the main menu → [RECORDING SETUP] → [TCG].
- You can input Y reference signals of HD and composite video signals as reference videos signals.
- When the system mode is 480i (576i) (SD), 1080P, and 720P, input the composite video signal.
- When the system mode is 1080/23.98PsF, input the HD-Y signal.
- When the system mode is 1080P and 720P, if you input the HD-Y signal, genlock will be applied to the image signal, but the time code may be shifted by one field.
- If the genlock input reference signal becomes disrupted, a normal recording cannot be performed and [TEMPORARY PAUSE IRREGULAR FRM SIG] flashes on the viewfinder and LCD monitor, then clips are divided. The synchronization with the time code is not also guaranteed. Recording will be resumed when the signal returns to normal. However, interval recording, one-shot recording, and loop recording are not resumed.

#### ■ When two cameras are connected and one is used as a reference camera

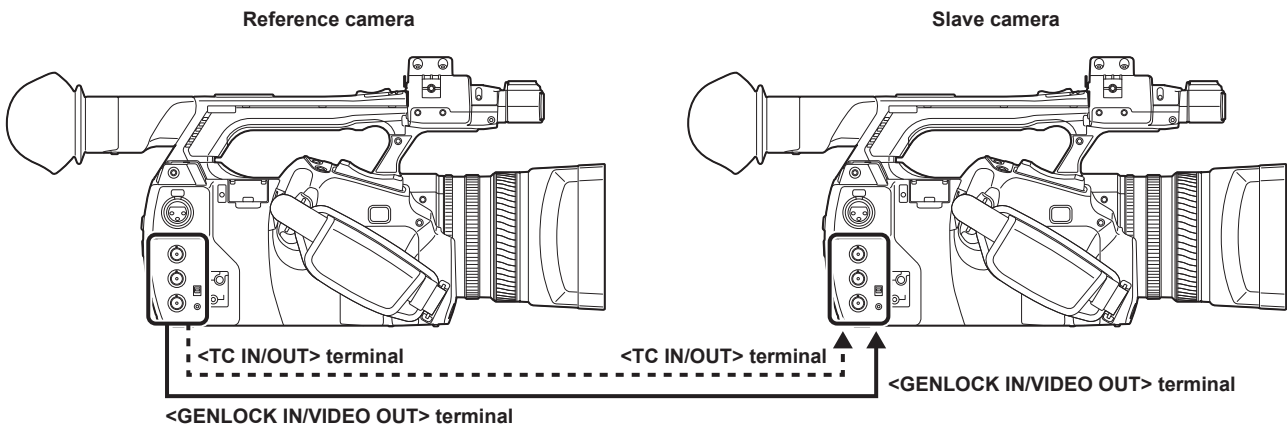

#### NOTE

- Set the <TC IN/OUT> terminal to output or input with the <IN/OUT> switch.
- For all devices, set [RECORDING] in the main menu → [OUTPUT SEL] → [TC OUTPUT REF] and set [COMPOSITE] in the main menu → [OTHER FUNCTIONS] → [GL PHASE].
- If you set [RECORDING] in the main menu → [OUTPUT SEL] → [TC OUTPUT REF], the two cameras will be able to record with the same time code in the image.
- You cannot externally lock the composite signal subcarrier output from the <GENLOCK IN/VIDEO OUT> terminal of the camera.
- When the system mode is 1080/23.98PsF, the following usage is unavailable: connecting two cameras and use one as a reference camera, using the composite signal output from the <GENLOCK IN/VIDEO OUT> terminal.

### External lock operation procedure

To externally lock the time code, follow the steps below.

- 1 Set [FREE RUN] in the main menu → [RECORDING SETUP] → [TCG].
- 2 Display TC with the <COUNTER> button.
- 3 Input a reference time code and reference video signal that are in a phase relationship (that conforms to time code specifications) to the <TC IN/OUT> terminal and the <GENLOCK IN/VIDEO OUT> terminal.

The built-in time code generator is locked to the reference time code. When approximately ten seconds has elapsed after locking, the external lock status will be held even if the reference time code from the external device is disconnected.

- When the input reference signal of generator lock is disrupted, recording cannot be performed normally. [TEMPORARY PAUSE IRREGULAR SIG] is displayed in the viewfinder screen, and the clip is divided. The continuity of the time code is not guaranteed. Recording resumes when the signal returns to normal. However, during loop recording, recording does not resume.
- When the time code is externally locked, the time code is instantaneously locked to the external time code, the same value as the value of the external time code is output to the counter display area. Do not set to the recording mode for several seconds until the sync generator has stabilized. Furthermore, lock the time code to the <TC IN/OUT> terminal signal.
- When using the camera with [ON] set in the main menu → [RECORDING SETUP] → [PRE REC], disrupted images or stopped time codes may be recorded if the time code is switched from recording run to free run immediately before recording or an external time code is input to be slave-locked to the <TC IN/OUT> terminal.
- If you execute the slave once, even if there is no longer <TC IN/OUT> terminal and <GENLOCK IN/VIDEO OUT> terminal input, the slave status is maintained. However, in the following cases, the slave status will be released.
  - When [TC PRESET] is executed
  - When the power is turned off
  - When switching between [DF]/[NDF] in [DF MODE]
  - When [TCG] is set to [REC RUN]
  - When switching between [REC FORMAT] and [CAMERA MODE]

### Setting of user bits when the time code is externally locked

To lock user bits to the input values from an external source, set [EXT] in the main menu → [RECORDING SETUP] → [UBG MODE]. Regardless of the setting of [REC RUN]/[FREE RUN], it is slaved to user bits values input to the <TC IN/OUT> terminal.

### Canceling the external lock

Set [REC RUN] in the main menu → [RECORDING SETUP] → [TCG] after stopping supply of the external time code.

### Cautions when switching the power supply from the battery to the AC adaptor while an external lock is active

To keep continuously on the power supply of the time code generator, connect the AC adaptor to the <DC IN 12V> terminal and then remove the battery pack. If the battery pack is removed first, there is no guarantee that the time code will stay externally locked.

### External synchronization of the camera unit while an external lock is active

While an external lock is active, the genlock is activated on the camera unit by the reference video signal input to the <GENLOCK IN/VIDEO OUT> terminal.

#### NOTE

- To externally lock multiple units with the camera as the master device, set to the same setting as on the camera. Note that in a system using a mixture of interlaced and progressive scanning, the continuity of the video and time codes is not guaranteed.
- When the external lock is applied to 24PN Native, be sure to input non-drop frame time code. External lock is not available in drop frame. Also, at the moment external lock is applied, the image may look corrupted. This is an operation to match the 5-frame cycle and is not a malfunction.

### Supplying the time code externally

You can supply the output time codes to a VTR or other recording device from the camera by matching the camera images or the replayed images.

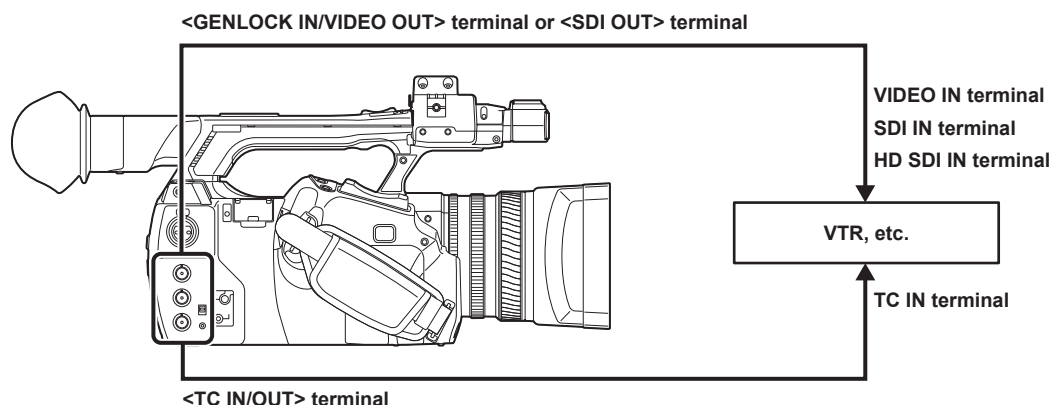

- 1 Set [VIDEO OUT] in the main menu → [OUTPUT SEL] → [TC OUTPUT REF].
- 2 Set [HD SDI] or [COMPOSITE] in the main menu → [OTHER FUNCTIONS] → [GL PHASE] to match the supplied video output.

### 3 Set [TCG/TCR] in the main menu → [OUTPUT SEL] → [TC OUT].

#### NOTE

- If you set [TC OUTPUT REF] to [VIDEO OUT] in the main menu → [OUTPUT SEL], the input time code will be output to match the video output delay.

## Connecting and setting the genlock and time code input/output

The relationship of the connecting and settings between the genlock and time code input/output is shown in the table.

When the genlock input and the camera output phase match, ✓ is displayed, and when they do not match, × is displayed.

#### ■ When the camera recording format is 1080P, 1080i

Camera usage conditions	Image and standard signals supplied externally	SDI	VIDEO	SDI	VIDEO
		Genlock input	1080i		SD (480i/576i)
Camera settings	[GL PHASE]	[HD SDI]	[COMPOSITE]	[HD SDI]	[COMPOSITE]
Genlock input and camera output phase	SDI output (HD)	✓	90H advance	✓	90H advance
	Video output and SDI output (SD)	90H delay	✓	90H delay	✓
	Time code output	✓	✓	✓	✓

#### ■ When the camera recording format is 1080/23.98PsF

Camera usage conditions	Image and standard signals supplied externally	SDI
		Genlock input
Camera settings	[GL PHASE]	[HD SDI]
Genlock input and camera output phase	SDI output (HD)	✓
	Video output and SDI output (SD)	×
	Time code output	✓

#### ■ When the camera recording format is 720P

Camera usage conditions	Image and standard signals supplied externally	SDI	VIDEO	SDI	VIDEO
		Genlock input	720P		SD (480i/576i)
Camera settings	[GL PHASE]	[HD SDI]	[COMPOSITE]	[HD SDI]	[COMPOSITE]
Genlock input and camera output phase	SDI output (HD)	✓	120H advance	✓	120H advance
	Video output and SDI output (SD)	120H delay	✓	120H delay	✓
	Time code output	×	×	✓	✓

#### ■ When the camera recording format is 480i/576i

Camera usage conditions	Image and standard signals supplied externally	SDI	VIDEO
		Genlock input	SD (480i/576i)
Camera settings	[GL PHASE]	Disabled	
Genlock input and camera output phase	SDI output (HD)	None	
	Video output and SDI output (SD)	✓	
	Time code output	✓	

## Setting and displaying the counter

If you display the counter using the <COUNTER> button, the counter value is displayed on the time code display of the viewfinder/LCD monitor. Counter value is displayed as "hour:minute:second.frame". The counter value is also displayed during playback.

You can set either of two types in the main menu → [DISPLAY SETUP] → [REC COUNTER].

**[TOTAL]:** The camera will continuously count until reset using the <RESET> button. Even if you replace the P2 card or turn off the power, the value will be maintained.

**[CLIP]:** Each time you start recording the counter value will clear and the count will start from 0. You can shoot always while checking the recording time of the clip you are currently shooting.

#### NOTE

- If the <RESET> button is pressed while the counter value is displayed, the counter value is reset. It will start again from 0.
- The counter value is displayed by the frame unit.

## Chapter 5 **Playback**

---

Data including additional information such as images, audio, text memo, and metadata that are created from one shooting are saved as a clip. You can play back and edit clips with the camera.

## Basic procedures

### Preparation

- 1 Connect the battery or AC adaptor. (page 25)
- 2 Set the power switch to <ON>. (page 31)
- 3 Open the LCD monitor.

### Playback

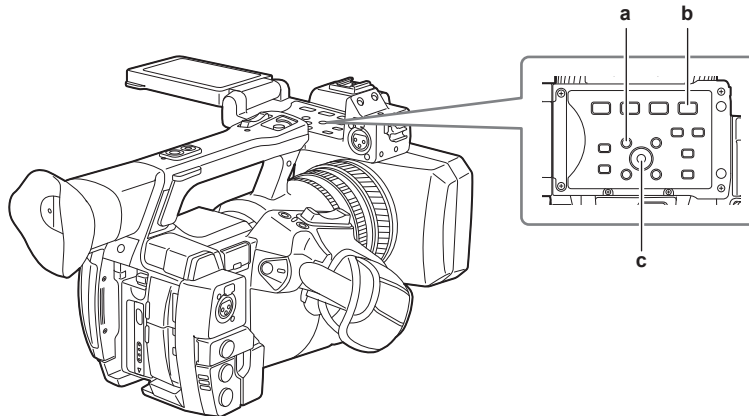

a: <THUMBNAIL> button

b: <▶/||> button

c: Control stick

#### 1 Press the <THUMBNAIL> button.

The thumbnail screen appears on the viewfinder screen.

#### 2 Use the control stick to move the cursor over the clip to be played back.

#### 3 Press the <▶/||> button.

- Playback starts from the beginning of the clip indicated by the cursor.
- After playback of the clip indicated by the cursor ends, the clips will be played back in the order displayed on the thumbnail screen. The screen returns to the thumbnail screen when playback of the last clip ends.
- By changing the thumbnail display settings, you can set it to play clips on a specified slot or clips with an inserted text memo only.
- To change the playback order of clips, select clips in the order you want to play back. Select [SELECTED CLIPS] in the main menu → [CLIP] → [REPOSITION], to display the clips in selected order.
- During playback of clips, press the <◀◀> button to start 4x speed reverse playback, and the <▶▶> button to start 4x speed fast playback. Press the <▶/||> button to return to normal playback.
- During playback of clips, press the <▶/||> button to pause the playback.
  - During a pause, press the <◀◀> button to pause the playback at the beginning of the clip. Press the <◀◀> button again to pause the playback at the beginning of the previous clip.
  - During a pause, press the <▶▶> button to pause the playback at the beginning of the next clip.
  - During a pause, press <+> of the <AUDIO MON/ADV> button to advance a frame, and press <-> to return one frame.
- Pressing the <■> button during clip playback stops the playback and returns the display to the thumbnail screen.

#### NOTE

- When playing clips, it is not necessary to select the clips (blue frames around the thumbnails).
- Clips with clip numbers displayed in red cannot be played back. These are the clips in different video formats (such as 1080i, 480i).
- When playback is stopped, the cursor moves to the position of the clip that was being played back, regardless of where the playback started.
- Press the <▶/||> button again to start playback from the beginning of the clip on which the cursor is placed. To play back from the point where the last playback has been stopped, select [RESUME] in the main menu → [CLIP] → [THUMBNAIL SETUP] → [PB POSITION].
- Playing different compressed recording formats may cause audio and video distortions in between clips.
- Continuously playing clips of the same format but of different audio bit rates mutes the audio in between clips.
- You can play back clips from the text memo position by switching the thumbnail screen to the text memo display. (page 112)
- You can select the playback start position for playback from thumbnails in the main menu → [CLIP] → [THUMBNAIL SETUP] → [PB POSITION].

### Adjusting the audio

You can adjust the output volume from the built-in speaker and headphone terminal.

#### 1 Press <+>/<-> of the <AUDIO MON/ADV> button.



# Thumbnail operations

## Thumbnail operation overview

A clip is a group of data created from one shooting session, which includes additional information such as images, audio, text memo, and metadata that are created from one shooting.

The following operations can be performed while viewing the clip thumbnails displayed on the LCD monitor.

- Play back, delete, copy, or restore clips.
- Adding or deleting a shot mark and text memo to the clip
- Copying part of a clip using the text memo
- Changing the thumbnail image using the text memo
- Format P2 cards and SD memory cards.
- Upload and edit clip metadata from the SD memory card.

## Thumbnail screen

Press the <THUMBNAIL> button to display the thumbnail screen on the LCD monitor. Press the <THUMBNAIL> button again to return to the regular display. Also, when changing from the regular display to the thumbnail screen display, all clips will be displayed on the thumbnail screen.

Press the <MENU> button on the thumbnail screen to enable thumbnail menu operations.















### 1 Status message

A message showing the process status is displayed. [UPDATING] and the icon are displayed while the screen is being refreshed.

### 2 Status displays for card slot, storage device, and network connection

The status conditions of the P2 card, storage device, and network connection are displayed as follows:

(White)	The card slot number in which the P2 card is inserted is displayed in white.
(Yellow)	The card slot number of the P2 card in which the clip in the cursor position is saved is displayed in yellow. If the clips are recorded across multiple P2 cards, all slot numbers of those cards that contain the clips are displayed.
	<b>NOTE</b> The frame turns red if the inserted P2 card is in any of the following conditions: <ul style="list-style-type: none"> <li>• [RUNDOWN CARD] The maximum number of overwrites on the P2 card has been exceeded.</li> <li>• [DIR ENTRY NG CARD] The directory structure on the P2 card is not supported.</li> <li>• [AUTH NG CARD] Indicates that the card is a microP2 memory card which cannot authenticate a CPS password.</li> </ul>
(Gray)	Displayed in gray when a storage device is not connected.
(White)	Displayed in white when a storage device can be used.
(Yellow)	Displayed in yellow when the thumbnails of clips in the storage device are displayed.
(Red)	Displayed in red when a storage device is connected but cannot be used.
(Gray)	Displayed in gray when the wired LAN is not activated properly.
(White)	Displayed in white when the wired LAN is not connected.

 (Yellow)	Displayed in yellow while the wired LAN is active.
 (Red)	Displayed in red when there is a problem with the connection status of wired LAN.
 (Gray)	Displayed in gray when the wireless LAN is not activated properly.
 (White)	Displayed in white when the wireless LAN is not connected.
 (Yellow)	Displayed in yellow while the wireless LAN is active.
 (Red)	Displayed in red when there is a problem with the connection status of wireless LAN.
 (Gray)	Displayed in gray when the 4G/LTE USB modem is not activated properly.
 (White)	Displayed in white when the 4G/LTE USB modem is not connected.
 (Yellow)	Displayed in yellow when the 4G/LTE USB is connected. Signal strength is represented by yellow vertical bars.
 (Red)	Displayed in red when there is a problem with the 4G/LTE USB modem connection.
 (Gray)	Displayed in gray when upload has not started, or upload is complete.
 (Yellow)	Displayed in yellow during upload.
 (Red)	Displayed from when upload error occurred until when the next transfer starts.

 **NOTE**

- When remote control is possible in an IP connection, “R” is displayed on the network status indicator.

**3 Display mode**

Displays the types of the thumbnails to be displayed on the screen and the types of other information screens. To switch between displays, refer to “Setting thumbnail screen display” (page 109).

[ALL]	Displays all clips.
[SAME FORMAT]	Displays clips in the same format as the system format.
[SELECT]	Displays clips selected with the control stick.
[MARKER]	Displays clips with shot marks.
[TEXT MEMO]	Displays clips with text memo data.
[SLOT n]	Displays clips in the specified P2 card. (n: slot numbers 1 to 3 are entered)
[P2/REMAIN]	Displays the media information (remaining capacity).
[NG CLIPS]	Displays defective clips.
[P2/USED]	Displays the media information (used capacity).
[META DATA]	Displays the set metadata.

**4 Simple properties display**

Displays the various properties of the clip on which the pointer is positioned. You can select the items to display from the menu. For details, refer to “Properties” (page 117).

 **NOTE**

- If the maximum number of characters is exceeded, it will only display the maximum number of characters that can be displayed.

**5 Thumbnail**

Displays the thumbnail recorded in each clip. You can change this thumbnail using the [EXCH. THUMBNAIL] function. For details, refer to “Setting thumbnail screen display” (page 109).

**6 Clip information display**

By setting this item, displays either one of the time code [TC]/user bits [UB]/time of shooting [TIME]/date of shooting [DATE]/time and date of shooting [DATE TIME]/clip name [CLIP NAME]/user clip name [USER CLIP NAME]/card slot number [SLOT]/time code of thumbnail [THUMBNAIL TC] at the start of clip recording.

**7 Recording mode**

Displays the recording mode for the clip on which the cursor is positioned.

**8 System format**

Displays the format for the clip on which the cursor is positioned.

**9 Duration**

Displays the clip length (duration) at the cursor position and the current rough playback position against the clip length. Playback position display is enabled when [RESUME] is selected in the main menu → [CLIP] → [THUMBNAIL SETUP] → [PB POSITION]. The approximate playback position is displayed when the playback start position is not at the beginning.

**10 Number of selected clips**

Shows the number of selected clips and the total number of clips.

**11 Clip number**

Displays the number assigned to the clip on the P2 card, normally in the order from the earliest recording date and time. The clip numbers of clips that cannot be played are shown in red, and the unplayable indicator  is also displayed. For details, refer to “Setting thumbnail screen display” (page 109).

**12 Shot mark indicator**

Displayed for the clip of a thumbnail with a shot mark attached. For details, refer to “Shot mark recording function” (page 70).

**13 Indicator for clips with proxy**

Displayed for clips with proxy attached.

**14**  **Text memo indicator**

Displayed for clips with text memo data attached.

**15**  **Edit copied clip indicator**

Displayed for the edit copied clip.

**16**  **Wide clip indicator**

Displayed for clips recorded with the 16:9 aspect ratio. However, it does not accompany clips in HD format.

**17**  **Incomplete clip indicator**

Displayed when clips are saved across multiple P2 cards and either of the P2 cards is not inserted in a card slot.

**18**   **Defective clip indicator**,  **Unknown clip indicator**

Displayed for defective clips, which may result from various causes such as turning off the power during recording.

Clips with yellow defective clip indicators can sometimes be restored.





For details, refer to “Restoring clips” (page 113).

Clips with red defective clip indicators cannot be restored and must be deleted. If the clip cannot be deleted, format the P2 card.

 is displayed for clips which differ in format from the P2 standard.

**19** **Rec during upload status indicator**

Rec during upload status indicator shows the status of maximum 100 clips registered in the upload list as follows.

 (Gray)	Displayed until upload starts.
 (Yellow)	Displayed during upload.
 (Green)	Displayed when upload is completed normally and registered in the upload list.
 (Red)	Displayed when transfer error occurred during upload and registered in the upload list.

**20** **[P.only] indicator**

Displayed for clips with proxy only.

**21** **Thumbnail scroll bar**

Indicates which part of the whole thumbnail is currently being viewed.

**22** **Battery charge level indicator**

 is indicated when the camera is running on the battery, and  is indicated when the camera is running on AC adaptor charging.

## Selecting thumbnails

Multiple thumbnails can be randomly selected on the thumbnail screen.

### Selecting clips

You can select multiple clips randomly.

**1** Use the control stick to move the cursor over the desired clip.

**2** Press the control stick.

A light blue frame and  are displayed on the clip where the cursor is put. This indicates that it is selected.

**3** To select additional clips, repeat steps 1 to 2.

It is possible to display only the selected clips on the thumbnail screen for playback.

 **NOTE**

- While holding down the <SHIFT> button, press the control stick upward/downward to move the cursor to the first/last clip.
- After selecting a clip, move the cursor to another clip and press the control stick while pressing the <SHIFT> button to select all clips from the previously selected clip to the one at cursor position.
- As clips are selected, the number of selected clips displayed on the lower right corner of the screen changes according to the selection.

### Deselecting clips

**1** Move the cursor to the selected clip and press the control stick.

This deselects the clip.

 **NOTE**

- While holding down the <SHIFT> button, press the <EXIT> button to deselect all the clips at once.

## Setting thumbnail screen display

You can customize the thumbnail screen according to usage.

Setting example for thumbnail screen ([INDICATOR])

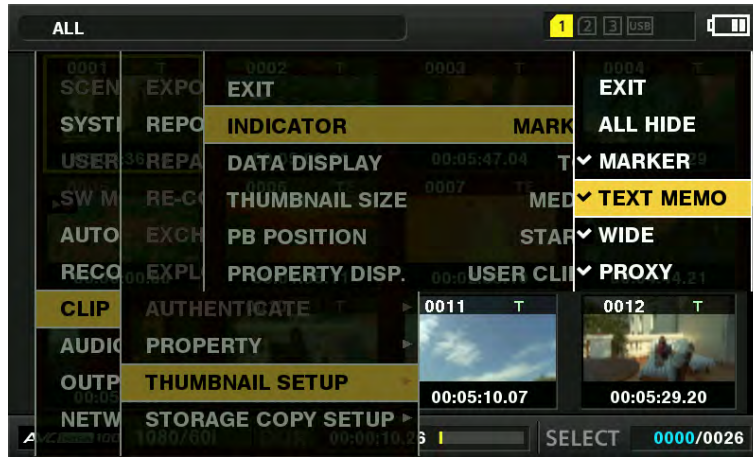

**1** Select [THUMBNAIL SETUP] in the main menu → [CLIP].

The thumbnail setting items ([INDICATOR], [DATA DISPLAY], [THUMBNAIL SIZE], [PB POSITION], [PROPERTY DISP.]) are displayed. For details, refer to “Setting items that display properties” (page 110).

**Setting thumbnails to be displayed**

You can customize the types of clips displayed in the thumbnail screen.

**1** Select [REPOSITION] in the main menu → [CLIP].

**2** Use the control stick to move the cursor to the type of the clip you want to display.

**3** Press the control stick.

**Setting the thumbnail size**

You can customize the thumbnail size.

**1** Select [THUMBNAIL SIZE] in the main menu → [CLIP] → [THUMBNAIL SETUP].

**2** Use the control stick to move the cursor to the size of the thumbnail you want to display.

**3** Press the control stick.

**Setting the clip information display**

You can customize the clip information display contents according to your preference.

**1** Select [DATA DISPLAY] in the main menu → [CLIP] → [THUMBNAIL SETUP].

**2** Use the control stick to move the cursor on the item you want to set.

**3** Press the control stick.

**Setting items that display properties**

You can set simple properties item displayed on the left of the thumbnail.



Fig. 1

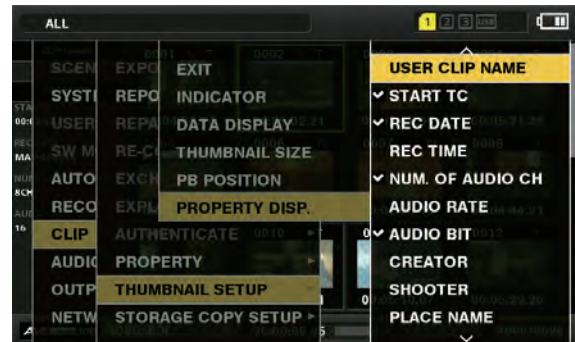

Fig. 2

**1** Open the thumbnail screen. (Fig. 1)

**2** Select [PROPERTY DISP.] in the main menu → [CLIP] → [THUMBNAIL SETUP].

**3** Press the control stick to enter the item menu. (Fig. 2)

The selected item has a check mark on it.

**4 Press the control stick.**

Pressing the control stick will check unchecked items, and uncheck the checked items.

**NOTE**

- Property items can be displayed by selecting [SMALL] in the main menu → [CLIP] → [THUMBNAIL SETUP] → [THUMBNAIL SIZE].
- A maximum of six items can be displayed at the same time.
- When six items are already selected, all unchecked items cannot be selected. You can change your item selection by unchecking selected items.

**Changing thumbnails**

Replace thumbnails with images that include previously attached text memos while images are recorded or played back.

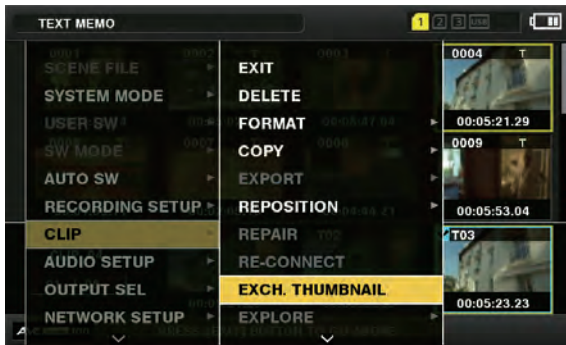

Fig. 1



Fig. 2

**1 Add text memos to images to be changed.**

For details on adding text memos, refer to “Text memo recording function” (page 70).

**2 Select [TEXT MEMO CLIPS] in the main menu → [CLIP] → [REPOSITION] and display the thumbnails of clips with text memos.****3 Move the cursor over the clip that you want to change the thumbnail and press the control stick, and then move the cursor to the text memo display on the lower row.****4 Select thumbnail to be replaced from the text memos, place the cursor on it, and select [EXCH. THUMBNAIL] in the main menu → [CLIP]. (Fig. 1)****5 Press the control stick, and on the confirmation screen displayed, select [YES] using the control stick. (Fig. 2)**

The menu closes and the thumbnail for the clip is replaced.

**NOTE**

- You can view the thumbnail position (number of frames from the top of the clip) from the [THUMBNAIL] item of the clip information display. Since thumbnails usually come from the top of the clip, 0 is displayed.
- Even if you change the thumbnail, playback from the thumbnail screen will still start from the beginning of the clip.
- The thumbnail image with the [!] mark may be displayed for clips of a format with a different number of lines and frequencies when displaying a text memo clip without displaying the thumbnail of the text memo position displayed at the bottom section.

**Shot mark**

Shot marks can be added to a clip thumbnail to distinguish the clip from others.

You must assign [SHOT MARK] to the USER button (USER1 to USER8) beforehand. For details, refer to “Assigning functions to the USER buttons” (page 37).

**1 Use the control stick to move the cursor over the clip to which you want to add a shot mark.****2 Press the USER button to which [SHOT MARK] is assigned.**

- A shot mark is added to the thumbnail of the clip at the cursor position.
- To delete a shot mark, place the cursor on the clip again and press the USER button to which [SHOT MARK] is assigned.

**NOTE**

- You can attach a shot mark during recording.
- Add shot marks after recording stops to attach the shot mark to the most recently recorded clip. For details, refer to “Shot mark recording function” (page 70).
- When adding a shot mark to or deleting the shot mark from a clip recorded across multiple P2 cards, do this with all these P2 cards inserted into card slots.

**Text memo**

You can add text memos during recording or playback. Text memos can be used to play clips at some point or break clips into chunks and copy the necessary portions.



### Adding the text memo

You must assign [TEXT MEMO] to the USER button (USER1 to USER8) beforehand. For details, refer to “Assigning functions to the USER buttons” (page 37).

**1 Press the USER button to which [TEXT MEMO] is assigned while recording, playback, thumbnails.**

- Pressing this button while recording or playing inserts a text memo at the instance when the button was pressed. At that instance, [TEXT MEMO] (when successful) or [TEXT MEMO INVALID] (when unsuccessful) is displayed.
- Pressing this button while the thumbnail screen is displayed inserts a text memo in the clip thumbnail (normally at the beginning) position.

**NOTE**

- Up to 100 text memos can be recorded to a single clip.
- Playback may stop for a moment when the USER button to which [TEXT MEMO] is assigned is pressed. This is not a malfunction.

### Playing back from the text memo position

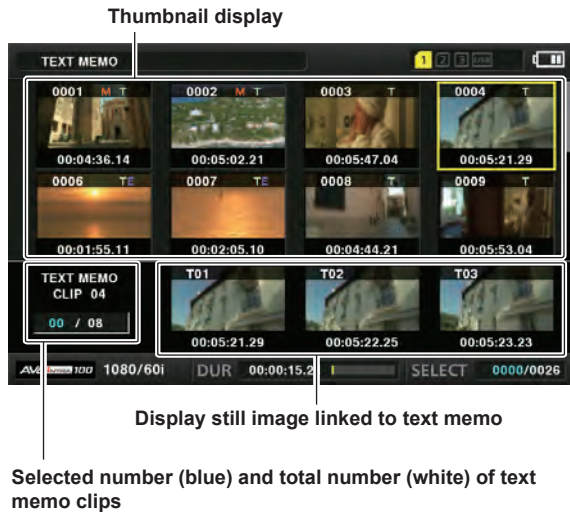

Fig. 1

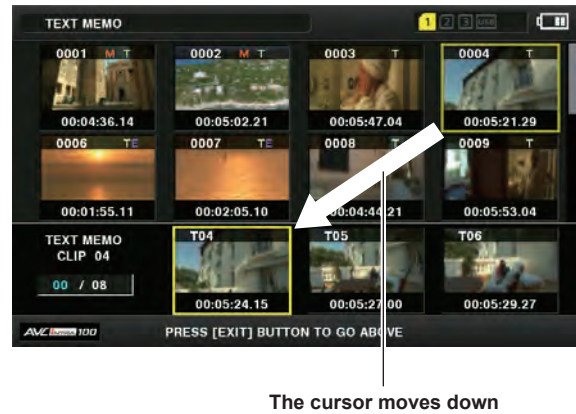

Fig. 2

**1 Select [TEXT MEMO CLIPS] in the main menu → [CLIP] → [REPOSITION].**

The thumbnails of the clips with text memos added are displayed in the upper section of the LCD monitor. The lower section of the LCD monitor shows information on the text memo on the clip selected by the cursor. (Fig. 1)

**2 Move the cursor over the clip that contains the text memo to be played back and press the control stick.**

The cursor moves to the lower section of the LCD monitor. (Fig. 2)

**3 With the cursor located in the lower section, press the control stick to the left/right to move the cursor to the text memo number you want to play back and press the <▶/||> button.**

- Playback starts from the time code position of the text memo where the cursor is located.
  - If the <■> button is pressed during playback or the playback has finished at the end of the clip, the thumbnail screen appears again and the cursor returns to the thumbnail of the text memo where the playback started.
- While holding down the <SHIFT> button, press the control stick upward/downward to move the cursor to the first/last text memo.
- Press the <EXIT> button to return the cursor to the upper section of the thumbnail screen.

**NOTE**

- Pressing the REC button while the text memo screen is displayed does not start recording.
- For clips in AVC-Intra and AVC-LongG formats with different settings (different system frequencies) in the main menu → [SYSTEM MODE], the thumbnail of the text position may not be displayed and a thumbnail image with the [!] mark may be displayed.
- You can hide the text memo indicator of a clip to which a text memo with card serial number is added. Set this in the main menu → [CLIP] → [THUMBNAIL SETUP] → [TEXT MEMO INDICATOR]. (page 140)

### Deleting text memos

**1 Perform steps 1 to 2 in “Playing back from the text memo position” (page 112) to select the desired text memo in a clip.**

**2 Move the cursor over the text memo to be deleted and press the control stick.**

**3 Select [DELETE] in the main menu → [CLIP] and press the control stick.**

**4 Select [YES] using the control stick.**

This deletes the text memo.

### Using a text memo to divide a clip and copy the necessary portion

**1 Perform steps 1 to 2 in “Playing back from the text memo position” (page 112) to select the desired text memo in a clip.**

**2 Move the cursor over the text memo to be copied and press the control stick.**

You can select multiple text memos.

**3 Select [COPY] in the main menu → [CLIP].****4 Select the copy target slot using the control stick and select [YES].**

- Copying starts.
- The portion between the selected text memo and the next one is copied. If no text memo is found after the selected one, then the part after the selected text memo to the end of the clip is copied.
- If multiple text memos are selected, the selected sections are copied.
- While the clip is being copied, the progress of the copy process and cancelation will be displayed. To discontinue the copy process, press the control stick. When the [YES]/[NO] confirmation screen is displayed, use the control stick to select [YES].

 **NOTE**

- In clip division and copying using the text memo, the area copied may be automatically modified and copied depending on the recording method of the clip.

**Deleting clips****1 Use the control stick to move the cursor over the clip to be deleted, and press the control stick to select the clip.****2 Select [DELETE] in the main menu → [CLIP] and press the control stick.****3 Select [YES] using the control stick.**

The clip is deleted. All selected clips (in blue-green frames) are deleted by this operation.

 **NOTE**

- To interrupt the deletion process, press the <SHIFT> button + <EXIT> button or press the control stick to cancel the operation. Once a clip is deleted halfway, it cannot be restored even if the deletion process is aborted.

**Restoring clips**

You can restore clips that were made defective as a result of sudden power-down during recording or removal of the P2 card being accessed.

**1 Use the control stick to move the cursor over the clip to be restored (defective clips are indicated by defective clip marks) and press the control stick to select the clip.****2 Select [REPAIR] in the main menu → [CLIP] and press the control stick.****3 Select [YES] using the control stick.**

This restores the clip.

 **NOTE**

- To find defective clips, set the main menu → [CLIP] → [REPOSITION] to [NG CLIPS]. Only defective clips are displayed. For details, refer to “Setting thumbnails to be displayed” (page 110).
- You can restore clips with yellow defective clip indicators. Delete clips with red defective clip indicators. If the clips cannot be deleted, format the P2 card.
- During restoration of the clips, however, the defective clip indicator may change from yellow to red, and result in the inability to restore the clips.
- When defective clips containing proxy data are restored, proxy data will be deleted.

**Reconnecting incomplete clips**

Incomplete clips may be generated when clips recorded on multiple P2 cards (connected clips) are separately copied from each card. The reconnection function generates one clip (the original, connected clip) from incomplete clips.

**1 Use the control stick to select incomplete clips to be linked.**

Usually, thumbnails of incomplete clips (clips with  indication) are displayed next to each other.

**2 Select [RE-CONNECT] in the main menu → [CLIP] and press the control stick.****3 Select [YES] using the control stick.**

This reconnects incomplete clips.

 **NOTE**

- Incomplete clip indicators will remain displayed when only some clips are reconnected, unless all the constituent clips of the original clip are reconnected.

**Copying clips**

Selected clips can be copied to a P2 card or a connected USB storage device in the desired slot.

**1 Use the control stick to move the cursor over the clip to be copied, and press the control stick to select the clip.****2 Move the cursor to the copy target from the [COPY] list in the main menu → [CLIP] and press the control stick.**

- When multiple clips are selected, the number of selected clips is displayed after pressing the control stick.

- If the copy destination is a storage device, select the copy destination properties.

**3 Move the cursor to [YES] in the confirmation message and press the control stick.**

This starts copying of the clip.

**4 When the completion message appears, press the control stick.**

 **NOTE**

- Turning off the power or inserting/removing a card during copying may damage the P2 card. If you accidentally make these mistakes, it can result in defective clips. After deleting the defective clips redo copying.
- Copying is not performed when the following error messages are displayed.
  - [LACK OF CAPACITY!] Copying could not be performed because the recording capacity of the copy destination is insufficient.
  - [UNKNOWN CONTENTS FORMAT!] Copying could not be performed because a defective clip is selected.
  - [NO COPY TO SAME CARD!] Copying could not be performed because you are attempting to copy to the same card.
  - [TOO MANY CLIPS!] Copying could not be performed because there are too many clips selected.
- If the copying is performed while a text memo is selected in the lower part of the text memo, the section between the selected text memo position and the next text memo will be copied. If no text memo is found after the selected one, then the part after the selected text memo to the end of the clip is copied. For details, refer to “Using a text memo to divide a clip and copy the necessary portion” (page 112).
- To interrupt copying, press the <SHIFT> button + <EXIT> button, or the control stick to cancel the operation. The clip being copied will be deleted from the copy destination.
- When identical clips (same [GLOBAL CLIP ID]) exist on the destination, [OVERWRITE?] is displayed. Select [YES] when overwriting the clip, and select [NO] when not overwriting the clip.

**Setting clip metadata**

Information such as the name of the person who shot the video, the name of the reporter, the shooting location, or text memos can be loaded from an SD memory card, and can be recorded as clip metadata.

**Clip metadata items**

Clip metadata includes the following items. Underlined items can be set by loading the metadata upload file on the SD memory card. Other items are set automatically during shooting. Using the latest update version of P2 Viewer Plus, metadata upload files can be written to SD memory cards using a computer. Download and install the latest version of P2 Viewer Plus from the following website.

<http://pro-av.panasonic.net/>

For details on SD memory cards to be used, refer to “Cautions when using SD memory cards” (page 18).

 **NOTE**

- Files which were not edited by P2 Viewer Plus are displayed as [UNKNOWN DATA!] and may not be readable.

<b>[GLOBAL CLIP ID]</b>	Displays the global clip ID that shows the shooting status of the clip.
<b>[USER CLIP NAME]</b>	Displays the clip name set by the user.*1
<b>[VIDEO]</b>	Displays [FRAME RATE] (frame rate of the clip), [PULL DOWN] (pull-down format), and [ASPECT RATIO].
<b>[AUDIO]</b>	Displays [SAMPLING RATE] (sampling frequency of recorded audio) and [BITS PER SAMPLE] (quantizing bits for recorded audio).
<b>[ACCESS]</b>	Displays [CREATOR] (person who recorded the clip), [CREATION DATE] (date when the clip was recorded), [LAST UPDATE DATE] (date of the latest update of the clip), and [LAST UPDATE PERSON] (person who made the latest update of the clip).
<b>[DEVICE]</b>	Displays [MANUFACTURER] (name of the device manufacturer), [SERIAL NO.] (serial number of the device), and [MODEL NAME] (model name of the device).
<b>[SHOOT]</b>	Displays [SHOOTER] (name of the person who shot the video), [START DATE] (start date of shooting), [END DATE] (end date of shooting), and [LOCATION]/[ALTITUDE]/[LONGITUDE]/[LATITUDE]/[SOURCE]/[PLACE NAME] (altitude, longitude, latitude, and source of the information and name of the location).
<b>[SCENARIO]</b>	Displays [PROGRAM NAME], [SCENE NO.], and [TAKE NO.].
<b>[NEWS]</b>	Displays [REPORTER] (name of the reporter), [PURPOSE] (purpose of shooting), and [OBJECT] (object of shooting).
<b>[MEMO]*2</b>	Displays [NO.] (the number of the text memo), [OFFSET] (location of the frame where the text memo is added), [PERSON] (person who recorded the text memo added to the clip), and [TEXT] (content of the text memo).
<b>[THUMBNAIL]</b>	Displays the location of the frame (frame offset) and the size (height and width) of the image selected as the thumbnail image.
<b>[PROXY]</b>	Displays information such as proxy format when proxy is added.

\*1 You can select the [USER CLIP NAME] recording method. For details, refer to “Selecting the [USER CLIP NAME] recording method” (page 115).

\*2 When entering [MEMO], make sure to enter [TEXT]. It is not possible to record only [PERSON] (the person inputting the memo), or [OFFSET] (the recording position).



Loading clip metadata (metadata upload)



Fig. 1



Fig. 2

- 1 Insert the SD memory card that contains the clip metadata (metadata upload file).
- 2 Select [LOAD] in the main menu → [RECORDING SETUP] → [REC META DATA] and press the control stick.  
The metadata name of the metadata upload file on the SD memory card is displayed. (Fig. 1)
- 3 Use the control stick to select the file to be loaded, and select [YES].
  - Upload starts.
  - Uploaded metadata is retained even if the power is turned off.
  - For confirmation of uploaded data, refer to “Checking and modifying uploaded metadata” (page 115).

**NOTE**

- While displaying metadata names, press the control stick to the right to switch to file name display. (Fig. 2)  
Press the control stick to the left to return to metadata name display.

Checking and modifying uploaded metadata

Details of metadata uploaded from an SD memory card can be checked.



Fig. 1

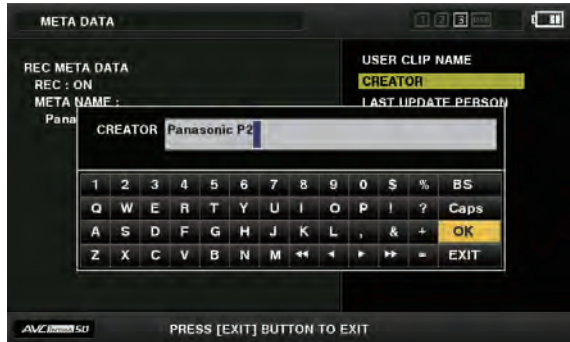

Fig. 2

- 1 Select [PROPERTY] in the main menu → [RECORDING SETUP] → [REC META DATA].  
The metadata list is displayed.
- 2 Use the control stick to move the cursor over the item to be checked, and press the control stick. (Fig. 1)  
Settings of the uploaded metadata can be checked.
- 3 While checking the settings for the metadata, use the control stick to move the cursor over the item that you want to change the setting, and press the control stick.
  - A software keyboard screen is displayed, allowing you to modify the setting. (Fig. 2)
  - While holding down the <SHIFT> button, press the control stick upward/downward to move the cursor to the first/last of the setting items.

Setting whether to record the uploaded metadata

Set [ON]/[OFF] in the main menu → [RECORDING SETUP] → [REC META DATA] → [RECORD]. [OFF] is set in the factory settings.

Selecting the [USER CLIP NAME] recording method

Select the [USER CLIP NAME] recording method from the two of [TYPE1] and [TYPE2] in the main menu → [RECORDING SETUP] → [REC META DATA] → [USER CLIP NAME].

■ [TYPE1] (factory settings)

Status of clip metadata	[USER CLIP NAME] to be recorded
When clip metadata has been loaded	Uploaded data

Status of clip metadata	[USER CLIP NAME] to be recorded
When no clip metadata has been loaded, or when setting disables recording of loaded clip metadata	Same as [GLOBAL CLIP ID]

■ [TYPE2]

Status of clip metadata	[USER CLIP NAME] to be recorded
When clip metadata has been loaded	Uploaded data + [COUNT] value*
When no clip metadata has been loaded, or when setting disables recording of loaded clip metadata	Same as [CLIP NAME]

\* The [COUNT] value is indicated as a four-digit number.

The [COUNT] value is incremented each time a new clip is generated, if the clip metadata has been loaded and [TYPE2] has been selected as the recording method.

The [COUNT] value can be reset using the following method.

When you select [PROPERTY] in the main menu → [RECORDING SETUP] → [REC META DATA] and then select [USER CLIP NAME], the following screen is displayed. Move the cursor over [COUNT RESET], and press the control stick to reset the [COUNT] value to 1.

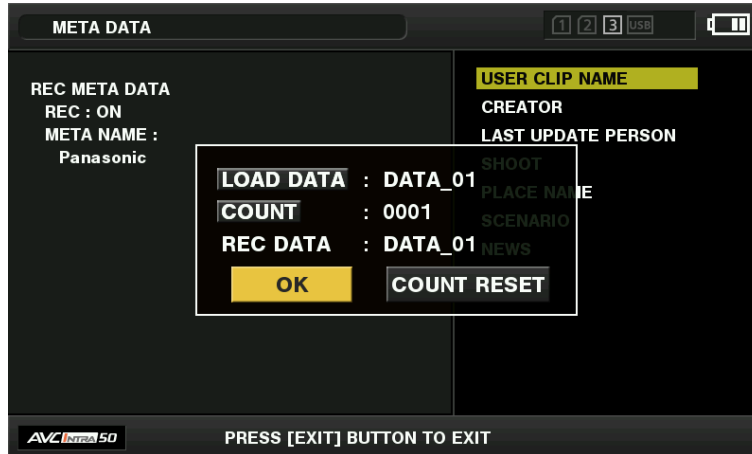

### Selecting the [CARD SERIAL] recording

When [ON] is selected in main menu → [RECORDING SETUP] → [REC META DATA] → [CARD SERIAL], the function that records the serial number of the P2 card as metadata (text memo without offset) is enabled.

### Initializing the metadata setting

Select [INITIALIZE] in the main menu → [RECORDING SETUP] → [REC META DATA] and press the control stick. Select [YES] when the confirmation screen is displayed.

The settings in the main menu → [RECORDING SETUP] → [REC META DATA] and later items, including loaded metadata, are initialized.

### Formatting a P2 card

**1** Select [FORMAT] in the main menu → [CLIP].

- Select the slot number where the P2 card to be formatted is inserted, and press the control stick.
- Select [EXIT] when you do not wish to format the card.

**2** Select [YES] using the control stick.

The selected P2 card is formatted.

**NOTE**

- Data deleted as a result of formatting cannot be restored. Always check the data before formatting.
- If the CPS password has been set, the confirmation message whether to select the encrypted format [CPS(ENCRYPT)] or normal format [NORMAL] is displayed when selecting a slot. When the encrypted format is selected, the microP2 memory card is encrypted.

### Formatting SD memory cards

SD memory cards can also be formatted in the thumbnail screen. With an SD memory card inserted into the camera, perform the following operation.

**1** Select [FORMAT] in the main menu → [CLIP].

- Select [SD CARD] and press the control stick.
- Select [EXIT] when you do not wish to format the card.

**2** Select [YES] using the control stick.

The SD memory card is formatted.

**NOTE**

- SD memory cards can also be formatted in the main menu → [CARD FUNCTIONS] → [FORMAT SD CARD]. For details, refer to “Formatting SD memory cards” (page 90).

- Data deleted as a result of formatting cannot be restored. Always check the data before formatting.

## Properties

Clip properties and P2 card status are displayed.

It is possible to edit and rewrite the recorded clip metadata while clip properties are displayed.

### Clip properties

Select [CLIP PROPERTY] in the main menu → [CLIP] → [PROPERTY].



#### 1 Clip information

Displays the indicators added to the clip and the number of added text memos.

The **T** mark will be displayed if the P2 card in which the clip is recorded is write-protected.

#### 2 Clip number



#### NOTE

- For clips that cannot be played back, the number is displayed in red.

#### 3 Thumbnail

#### 4 Clip information

Displays detailed information about the clip.

[CLIP NAME]	Displays clip names.
[START TC]	Displays the time code value at the start of the recording.
[START UB]	Displays the user bit value at the start of the recording.
[DATE]	Displays the date of the recording.
[TIME]	Displays the time at the start of recording.
[DURATION]	Displays the time length of the clip.
[V_FORMAT]	Displays the recording format of the clip.
[FRAME RATE]	Displays the frame rate for playback.
[REC RATE]	Displays the recording frame rate. For the clips recorded with variable frame rate compatible devices, the frame rate at the time of shooting is displayed.

#### 5 Clip metadata

The items for referencing clip properties (clip metadata) are displayed.

For details, refer to “Setting clip metadata” (page 114).

### Modifying recorded clip metadata

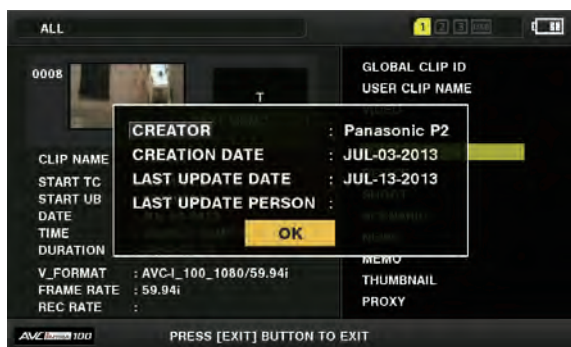

Fig. 1

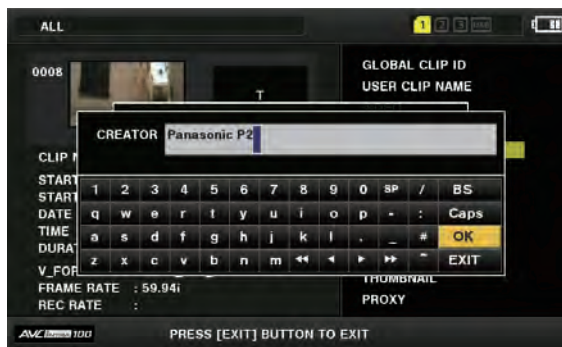

Fig. 2

**1** Display the metadata details window for the clip to be modified on the clip properties screen.

**2** Place the cursor on the item to be modified using the control stick. (Fig. 1)

The items of the metadata with the gray buttons in background can be modified.

**3 Press the control stick.**

Information about keyboard operation is the same as “Checking and modifying uploaded metadata” (page 115).

- The input window (soft keyboard) for modifying metadata is displayed. (Fig. 2)
- Enter characters with the keyboard to modify the metadata.

**4 Press the [OK] button on the keyboard.**

The modified metadata is written on the clip and the screen returns to the metadata details window.

**NOTE**

- To delete each item in [LOCATION] (shooting location data) of [SHOOT], the item cannot be deleted alone. By setting the [ALTITUDE] item to empty, other [LONGITUDE] and [LATITUDE] items are collectively deleted.
- Metadata of clips with **I** (incomplete clip indicator) cannot be repaired. Repair of metadata of clips recorded across multiple P2 cards must be performed after inserting all of the P2 cards.
- Any [MEMO] with 101 characters or more cannot be modified.

**Displaying P2 card status**

■ **P2 card status display settings**

You can select the P2 card status display from either remaining capacity or used capacity of the P2 card.



Fig. 1

**1 Press the <THUMBNAIL> button.**

The thumbnail screen appears on the viewfinder screen.

**2 Select [REMAIN] (remaining capacity) or [USED] (used capacity) in the main menu → [CLIP] → [PROPERTY] → [REMAIN SETUP]. (Fig. 1)**

■ **P2 card status display items**

[REMAIN]	Displays remaining capacity on the P2 card as the P2 card status display. (Factory setting)
[USED]	Displays used memory capacity on the P2 card as the P2 card status display.

**Contents of P2 card status display settings**

Select [CARD STATUS] in the main menu → [CLIP] → [PROPERTY].

■ **When [REMAIN] is selected**

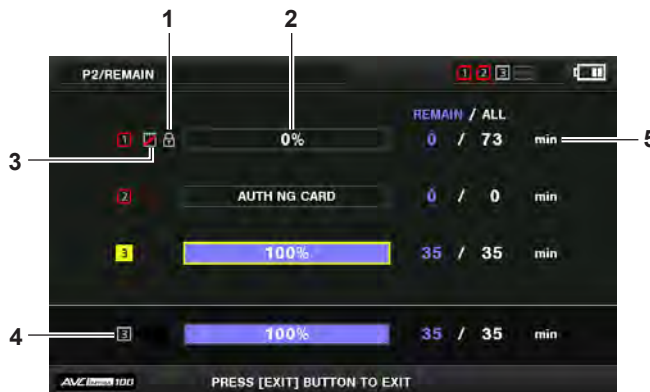



■ When [USED] is selected

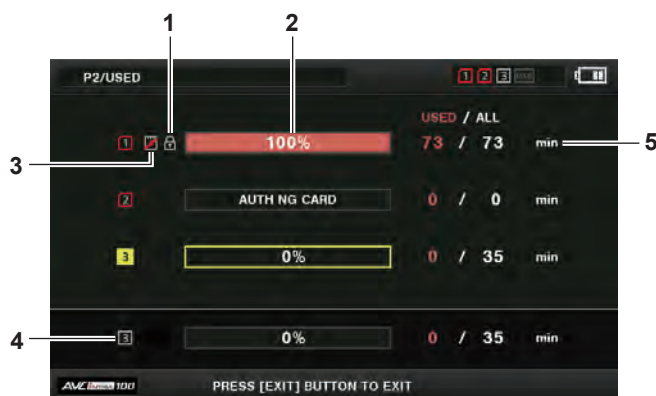

Fig. 1

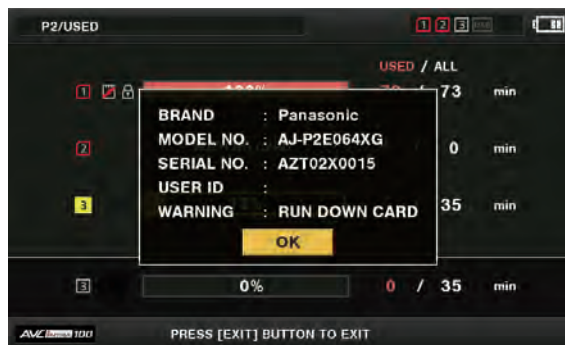

Fig. 2

1 Write-protected mark

The mark appears when the P2 card is write-protected.

2 P2 card status (remaining capacity)

The remaining memory capacity of the P2 card is shown as a bar graph and percentage. The bar graph indicator moves to the left as the remaining capacity decreases.

The following displays may also appear, depending on the card status.

[FORMAT ERROR!]	An unformatted P2 card is inserted.
[NOT SUPPORTED!]	An unsupported card is inserted.
[NO CARD]	No P2 card is inserted.
[AUTH NG CARD]	Indicates that the card is a microP2 memory card which cannot authenticate a CPS password.

Use the control stick to place the cursor on the P2 card where data to be accessed is saved and press the control stick to display detailed information on the P2 card. Specific information such as the serial number and the user ID can be checked. (Fig. 1)

When the maximum number of clips that can be recorded in the P2 card has been reached, [OVER MAX NUMBER CLIPS] is displayed in the P2 card detailed information showing that the upper limit has been reached.

3 Warning card mark

When P2 cards are the following status, the mark is displayed.

[RUN DOWN CARD]	The maximum number of overwrites on the P2 card has been exceeded.
[DIR ENTRY NG]	The directory structure on the P2 card is not supported.

The warning can be checked on the P2 card detailed information in “P2 card status (remaining capacity)” (page 119). (Fig. 2)

4 Total slot memory remaining capacity (or used capacity)

This displays the total remaining memory capacity (or used capacity) of the three slots. The available space of a write-protected P2 card is not included in the total available space.

5 P2 card remaining capacity (or used capacity) / total capacity

This displays the remaining capacity (or used capacity) / total capacity of the P2 card. Since only the figures in minutes are displayed, the remaining memory capacity (or used capacity) for each P2 card may not match the total capacity.

**Setting CPS password**

To set a CPS password, either load the password from the SD memory card or use the menu of the camera to enter the password. Only one CPS password can be set on the camera. Loading the CPS password again overwrites the previously saved password.

**Loading CPS password from SD memory card**

- 1 Download and install the latest P2 Viewer Plus into a computer.
- 2 With P2 Viewer Plus, generate a CPS password and write it to the SD memory card.
- 3 Load the CPS password file.

1) Start the camera, and insert the SD memory card into the SD card slot.

- 2) Open the thumbnail screen and select [LOAD] in the main menu → [CLIP] → [PROPERTY] → [CPS PASSWORD].  
The password file list is displayed.
- 3) Select the file to be used and press the control stick.
  - When loading of the CPS password has succeeded, the message [LOADING PASSWORD COMPLETED!] is displayed.
  - When loading of the CPS password has failed, a warning message is displayed. For an explanation of warnings, refer to “Warning system” (page 195).

 **NOTE**

- The CPS password file generated on the SD memory card is encrypted. If it is no longer used, format the SD memory card for security risk management.

**Setting CPS password using the menu of the camera**

**1 Open the thumbnail screen and select [SET] in the main menu → [CLIP] → [PROPERTY] → [CPS PASSWORD].**

The software keyboard to enter the CPS password is displayed.

**2 Enter the CPS password with the keyboard.**

Enter [PASSWORD] and [RETRY PASSWORD] for verification, and select [OK] to set the CPS password.

- When entry of the CPS password has succeeded, the message [SETTING PASSWORD COMPLETED!] is displayed.
- When entry of the CPS password has failed, the warning message is displayed. For warnings description, refer to “During thumbnail and menu operation” (page 196).

 **NOTE**

- Up to 16 characters can be input.
- The entered password cannot be displayed on the device. Do not forget the password.

**Deleting CPS password**

When the CPS function is no longer used, delete the CPS password.

**1 Open the thumbnail screen and select [DELETE] in the main menu → [CLIP] → [PROPERTY] → [CPS PASSWORD].**

[DELETING PASSWORD COMPLETED!] is displayed and the CPS password is deleted.

 **NOTE**

- When the CPS password is deleted, automatic authentication of the encrypted microP2 memory card and encryption format function are disabled.

**Manual CPS authentication**

An encrypted microP2 memory card is authenticated on the camera automatically, and can be used only if the authentication has succeeded.

Authentication fails if the CPS password set to device and the CPS password set to microP2 memory card differ. To temporarily use a microP2 memory card whose authentication has failed, manually enter the CPS password authorized for the microP2 memory card in accordance with the following procedures. If the code matches, you can use the card.

**1 Confirm that authentication has failed.**

- 1) Open the thumbnail screen and select [CARD STATUS] in the main menu → [CLIP] → [PROPERTY].

For the card whose authentication has failed, the slot number frame at the top right of the screen turns red, and [AUTH NG CARD] is displayed on the remaining capacity bar. Select the card by pushing the control stick upward/downward.

**2 Perform manual authentication.**

- 1) On the card status screen, select [AUTHENTICATE] in the main menu → [CLIP].  
The software keyboard to enter the CPS password is displayed.
- 2) Enter the password set on the microP2 memory card and select [OK].
  - When entry of the CPS password has succeeded, the message [AUTHENTICATED SUCCESSFULLY!] is displayed.
  - When entry of the CPS password has failed, the warning message (page 196) is displayed.

 **NOTE**

- Manual authentication is valid temporarily. If the target microP2 card is removed or power is turned off, the CPS password set manually is disabled.
- Visit the following website for conditions where manual authentication is valid.  
<http://pro-av.panasonic.net/>
- The encrypted microP2 memory card is not recognized on the SD card slot in a computer.
- If the card is unable to be recognized, authenticate with the correct password, or format the card and use it as recording media, or remove it from the camera. Do not perform any operation other than manual authentication and formatting with the failed card inserted.

**SD memory card status display**

The status display enables confirmation of the SD memory card format condition, available memory space, etc.

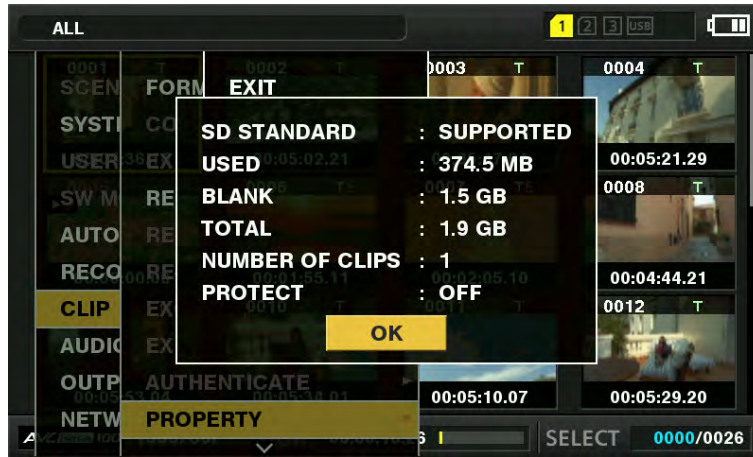

Select [SD CARD] in the main menu → [CLIP] → [PROPERTY]. The same information can be displayed from the main menu → [CARD FUNCTIONS] → [SD CARD PROPERTY].

<b>[SD STANDARD]</b>	Indicates whether an SD memory card is formatted according to the SD/SDHC/SDXC standard. <ul style="list-style-type: none"> <li>• [SUPPORTED]: Complies with SD/SDHC/SDXC standards</li> <li>• [NOT SUPPORTED]: Does not comply with SD/SDHC/SDXC standards</li> </ul>
<b>[USED]</b>	Used capacity (bytes)
<b>[BLANK]</b>	Available space (bytes)
<b>[TOTAL]</b>	Total capacity (bytes)
<b>[PROXY REM]</b>	Remaining capacity for proxy recording
<b>[NUMBER OF CLIPS]</b>	The number of clips on an SD memory card when clips have been copied to an SD memory card
<b>[PROTECT]</b>	Write-protected status

## Chapter 6 **Menu Operations**

---

This chapter describes how to operate the camera menus, the structure, and details of the setting menu.



## Setting menu structure

### Menu types and how to open them

Menu type	Use	How to open
[USER MENU]	In the main menu → [USER MENU SEL], you can select the desired items and pages and register to [USER MENU]. You can select them depending on the purpose or frequency of use to make a unique menu structure. For details, refer to “Setting [USER MENU]” (page 125).	Displayed by pressing the <MENU> button.
Main menu	You can set all items in the setting menu. The main menu has a structure of categorized layers according to intended use and setting frequency.	Displayed by pressing and holding the <MENU> button for three seconds or more.
[OPTION MENU]	Menu items are prepared to take into account additional functions in the future. Please consult your vendor for more details.	Displayed by pressing the <MENU> button while pressing and holding the <LCD BACKLIGHT> button.

### Main menu structure

[SCENE FILE]	Configures the settings for scene files. This item is used to configure detailed image quality settings of the camera images, to select scene files, and to configure the settings for reading/writing of scene file data to the internal memory. This menu item cannot be set when the thumbnail screen is displayed.
[SYSTEM MODE]	Configures the settings for the recording format of video and audio.
[USER SW]	Sets the functions to be assigned to the USER buttons (USER1 to USER8).
[SW MODE]	Configures the operations of each mode when switched the mode using each switch. This menu item cannot be set when the thumbnail screen is displayed.
[AUTO SW]	Configures the settings for the auto mode. Auto iris, auto gain control, auto tracking white balance, and auto focus functions can be set separately. This menu item cannot be set when the thumbnail screen is displayed.
[RECORDING SETUP]	Configures various settings when performing recording and playback. Set the system frequency, the number of lines, recording format, and recording method.
[CLIP]	Used when performing various tasks, such as playing back, deleting, and copying clips, and editing metadata, while checking the thumbnail of the clips displayed in the viewfinder or LCD monitor. This menu item is enabled when the thumbnail screen is displayed. Clip operations such as [DELETE] or [COPY] are enabled when the target thumbnail is selected. Some items are displayed only in specific situations such as in USB host mode or on the explorer screen.
[AUDIO SETUP]	Configures the settings for audio input/output.
[OUTPUT SEL]	Configures the settings for video output from the <SDI OUT>, <HDMI OUT>, <GENLOCK IN/VIDEO OUT>, and <TC IN/OUT> terminals.
[NETWORK SETUP]	Configures the settings for network.
[DISPLAY SETUP]	Configures the settings for the details to be displayed in the viewfinder or LCD monitor. This menu item cannot be set when the thumbnail screen is displayed.
[CARD FUNCTIONS]	Configures the settings for reading/writing of scene files and user files to SD memory cards.
[OTHER FUNCTIONS]	Configures the settings for reading/writing of user files to internal memory and initialization, and the camera settings.
[MAINTENANCE]	Used for performing maintenance of the camera. This item is used when updating the firmware version of the camera.
[DIAGNOSTIC]	Displays the firmware version, product name, serial number, and energized time of the camera.
[USER MENU SEL]	Sets the items to be displayed in [USER MENU].

# Setting menu display

## Setting menu basic operations

You can change camera settings using the setting menu according to the shooting scene and recording details.

The menu is divided into the main menu, submenu, and setting item menu.

Set data are written and saved in the internal memory of the camera.

Menu items can be selected by control stick operation or the <SEL/PUSH SET> dial button operation.

This section describes main menu operations. Main menu operation is the same as the other menus except when opening the menu screen.

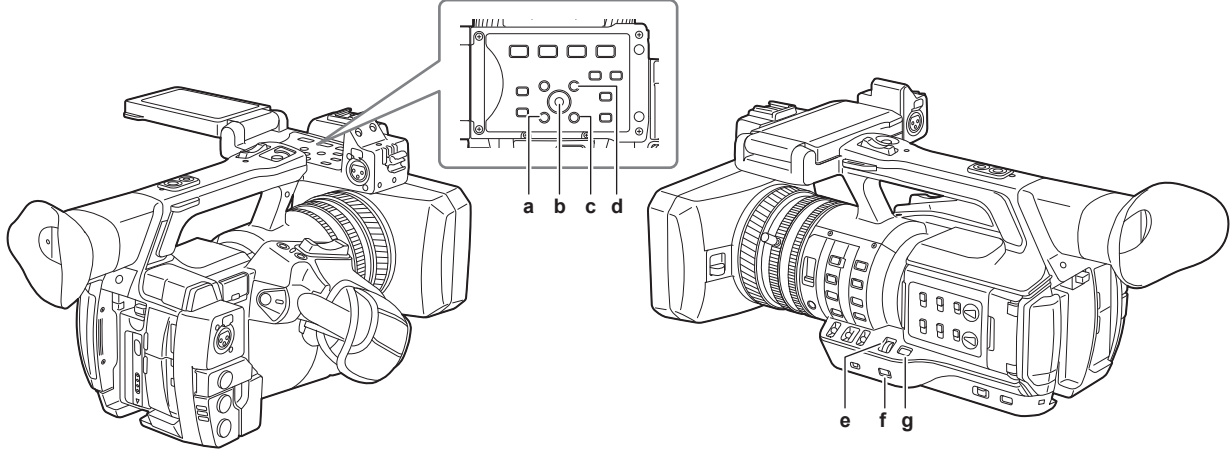

- a: <EXIT> button
- b: Control stick
- c: <MENU> button (Operation panel of the LCD monitor)
- d: <SHIFT> button
- e: <SEL/PUSH SET> dial button
- f: <MENU> button
- g: <MODE/MENU CANCEL> button

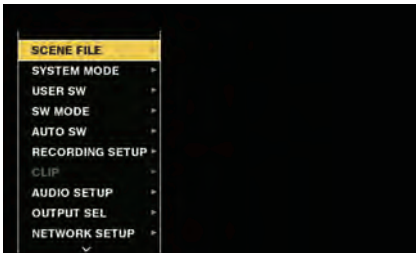

Fig. 1

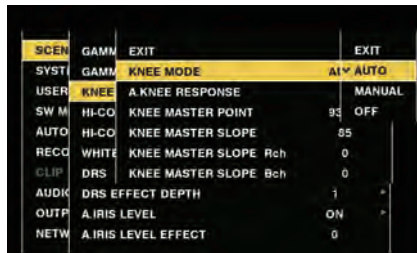

Fig. 2

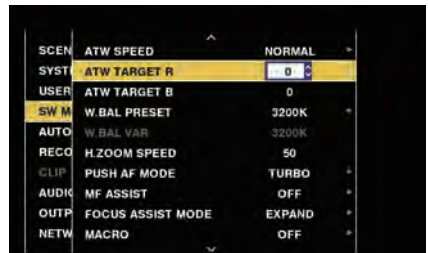

Fig. 3

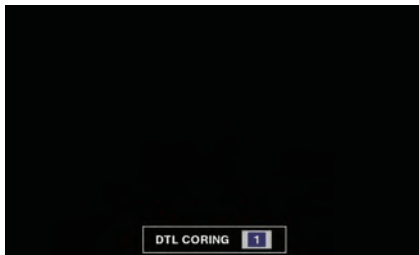

Fig. 4

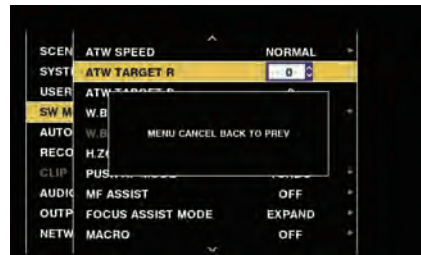

Fig. 5

### ■ Selecting menu item using control stick

#### 1 Press and hold the <MENU> button for three seconds or more when not recording.

- The main menu screen is displayed in the viewfinder and on the LCD monitor.

#### 2 Press the control stick upward/downward to place the cursor on the desired menu item. (Fig. 1)

- The cursor moves up/down by pushing the control stick upward/downward.
- If there is a menu in the next level, [▶] is displayed in the menu items.  
Pressing the control stick to the right or pressing the control stick opens the lower-level menus. (Fig. 2)
- Pressing the control stick to the left or pressing the <EXIT> button returns the upper level of menu.

#### 3 Press the control stick.

- The confirmation screen is displayed depending on the menu item.  
Press the control stick upward/downward/to the left/to the right to select the operation, and then press the control stick.  
A checkmark is placed in front of the set item.
- In some menus, a screen for setting value is displayed on the menu screen (Fig. 3) or at the bottom of the screen (Fig. 4).

#### 4 Press the <MENU> button to close the menu.

- This brings you back automatically to the previous screen depending on the menu item.

#### ■ Selecting menu item with the <SEL/PUSH SET> dial button

#### 1 Press and hold the <MENU> button for three seconds or more when not recording.

- The main menu screen is displayed in the viewfinder and on the LCD monitor.

#### 2 Turn the <SEL/PUSH SET> dial button to place the cursor on the desired menu item. (Fig. 1)

- The cursor moves up/down by turning the <SEL/PUSH SET> dial button upward/downward.
- If there is a menu in the next level, [▶] is displayed in the menu items.  
Pressing the <SEL/PUSH SET> dial button opens the lower-level menus. (Fig. 2)
- You can go back to the upper levels by pressing the <EXIT> button or by placing the cursor on the topmost line ([EXIT]) then pressing the <SEL/PUSH SET> dial button.

#### 3 Press the <SEL/PUSH SET> dial button.

- The confirmation screen is displayed depending on the menu item.  
Turn the <SEL/PUSH SET> dial button to select the operation, and then press the <SEL/PUSH SET> dial button.  
A checkmark is placed in front of the set item.
- In some menus, a screen for setting value is displayed on the menu screen (Fig. 3) or at the bottom of the screen (Fig. 4).

#### 4 Press the <MENU> button to close the menu.

- This brings you back automatically to the previous screen depending on the menu item.

#### ■ Performing cancellation while setting

#### 1 Press the <MODE/MENU CANCEL> button. Alternatively, press the <EXIT> button while holding down the <SHIFT> button.

[MENU CANCEL BACK TO PREV] is displayed. (Fig. 5)

#### 2 Press the <MODE/MENU CANCEL> button again. Alternatively, press the <EXIT> button while holding down the <SHIFT> button.

The changed value returns to the value before changing.

#### NOTE

- You will need to restart the camera if the number of lines and frequency setting of the system change.

## Setting [USER MENU]

#### 1 Select the main menu → [USER MENU SEL].

#### 2 Select and display various items according to level.

#### 3 Put checkmarks [✓] on the items to be displayed in [USER MENU].

You can select menu items in each item or page. You can select up to 64 items.

Selected items are displayed on the main menu page or item in order.

[USER MENU] settings can also be saved on or loaded from the camera and the SD memory card at the same time as a user file.

## Setting menu initialization

The values set in the setting menu are saved in the user file and scene file. Both the user file and scene file can be initialized to the factory settings.

### Initializing user file (all items except for the scene file)

#### 1 Select [INITIALIZE] in the main menu → [OTHER FUNCTIONS] → [USER FILE].

### Initializing selected scene file

#### 1 Select the scene file to initialize in the main menu → [SCENE FILE] → [FILE SELECT].

#### 2 Select [INITIALIZE] in the main menu → [SCENE FILE] → [LOAD/SAVE/INITIALIZE].

**Initializing user file and all scene files simultaneously**

- 1** Select the main menu → [OTHER FUNCTIONS] → [MENU INITIALIZE].
- 2** Select [YES].

## Menu list

### [SCENE FILE]

Configure the settings regarding scene files.

This menu is used to set fine image quality settings of the camera images, select scene files, and read/write scene file data to the internal memory.

These menu items cannot be set when the thumbnail screen is displayed.

Item	Description of settings
[FILE SELECT]	Selects the scene file (1 to 6). <b>[F1:]</b> , <b>[F2:FLUO.]</b> , <b>[F3:SPARK]</b> , <b>[F4:B-STR]</b> , <b>[F5:CINE V]</b> , <b>[F6:CINE D]</b> • Factory setting: [F1:]
[NAME EDIT]	Edits the name of the scene file selected in the scene file menu. (Maximum of six characters)
[LOAD/SAVE/INITIALIZE]	Loads/saves/initializes the setting values allocated on the current scene file number (any one from 1 to 6). <b>[LOAD]</b> : Selects and loads a scene file saved in the camera memory. <b>[SAVE]</b> : Specifies a title and file number for the current setting values and saves them as a scene file in the camera memory. <b>[INITIALIZE]</b> : Initializes the selected scene files (1 to 6) to the factory settings.
[VFR]	Sets permission/prohibition of the variable frame rate (VFR). <b>[ON]</b> , <b>[OFF]</b> • Factory setting: [OFF]
[FRAME RATE]	Switches the shooting interval and exposure time when [VFR] is [ON]. When [SYSTEM MODE] = 59.94 Hz: <b>[60fps]</b> , <b>[54fps]</b> , <b>[48fps]</b> , <b>[44fps]</b> , <b>[40fps]</b> , <b>[36fps]</b> , <b>[34fps]</b> , <b>[32fps]</b> , <b>[30fps]</b> , <b>[28fps]</b> , <b>[27fps]</b> , <b>[26fps]</b> , <b>[25fps]</b> , <b>[24fps]</b> , <b>[22fps]</b> , <b>[21fps]</b> , <b>[20fps]</b> , <b>[18fps]</b> , <b>[15fps]</b> , <b>[12fps]</b> , <b>[9fps]</b> , <b>[6fps]</b> , <b>[4fps]</b> , <b>[2fps]</b> , <b>[1fps]</b> When [SYSTEM MODE] = 50 Hz: <b>[50fps]</b> , <b>[48fps]</b> , <b>[45fps]</b> , <b>[42fps]</b> , <b>[37fps]</b> , <b>[34fps]</b> , <b>[32fps]</b> , <b>[30fps]</b> , <b>[28fps]</b> , <b>[27fps]</b> , <b>[26fps]</b> , <b>[25fps]</b> , <b>[24fps]</b> , <b>[23fps]</b> , <b>[22fps]</b> , <b>[21fps]</b> , <b>[20fps]</b> , <b>[18fps]</b> , <b>[15fps]</b> , <b>[12fps]</b> , <b>[9fps]</b> , <b>[6fps]</b> , <b>[4fps]</b> , <b>[2fps]</b> , <b>[1fps]</b> • Factory setting: [24fps] (when [SYSTEM MODE] = 59.94 Hz), [25fps] (when [SYSTEM MODE] = 50 Hz)
[SYNC SCAN TYPE]	Switches the synchro scan display settings. <b>[sec]</b> : Displays in time. <b>[deg]</b> : Displays at shutter open angle. • Factory setting: [sec]
[SYNCHRO SCAN]	Displays the speed of the synchro scan shutter that is used when shooting video for television etc. When [SYNC SCAN TYPE] = [sec], and [SYSTEM MODE] = 59.94 Hz: • 60i/60p: <b>[1/60.0]...[1/249.8]</b> • 30P: <b>[1/30.0]...[1/249.8]</b> • 24P: <b>[1/24.0]...[1/249.8]</b> When [SYNC SCAN TYPE] = [sec], and [SYSTEM MODE] = 50 Hz: • 50i/50P: <b>[1/50.0]...[1/250.0]</b> • 25P: <b>[1/25.0]...[1/250.0]</b> When [SYNC SCAN TYPE] = [deg] (in 0.5 d steps, angle display): <b>[3.0d]...[360.0d]</b> • Factory setting: [1/60.0] (when [SYNC SCAN TYPE] = [sec], and [SYSTEM MODE] = 59.94 Hz)
[MASTER DTL]	Sets the level of the detail effect of the whole part. <b>[-31]...[31]</b> • Factory setting: [0]
[DTL CORING]	Sets the level of signal (including noise) that does not activate the detail effect. <b>[0]...[60]</b> • Factory setting: [1]
[DETAIL SETTING]	[DETAIL] Sets [ON]/[OFF] of the detail function. <b>[ON]</b> , <b>[OFF]</b> • Factory setting: [ON]
	[V.DTL LEVEL] Sets the intensity of the detail level in the vertical direction. <b>[-7]...[7]</b> • Factory setting: [0]
	[H.DTL FREQ.] Sets the thickness of the detail level in the horizontal direction. <b>[-7]...[7]</b> • Factory setting: [0]
	[V. DTL FREQ.] Sets the thickness of the detail level in the vertical direction. <b>[0]...[2]</b> • Factory setting: [1]
	[LEVEL DEPEND.] When the detail of luminosity signal is emphasized, details in the darker parts are compressed. Details of bright areas are also compressed more when the value set for [LEVEL DEPEND.] is larger. <b>[-7]...[7]</b> • Factory setting: [0]
	[KNEE APE LVL] Sets the detail level of high luminosity areas (high-brightness areas). <b>[OFF]</b> , <b>[1]...[5]</b> • Factory setting: [2]
	[DTL GAIN(+)] Sets the detail level of + direction (to make brighter). <b>[-31]...[31]</b> • Factory setting: [0]
	[DTL GAIN(-)] Sets the detail level of - direction (to make darker). <b>[-31]...[31]</b> • Factory setting: [0]

## Chapter 6 Menu Operations — Menu list

Item	Description of settings																
[SKIN TONE DTL A]	<p>Selects the skin tone table that will display the skin tone detail. Create the skin tone table with [DETECT TABLE]. You can shoot smoother skin tones by displaying the skin tone detail. [SKIN TONE DTL A] can be used alone or used in combination with [SKIN TONE DTL B] and [SKIN TONE DTL C].</p> <p><b>[ON], [OFF]</b> • Factory setting: [OFF]</p>																
[SKIN TONE DTL B]	<p>Selects the skin tone table that will display the skin tone detail. Create the skin tone table with [DETECT TABLE]. You can shoot smoother skin tones by displaying the skin tone detail. [SKIN TONE DTL B] can be used alone or used in combination with [SKIN TONE DTL A] and [SKIN TONE DTL C].</p> <p><b>[ON], [OFF]</b> • Factory setting: [OFF]</p>																
[SKIN TONE DTL C]	<p>Selects the skin tone table that will display the skin tone detail. Create the skin tone table with [DETECT TABLE]. You can shoot smoother skin tones by displaying the skin tone detail. [SKIN TONE DTL C] can be used alone or used in combination with [SKIN TONE DTL A] and [SKIN TONE DTL B].</p> <p><b>[ON], [OFF]</b> • Factory setting: [OFF]</p>																
[SKIN TONE ZEBRA]	<p>Set to display a zebra pattern in the skin tone area displayed in the viewfinder screen. The zebra pattern is displayed when this item is set to [ON] and [SKIN TONE DTL A]/[SKIN TONE DTL B]/[SKIN TONE DTL C] is activated. The zebra pattern displays the area selected in [SKIN TONE DTL SETTING].</p> <p><b>[ON], [OFF]</b> • Factory setting: [ON]</p>																
[SKIN TONE DTL SETTING]	<table border="1" style="width: 100%; border-collapse: collapse;"> <tr> <td style="width: 20%;">[DETECT TABLE]</td> <td>Selects the skin tone table of the subject that displays the skin tone detail. <b>[A], [B], [C]</b> • Factory setting: [A]</td> </tr> <tr> <td>[SKIN TONE GET]</td> <td>Obtains the color information of [A], [B], or [C] selected in [DETECT TABLE] from near the center marker. If executed, data from [I CENTER] to [Q PHASE] are automatically obtained. The obtained data becomes the table data of [A], [B], or [C] selected in [DETECT TABLE]. Multiple color information for [A], [B], and [C] cannot be obtained simultaneously.</td> </tr> <tr> <td>[SKIN DTL EFFECT]</td> <td>Sets the effective level of the skin tone detail. <b>[0]...[31]</b> • Factory setting: [16]</td> </tr> <tr> <td>[I CENTER]</td> <td>Sets the center position of the upper I axis (setting the area that displays the skin tone). <b>[0]...[255]</b> • Factory setting: [35]</td> </tr> <tr> <td>[I WIDTH]</td> <td>Sets the width of the area that displays the skin tone of the upper I axis that focus on [I CENTER]. <b>[0]...[255]</b> • Factory setting: [55]</td> </tr> <tr> <td>[Q WIDTH]</td> <td>Sets the width of the area that displays the skin tone of the upper Q axis that focus on [I CENTER]. <b>[0]...[90]</b> • Factory setting: [10]</td> </tr> <tr> <td>[Q PHASE]</td> <td>Sets the phase of the area that displays the skin tone regarding to the Q axis. <b>[-180]...[179]</b> • Factory setting: [0]</td> </tr> </table>	[DETECT TABLE]	Selects the skin tone table of the subject that displays the skin tone detail. <b>[A], [B], [C]</b> • Factory setting: [A]	[SKIN TONE GET]	Obtains the color information of [A], [B], or [C] selected in [DETECT TABLE] from near the center marker. If executed, data from [I CENTER] to [Q PHASE] are automatically obtained. The obtained data becomes the table data of [A], [B], or [C] selected in [DETECT TABLE]. Multiple color information for [A], [B], and [C] cannot be obtained simultaneously.	[SKIN DTL EFFECT]	Sets the effective level of the skin tone detail. <b>[0]...[31]</b> • Factory setting: [16]	[I CENTER]	Sets the center position of the upper I axis (setting the area that displays the skin tone). <b>[0]...[255]</b> • Factory setting: [35]	[I WIDTH]	Sets the width of the area that displays the skin tone of the upper I axis that focus on [I CENTER]. <b>[0]...[255]</b> • Factory setting: [55]	[Q WIDTH]	Sets the width of the area that displays the skin tone of the upper Q axis that focus on [I CENTER]. <b>[0]...[90]</b> • Factory setting: [10]	[Q PHASE]	Sets the phase of the area that displays the skin tone regarding to the Q axis. <b>[-180]...[179]</b> • Factory setting: [0]		
[DETECT TABLE]	Selects the skin tone table of the subject that displays the skin tone detail. <b>[A], [B], [C]</b> • Factory setting: [A]																
[SKIN TONE GET]	Obtains the color information of [A], [B], or [C] selected in [DETECT TABLE] from near the center marker. If executed, data from [I CENTER] to [Q PHASE] are automatically obtained. The obtained data becomes the table data of [A], [B], or [C] selected in [DETECT TABLE]. Multiple color information for [A], [B], and [C] cannot be obtained simultaneously.																
[SKIN DTL EFFECT]	Sets the effective level of the skin tone detail. <b>[0]...[31]</b> • Factory setting: [16]																
[I CENTER]	Sets the center position of the upper I axis (setting the area that displays the skin tone). <b>[0]...[255]</b> • Factory setting: [35]																
[I WIDTH]	Sets the width of the area that displays the skin tone of the upper I axis that focus on [I CENTER]. <b>[0]...[255]</b> • Factory setting: [55]																
[Q WIDTH]	Sets the width of the area that displays the skin tone of the upper Q axis that focus on [I CENTER]. <b>[0]...[90]</b> • Factory setting: [10]																
[Q PHASE]	Sets the phase of the area that displays the skin tone regarding to the Q axis. <b>[-180]...[179]</b> • Factory setting: [0]																
[RB GAIN CONTROL SETTING]	<table border="1" style="width: 100%; border-collapse: collapse;"> <tr> <td style="width: 20%;">[R GAIN AWB PRE]</td> <td>Sets the Rch gain when the &lt;WHITE BAL&gt; switch is on &lt;PRST&gt;. <b>[-200]...[200]</b> • Factory setting: [0]</td> </tr> <tr> <td>[B GAIN AWB PRE]</td> <td>Sets the Bch gain when the &lt;WHITE BAL&gt; switch is on &lt;PRST&gt;. <b>[-200]...[200]</b> • Factory setting: [0]</td> </tr> <tr> <td>[R GAIN AWB A]</td> <td>Sets the Rch gain when the &lt;WHITE BAL&gt; switch is on &lt;A&gt;. <b>[-200]...[200]</b> • Factory setting: [0]</td> </tr> <tr> <td>[B GAIN AWB A]</td> <td>Sets the Bch gain when the &lt;WHITE BAL&gt; switch is on &lt;A&gt;. <b>[-200]...[200]</b> • Factory setting: [0]</td> </tr> <tr> <td>[R GAIN AWB B]</td> <td>Sets the Rch gain when the &lt;WHITE BAL&gt; switch is on &lt;B&gt;. <b>[-200]...[200]</b> • Factory setting: [0]</td> </tr> <tr> <td>[B GAIN AWB B]</td> <td>Sets the Bch gain when the &lt;WHITE BAL&gt; switch is on &lt;B&gt;. <b>[-200]...[200]</b> • Factory setting: [0]</td> </tr> <tr> <td>[AWB A GAIN OFFSET]</td> <td>Sets the Rch gain and Bch gain when performing automatic white balance after the &lt;WHITE BAL&gt; switch is on &lt;A&gt;. <b>[ON]:</b> Keeps the values set in [R GAIN AWB A] and [B GAIN AWB A]. <b>[OFF]:</b> Sets the value of Rch gain and Bch gain to [0]. • Factory setting: [OFF]</td> </tr> <tr> <td>[AWB B GAIN OFFSET]</td> <td>Sets the Rch gain and Bch gain when performing automatic white balance after the &lt;WHITE BAL&gt; switch is on &lt;B&gt;. <b>[ON]:</b> Keeps the values set in [R GAIN AWB B] and [B GAIN AWB B]. <b>[OFF]:</b> Sets the value of Rch gain and Bch gain to [0]. • Factory setting: [OFF]</td> </tr> </table>	[R GAIN AWB PRE]	Sets the Rch gain when the <WHITE BAL> switch is on <PRST>. <b>[-200]...[200]</b> • Factory setting: [0]	[B GAIN AWB PRE]	Sets the Bch gain when the <WHITE BAL> switch is on <PRST>. <b>[-200]...[200]</b> • Factory setting: [0]	[R GAIN AWB A]	Sets the Rch gain when the <WHITE BAL> switch is on <A>. <b>[-200]...[200]</b> • Factory setting: [0]	[B GAIN AWB A]	Sets the Bch gain when the <WHITE BAL> switch is on <A>. <b>[-200]...[200]</b> • Factory setting: [0]	[R GAIN AWB B]	Sets the Rch gain when the <WHITE BAL> switch is on <B>. <b>[-200]...[200]</b> • Factory setting: [0]	[B GAIN AWB B]	Sets the Bch gain when the <WHITE BAL> switch is on <B>. <b>[-200]...[200]</b> • Factory setting: [0]	[AWB A GAIN OFFSET]	Sets the Rch gain and Bch gain when performing automatic white balance after the <WHITE BAL> switch is on <A>. <b>[ON]:</b> Keeps the values set in [R GAIN AWB A] and [B GAIN AWB A]. <b>[OFF]:</b> Sets the value of Rch gain and Bch gain to [0]. • Factory setting: [OFF]	[AWB B GAIN OFFSET]	Sets the Rch gain and Bch gain when performing automatic white balance after the <WHITE BAL> switch is on <B>. <b>[ON]:</b> Keeps the values set in [R GAIN AWB B] and [B GAIN AWB B]. <b>[OFF]:</b> Sets the value of Rch gain and Bch gain to [0]. • Factory setting: [OFF]
[R GAIN AWB PRE]	Sets the Rch gain when the <WHITE BAL> switch is on <PRST>. <b>[-200]...[200]</b> • Factory setting: [0]																
[B GAIN AWB PRE]	Sets the Bch gain when the <WHITE BAL> switch is on <PRST>. <b>[-200]...[200]</b> • Factory setting: [0]																
[R GAIN AWB A]	Sets the Rch gain when the <WHITE BAL> switch is on <A>. <b>[-200]...[200]</b> • Factory setting: [0]																
[B GAIN AWB A]	Sets the Bch gain when the <WHITE BAL> switch is on <A>. <b>[-200]...[200]</b> • Factory setting: [0]																
[R GAIN AWB B]	Sets the Rch gain when the <WHITE BAL> switch is on <B>. <b>[-200]...[200]</b> • Factory setting: [0]																
[B GAIN AWB B]	Sets the Bch gain when the <WHITE BAL> switch is on <B>. <b>[-200]...[200]</b> • Factory setting: [0]																
[AWB A GAIN OFFSET]	Sets the Rch gain and Bch gain when performing automatic white balance after the <WHITE BAL> switch is on <A>. <b>[ON]:</b> Keeps the values set in [R GAIN AWB A] and [B GAIN AWB A]. <b>[OFF]:</b> Sets the value of Rch gain and Bch gain to [0]. • Factory setting: [OFF]																
[AWB B GAIN OFFSET]	Sets the Rch gain and Bch gain when performing automatic white balance after the <WHITE BAL> switch is on <B>. <b>[ON]:</b> Keeps the values set in [R GAIN AWB B] and [B GAIN AWB B]. <b>[OFF]:</b> Sets the value of Rch gain and Bch gain to [0]. • Factory setting: [OFF]																

## Chapter 6 Menu Operations — Menu list

Item	Description of settings	
[COLOR TEMP Ach SETTING]	[COLOR TEMP]	Displays the color temperature when the <WHITE BAL> switch is at the <A> position and automatic white balance is working, or when it is preset. Also, in automatic white balance operation, the color temperature can be changed by changing the output balance of Rch and Bch. <b>[2000K]...[15000K]</b> • Factory setting: [3200K]
	[R Gain]	Displays the Rch output when the <WHITE BAL> switch is at the <A> position and automatic white balance is working, or when it is preset. Also, in automatic white balance operation, the color can be changed on the Rch axis by changing the output of Rch. <b>[-400]...[400]</b> • Factory setting: [0]
	[B Gain]	Displays the Bch output when the <WHITE BAL> switch is at the <A> position and automatic white balance is working, or when it is preset. Also, in automatic white balance operation, the color can be changed on the Bch axis by changing the output of Bch. <b>[-400]...[400]</b> • Factory setting: [0]
	[G AXIS]	Displays the G axis output when the <WHITE BAL> switch is at the <A> position and automatic white balance is working, or when it is preset. Also, in automatic white balance operation, the color can be changed on the G axis by changing the output of Rch/Bch. <b>[-400]...[400]</b> • Factory setting: [0]
[COLOR TEMP Bch SETTING]	[COLOR TEMP]	Displays the color temperature when the <WHITE BAL> switch is at the <B> position and automatic white balance is working, or when it is preset. Also, in automatic white balance operation, the color temperature can be changed by changing the output balance of Rch and Bch. <b>[2000K]...[15000K]</b> • Factory setting: [3200K]
	[R Gain]	Displays the Rch output when the <WHITE BAL> switch is at the <B> position and automatic white balance is working, or when it is preset. Also, in automatic white balance operation, the color can be changed on the Rch axis by changing the output of Rch. <b>[-400]...[400]</b> • Factory setting: [0]
	[B Gain]	Displays the Bch output when the <WHITE BAL> switch is at the <B> position and automatic white balance is working, or when it is preset. Also, in automatic white balance operation, the color can be changed on the Bch axis by changing the output of Bch. <b>[-400]...[400]</b> • Factory setting: [0]
	[G AXIS]	Displays the G axis output when the <WHITE BAL> switch is at the <B> position and automatic white balance is working, or when it is preset. Also, in automatic white balance operation, the color can be changed on the G axis by changing the output of Rch/Bch. <b>[-400]...[400]</b> • Factory setting: [0]
[CHROMA LEVEL]	Sets the chroma level of P <sub>R</sub> and P <sub>B</sub> signals. <b>[-99%]...[40%], [OFF]</b> • Factory setting: [0%]	
[CHROMA PHASE]	Finely adjusts the chroma phase of the P <sub>R</sub> signal and P <sub>B</sub> signal. <b>[-31]...[31]</b> • Factory setting: [0]	
[MATRIX]	Selects the matrix table to display the color for shooting. <b>[NORM1]</b> : Displays the color suitable for shooting outdoors of under a halogen lamp. <b>[NORM2]</b> : Displays more vivid color than [NORM1]. <b>[FLUO.]</b> : Displays the color suitable for shooting indoors under fluorescent light. <b>[CINELIKE]</b> : Displays the color suitable for shooting cinematic video. • Factory setting: [NORM1]	
[MATRIX SETTING]	[MATRIX R-G]	Adjusts the linear matrix. (Red - Green) <b>[-63]...[63]</b> • Factory setting: [0]
	[MATRIX R-B]	Adjusts the linear matrix. (Red - Blue) <b>[-63]...[63]</b> • Factory setting: [0]
	[MATRIX G-R]	Adjusts the linear matrix. (Green - Red) <b>[-63]...[63]</b> • Factory setting: [0]
	[MATRIX G-B]	Adjusts the linear matrix. (Green - Blue) <b>[-63]...[63]</b> • Factory setting: [0]
	[MATRIX B-R]	Adjusts the linear matrix. (Blue - Red) <b>[-63]...[63]</b> • Factory setting: [0]
	[MATRIX B-G]	Adjusts the linear matrix. (Blue - Green) <b>[-63]...[63]</b> • Factory setting: [0]
[COLOR CORRECTION SETTING]	[R (SAT)]	Corrects red color saturation. <b>[-63]...[63]</b> • Factory setting: [0]
	[R (PHASE)]	Corrects the red hue. <b>[-63]...[63]</b> • Factory setting: [0]

## Chapter 6 Menu Operations — Menu list

Item	Description of settings
[R-R-Mg (SAT)]	Corrects the color saturation between red and "colors between red and magenta". [-63]...[63] • Factory setting: [0]
[R-R-Mg (PHASE)]	Corrects the hue between red and "colors between red and magenta". [-63]...[63] • Factory setting: [0]
[R-Mg (SAT)]	Corrects the color saturation between red and magenta. [-63]...[63] • Factory setting: [0]
[R-Mg (PHASE)]	Corrects the hue between red and magenta. [-63]...[63] • Factory setting: [0]
[Mg (SAT)]	Corrects magenta color saturation. [-63]...[63] • Factory setting: [0]
[Mg (PHASE)]	Corrects the magenta hue. [-63]...[63] • Factory setting: [0]
[Mg-B (SAT)]	Corrects the color saturation between magenta and blue. [-63]...[63] • Factory setting: [0]
[Mg-B (PHASE)]	Corrects the hue between magenta and blue. [-63]...[63] • Factory setting: [0]
[B (SAT)]	Corrects blue color saturation. [-63]...[63] • Factory setting: [0]
[B (PHASE)]	Corrects the blue hue. [-63]...[63] • Factory setting: [0]
[B-Cy (SAT)]	Corrects the color saturation between blue and cyan. [-63]...[63] • Factory setting: [0]
[B-Cy (PHASE)]	Corrects the hue between blue and cyan. [-63]...[63] • Factory setting: [0]
[Cy (SAT)]	Corrects cyan color saturation. [-63]...[63] • Factory setting: [0]
[Cy (PHASE)]	Corrects the cyan hue. [-63]...[63] • Factory setting: [0]
[Cy-G (SAT)]	Corrects the color saturation between cyan and green. [-63]...[63] • Factory setting: [0]
[Cy-G (PHASE)]	Corrects the hue between cyan and green. [-63]...[63] • Factory setting: [0]
[G (SAT)]	Corrects green color saturation. [-63]...[63] • Factory setting: [0]
[G (PHASE)]	Corrects the green hue. [-63]...[63] • Factory setting: [0]
[G-YI (SAT)]	Corrects the color saturation between green and yellow. [-63]...[63] • Factory setting: [0]
[G-YI (PHASE)]	Corrects the hue between green and yellow. [-63]...[63] • Factory setting: [0]
[YI (SAT)]	Corrects yellow color saturation. [-63]...[63] • Factory setting: [0]
[YI (PHASE)]	Corrects the yellow hue. [-63]...[63] • Factory setting: [0]
[YI-YI-R (SAT)]	Corrects the color saturation between yellow and "colors between yellow and red". [-63]...[63] • Factory setting: [0]
[YI-YI-R (PHASE)]	Corrects the hue between yellow and "colors between yellow and red". [-63]...[63] • Factory setting: [0]



## Chapter 6 Menu Operations — Menu list

Item	Description of settings
[YI-R (SAT)]	Corrects the color saturation between yellow and red. [-63]...[63] • Factory setting: [0]
[YI-R (PHASE)]	Corrects the hue between yellow and red. [-63]...[63] • Factory setting: [0]
[YI-R-R (SAT)]	Corrects the color saturation between “colors between yellow and red” and red. [-63]...[63] • Factory setting: [0]
[YI-R-R (PHASE)]	Corrects the hue between “colors between yellow and red” and red. [-63]...[63] • Factory setting: [0]
[MASTER PED]	Sets the master pedestal. [-200]...[200] • Factory setting: [16]
[RGB BLACK CONTROL SETTING]	
[R PED]	Sets the Rch pedestal level. [-100]...[100] • Factory setting: [0]
[G PED]	Sets the Gch pedestal level. [-100]...[100] • Factory setting: [0]
[B PED]	Sets the Bch pedestal level. [-100]...[100] • Factory setting: [0]
[PEDESTAL OFFSET]	Sets the Rch, Gch, and Bch pedestal levels after adjusting the automatic black balance. [ON]: Keeps each of the values set in [R PED], [G PED], and [B PED]. [OFF]: Sets the pedestal level of Rch, Gch, and Bch to [0]. • Factory setting: [OFF]
[GAMMA MODE SEL]	Selects the gamma curve. [HD]: The video gamma feature for HD (High Definition). [SD]: Increases gain in darker areas more than HD gamma. [FILMLIKE1]: Feature that reproduces more highlight areas compared to HD gamma. [FILMLIKE2]: Feature that reproduces more highlight areas compared to [FILMLIKE1]. [FILMLIKE3]: Feature that reproduces more highlight areas compared to [FILMLIKE2]. [FILM-REC]: The cine gamma feature for film. [VIDEO-REC]: The cine gamma feature for video. • Factory setting: [HD] When [FILM-REC] or [VIDEO-REC] is selected as the gamma mode, to fully utilize the feature, it is recommended that you set the lens aperture lower than the normal image level (approx. 1/2).
[GAMMA SETTING]	
[MASTER GAMMA]	Sets the master gamma in 0.01 steps. [0.30]...[0.75] • Factory setting: [0.45]
[F-REC DYNAMIC LVL]	When [FILM-REC] is selected in [GAMMA MODE SEL], dynamic range is set. If an item other than [FILM-REC] is selected, no settings are changed. [200%], [300%], [400%], [500%], [600%] • Factory setting: [600%]
[F-REC BLACK STR LVL]	When [FILM-REC] is selected in [GAMMA MODE SEL], black stretch is set. If an item other than [FILM-REC] is selected, no settings are changed. [0%]...[30%] • Factory setting: [0%]
[V-REC KNEE SLOPE]	When [VIDEO-REC] is selected in [GAMMA MODE SEL], knee slope is set. If an item other than [VIDEO-REC] is selected, no settings are changed. [150%], [200%]...[500%] • Factory setting: [500%]
[V-REC KNEE POINT]	When [VIDEO-REC] is selected in [GAMMA MODE SEL], knee point is set. If an item other than [VIDEO-REC] is selected, no settings are changed. [30%]...[107%] • Factory setting: [30%]
[BLACK GAMMA]	Sets the gamma curves of dark areas. [-8]...[-1]: Compresses the dark areas. [OFF]: Standard state [1]...[8]: Expands the dark areas. • Factory setting: [OFF]
[B. GAMMA RANGE]	Sets the maximum level of compression/expansion. [1]: About 20% [2]: About 30% [3]: About 40% • Factory setting: [1]
[KNEE SETTING]	
[KNEE MODE]	Sets the knee operation mode. [AUTO], [MANUAL], [OFF] • Factory setting: [AUTO]
[A.KNEE RESPONSE]	Sets the auto knee response speed. The smaller the setting value, the faster the response speed is. [1]...[8] • Factory setting: [4]

## Chapter 6 Menu Operations — Menu list

Item	Description of settings
[KNEE MASTER POINT]	Sets the knee point position in 0.5% steps. <b>[70.0%]...[107.0%]</b> • Factory setting: [93.0%]
[KNEE MASTER SLOPE]	Sets the knee inclination. <b>[0]...[99]</b> • Factory setting: [85]
[KNEE MASTER SLOPE Rch]	Sets the knee inclination of Rch. <b>[-31]...[31]</b> • Factory setting: [0]
[KNEE MASTER SLOPE Bch]	Sets the knee inclination of Bch. <b>[-31]...[31]</b> • Factory setting: [0]
[HI-COLOR SW]	Turns the mode that expands the color dynamic range [ON]/[OFF]. <b>[ON], [OFF]</b> • Factory setting: [ON]
[HI-COLOR LVL]	Selects the level of the mode that expands the color dynamic range. <b>[1]...[32]</b> • Factory setting: [32]
[WHITE CLIP SETTING]	
[WHITE CLIP]	Turns the white clip function [ON]/[OFF]. This enables the [WHITE CLIP LVL] setting value when the function is [ON]. <b>[ON], [OFF]</b> • Factory setting: [ON]
[WHITE CLIP LVL]	Sets the white clip level. <b>[90%]...[109%]</b> • Factory setting: [109%]
[Rch CLIP LVL]	Sets the clip level Rch for the white clips. <b>[-31]...[31]</b> • Factory setting: [0]
[Bch CLIP LVL]	Sets the clip level Bch for the white clips. <b>[-31]...[31]</b> • Factory setting: [0]
[DRS]	Enables/disables the dynamic range stretcher function. <b>[ON], [OFF]</b> • Factory setting: [OFF] If functions are assigned to the USER buttons, switches [ON]/[OFF] using the USER button operations.
[DRS EFFECT DEPTH]	Sets the compression level of the high-brightness areas of the dynamic range stretcher function. By compressing the video signal levels of the high-brightness areas that are blown out in normal shooting, the dynamic range can be expanded. <b>[1], [2], [3]</b> • Factory setting: [1]
[A.IRIS LEVEL]	Enables/disables the auto iris level function. <b>[ON], [OFF]</b> • Factory setting: [ON] If functions are assigned to the USER buttons, switches [ON]/[OFF] using the USER button operations.
[A.IRIS LEVEL EFFECT]	Adjusts the brightness in the auto iris mode. Increase the value to brighten, and decrease the value to darken the convergence of auto iris. <b>[-50]...[50]</b> • Factory setting: [0]

### [SYSTEM MODE]

Configure the settings regarding the recording format of video and audio.

Item	Description of settings
[LINE&FREQ]	Sets the signal format of the camera. If this setting has been changed, select [YES] on a confirmation message and restart the camera. <b>[1080-59.94P], [1080-50P], [1080-59.94i], [1080-50i], [1080-23.98PsF], [720-59.94P], [720-50P], [480-59.94i], [576-50i]</b>
[REC FORMAT]	Selects the codec for recording and the mode for shooting and recording. <b>[AVC-I200/60P], [AVC-I200/60i], [AVC-I200/50P], [AVC-I200/50i], [AVC-I200/30PN], [AVC-I200/25PN], [AVC-I200/24PN], [AVC-I100/60P], [AVC-I100/60i], [AVC-I100/50P], [AVC-I100/50i], [AVC-I100/30PN], [AVC-I100/24PN], [AVC-I100/25PN], [AVC-I50/60P], [AVC-I50/60i], [AVC-I50/50P], [AVC-I50/50i], [AVC-G50/60P], [AVC-G50/60i], [AVC-G50/50P], [AVC-G50/50i], [AVC-G25/60P], [AVC-G25/60i], [AVC-G25/50P], [AVC-G25/50i], [AVC-G12/60P], [AVC-G12/60i], [AVC-G12/50P], [AVC-G12/50i], [DVCPRO HD/60P], [DVCPRO HD/60i], [DVCPRO HD/50P], [DVCPRO HD/50i], [DVCPRO50/60i], [DVCPRO50/50i], [DVCPRO/60i], [DVCPRO/50i], [DV/60i], [DV/50i]</b>
[CAMERA MODE]	Sets the camera shooting mode for the 1080i SD mode. <b>[60i], [50i], [30P], [25P]</b>
[AUDIO SMPL RES]	Selects the number of audio bits ([24BIT] or [16BIT]) when [REC FORMAT] is [AVC-I100] or [AVC-I50]. At [REC FORMAT] other than these, recording is performed at the number of audio bits fixed to 24 bits or 16 bits. <b>[16BIT], [24BIT]</b>
[ASPECT CONV]	Selects the aspect ratio of the video to be recorded in 480i, 576i. <b>[SIDE CROP], [LETTER BOX], [SQUEEZE]</b> • Factory setting: [SIDE CROP]

## Chapter 6 Menu Operations — Menu list

Item	Description of settings
[SCAN REVERSE]	Enables/disables the scan reverse shooting function for vertical/horizontal inversion of images. [ON], [OFF] • Factory setting: [OFF]
[SETUP]	Sets the setup level of 480i video signals. [0%], [7.5%A]
[SHOOTING MODE]	Sets the shooting mode according to the shooting environment. [NORMAL]: Selects the shooting mode for an environment at normal brightness. [HIGH SENS.]: Selects high-sensitivity. (Appropriate when shooting in a dark environment.) The LCD monitor shows [H.SENS.]. • Factory setting: [NORMAL]

### [USER SW]

Set the functions to be assigned to the USER buttons (USER1 to USER8).

Item	Description of settings
[USER1]	Sets the function to be assigned to the <FOCUS ASSIST> button. [INHIBIT], [SCENE FILE SEL], [LEVEL GAUGE], [LEVEL GAUGE RESET], [WFM], [D.ZOOM], [DRS], [FBC], [S.GAIN], [1S.EXP.], [ATW], [ATW LOCK], [SPOTLIGHT], [BACKLIGHT], [BLACKFADE], [WHITEFADE], [A.IRIS LEVEL], [IRIS], [Y GET], [FOCUS ASSIST], [FOCUS MACRO], [OIS], [FAST ZOOM], [ZEBRA], [EVF ON/OFF], [PRE REC], [TEXT MEMO], [SHOT MARK], [DEL LAST CLIP], [SLOT SEL], [REC MEDIA], [AUDIO MON SEL], [REC CHECK], [BACKGR REC PAUSE], [USB MODE], [PLAYLIST] • Factory setting: [FOCUS ASSIST]
[USER2]	Sets the function to be assigned to the <MACRO> button. [INHIBIT], [SCENE FILE SEL], [LEVEL GAUGE], [LEVEL GAUGE RESET], [WFM], [D.ZOOM], [DRS], [FBC], [S.GAIN], [1S.EXP.], [ATW], [ATW LOCK], [SPOTLIGHT], [BACKLIGHT], [BLACKFADE], [WHITEFADE], [A.IRIS LEVEL], [IRIS], [Y GET], [FOCUS ASSIST], [FOCUS MACRO], [OIS], [FAST ZOOM], [ZEBRA], [EVF ON/OFF], [PRE REC], [TEXT MEMO], [SHOT MARK], [DEL LAST CLIP], [SLOT SEL], [REC MEDIA], [AUDIO MON SEL], [REC CHECK], [BACKGR REC PAUSE], [USB MODE], [PLAYLIST] • Factory setting: [FOCUS MACRO]
[USER3]	Sets the function to be assigned to the <OIS> button. [INHIBIT], [SCENE FILE SEL], [LEVEL GAUGE], [LEVEL GAUGE RESET], [WFM], [D.ZOOM], [DRS], [FBC], [S.GAIN], [1S.EXP.], [ATW], [ATW LOCK], [SPOTLIGHT], [BACKLIGHT], [BLACKFADE], [WHITEFADE], [A.IRIS LEVEL], [IRIS], [Y GET], [FOCUS ASSIST], [FOCUS MACRO], [OIS], [FAST ZOOM], [ZEBRA], [EVF ON/OFF], [PRE REC], [TEXT MEMO], [SHOT MARK], [DEL LAST CLIP], [SLOT SEL], [REC MEDIA], [AUDIO MON SEL], [REC CHECK], [BACKGR REC PAUSE], [USB MODE], [PLAYLIST] • Factory setting: [OIS]
[USER4]	Sets the function to be assigned to the <ZEBRA> button. [INHIBIT], [SCENE FILE SEL], [LEVEL GAUGE], [LEVEL GAUGE RESET], [WFM], [D.ZOOM], [DRS], [FBC], [S.GAIN], [1S.EXP.], [ATW], [ATW LOCK], [SPOTLIGHT], [BACKLIGHT], [BLACKFADE], [WHITEFADE], [A.IRIS LEVEL], [IRIS], [Y GET], [FOCUS ASSIST], [FOCUS MACRO], [OIS], [FAST ZOOM], [ZEBRA], [EVF ON/OFF], [PRE REC], [TEXT MEMO], [SHOT MARK], [DEL LAST CLIP], [SLOT SEL], [REC MEDIA], [AUDIO MON SEL], [REC CHECK], [BACKGR REC PAUSE], [USB MODE], [PLAYLIST] • Factory setting: [ZEBRA]
[USER5]	Sets the function to be assigned to the <WFM> button. [INHIBIT], [SCENE FILE SEL], [LEVEL GAUGE], [LEVEL GAUGE RESET], [WFM], [D.ZOOM], [DRS], [FBC], [S.GAIN], [1S.EXP.], [ATW], [ATW LOCK], [SPOTLIGHT], [BACKLIGHT], [BLACKFADE], [WHITEFADE], [A.IRIS LEVEL], [IRIS], [Y GET], [FOCUS ASSIST], [FOCUS MACRO], [OIS], [FAST ZOOM], [ZEBRA], [EVF ON/OFF], [PRE REC], [TEXT MEMO], [SHOT MARK], [DEL LAST CLIP], [SLOT SEL], [REC MEDIA], [AUDIO MON SEL], [REC CHECK], [BACKGR REC PAUSE], [USB MODE], [PLAYLIST] • Factory setting: [WFM]
[USER6]	Sets the function to be assigned to the <A.IRIS.LEVEL> button. [INHIBIT], [SCENE FILE SEL], [LEVEL GAUGE], [LEVEL GAUGE RESET], [WFM], [D.ZOOM], [DRS], [FBC], [S.GAIN], [1S.EXP.], [ATW], [ATW LOCK], [SPOTLIGHT], [BACKLIGHT], [BLACKFADE], [WHITEFADE], [A.IRIS LEVEL], [IRIS], [Y GET], [FOCUS ASSIST], [FOCUS MACRO], [OIS], [FAST ZOOM], [ZEBRA], [EVF ON/OFF], [PRE REC], [TEXT MEMO], [SHOT MARK], [DEL LAST CLIP], [SLOT SEL], [REC MEDIA], [AUDIO MON SEL], [REC CHECK], [BACKGR REC PAUSE], [USB MODE], [PLAYLIST] • Factory setting: [A.IRIS LEVEL]
[USER7]	Sets the function to be assigned to the <SLOT SEL> button. [INHIBIT], [SCENE FILE SEL], [LEVEL GAUGE], [LEVEL GAUGE RESET], [WFM], [D.ZOOM], [DRS], [FBC], [S.GAIN], [1S.EXP.], [ATW], [ATW LOCK], [SPOTLIGHT], [BACKLIGHT], [BLACKFADE], [WHITEFADE], [A.IRIS LEVEL], [IRIS], [Y GET], [FOCUS ASSIST], [FOCUS MACRO], [OIS], [FAST ZOOM], [ZEBRA], [EVF ON/OFF], [PRE REC], [TEXT MEMO], [SHOT MARK], [DEL LAST CLIP], [SLOT SEL], [REC MEDIA], [AUDIO MON SEL], [REC CHECK], [BACKGR REC PAUSE], [USB MODE], [PLAYLIST] • Factory setting: [SLOT SEL]

Chapter 6 Menu Operations — Menu list

Item	Description of settings
[USER8]	<p>Sets the function to be assigned to the &lt;IRIS&gt; button.</p> <p>[INHIBIT], [SCENE FILE SEL], [LEVEL GAUGE], [LEVEL GAUGE RESET], [WFM], [D.ZOOM], [DRS], [FBC], [S.GAIN], [1S.EXP.], [ATW], [ATW LOCK], [SPOTLIGHT], [BACKLIGHT], [BLACKFADE], [WHITEFADE], [A.IRIS LEVEL], [IRIS], [Y GET], [FOCUS ASSIST], [FOCUS MACRO], [OIS], [FAST ZOOM], [ZEBRA], [EVF ON/OFF], [PRE REC], [TEXT MEMO], [SHOT MARK], [DEL LAST CLIP], [SLOT SEL], [REC MEDIA], [AUDIO MON SEL], [REC CHECK], [BACKGR REC PAUSE], [USB MODE], [PLAYLIST]</p> <ul style="list-style-type: none"> <li>• Factory setting: [IRIS]</li> </ul>

**[SW MODE]**

Configure the settings of each mode when switched using each switch.  
 These menu items cannot be set when the thumbnail screen is displayed.

Item	Description of settings
[LOW GAIN]	<p>Sets the gain value to be assigned to the &lt;L&gt; position of the &lt;GAIN&gt; switch. (Negative value of gain is only in [HIGH SENS.] mode.)</p> <p>[-3dB]...[18dB]</p> <ul style="list-style-type: none"> <li>• Factory setting: [0dB]</li> </ul>
[MID GAIN]	<p>Sets the gain value to be assigned to the &lt;M&gt; position of the &lt;GAIN&gt; switch. (Negative value of gain is only in [HIGH SENS.] mode.)</p> <p>[-3dB]...[18dB]</p> <ul style="list-style-type: none"> <li>• Factory setting: [6dB]</li> </ul>
[HIGH GAIN]	<p>Sets the gain value to be assigned to the &lt;H&gt; position of the &lt;GAIN&gt; switch. (Negative value of gain is only in [HIGH SENS.] mode.)</p> <p>[-3dB]...[18dB]</p> <ul style="list-style-type: none"> <li>• Factory setting: [12dB]</li> </ul>
[SUPER GAIN]	<p>Sets the super gain to be assigned to the USER button.</p> <p>[24dB], [30dB], [36dB]</p> <p>[ALL]: Each time the USER button is pressed, the setting toggles [24dB] → [30dB] → [36dB] → (off) in order.</p> <ul style="list-style-type: none"> <li>• Factory setting: [36dB]</li> </ul>
[OIS]	<p>Enables/disables the image stabilizer function.</p> <p>[ON]: Enables the image stabilizer function.</p> <p>[OFF]: Disables the image stabilizer function.</p> <ul style="list-style-type: none"> <li>• Factory setting: [ON]</li> </ul> <p>If functions are assigned to the USER buttons, switches [ON]/[OFF] using the USER button operations.</p>
[ATW]	<p>Assigns the auto tracking white balance function to the &lt;WHITE BAL&gt; switch.</p> <p>[Ach], [Bch], [PRE], [OFF]</p> <ul style="list-style-type: none"> <li>• Factory setting: [OFF]</li> </ul>
[ATW SPEED]	<p>Sets the control speed of the auto tracking white balance function.</p> <p>[FAST], [NORMAL], [SLOW]</p> <ul style="list-style-type: none"> <li>• Factory setting: [NORMAL]</li> </ul>
[ATW TARGET R]	<p>Finely adjusts the Rch output for convergence with auto tracking white balance operation.</p> <p>[-10]...[10]</p> <ul style="list-style-type: none"> <li>• Factory setting: [0]</li> </ul>
[ATW TARGET B]	<p>Finely adjusts the Bch output for convergence with auto tracking white balance operation.</p> <p>[-10]...[10]</p> <ul style="list-style-type: none"> <li>• Factory setting: [0]</li> </ul>
[W.BAL PRESET]	<p>Sets the color temperature to be assigned to the &lt;PRST&gt; position of the &lt;WHITE BAL&gt; switch.</p> <p>[3200K], [5600K], [VAR]</p> <ul style="list-style-type: none"> <li>• Factory setting: [3200K]</li> </ul>
[W.BAL VAR]	<p>Sets the value of [VAR] in [W.BAL PRESET].</p> <p>It can also be operated by the &lt;SEL/PUSH SET&gt; dial button.</p> <p>Enabled when [W.BAL PRESET] is set to [VAR] and the &lt;WHITE BAL&gt; switch is at &lt;PRST&gt;.</p> <p>[2000K]...[15000K]</p> <ul style="list-style-type: none"> <li>• Factory setting: [3200K]</li> </ul>
[H.ZOOM SPEED]	<p>Sets the zoom speed when the HANDLE ZOOM switch is &lt;FIX&gt;.</p> <p>[1]...[99]</p> <ul style="list-style-type: none"> <li>• Factory setting: [50]</li> </ul>
[PUSH AF MODE]	<p>Assigns the operation mode when the &lt;PUSH AUTO&gt; button is pressed.</p> <p>[TURBO]: Performs high-speed focusing automatically until the image is focused, once the button is pressed.</p> <p>[NORMAL]: Performs automatic focusing while pressing the button.</p> <ul style="list-style-type: none"> <li>• Factory setting: [TURBO]</li> </ul>
[MF ASSIST]	<p>Sets whether to adjust the last focus automatically when in the manual focus mode.</p> <p>[ON]: Adjusts the last focus automatically.</p> <p>[OFF]: Does not adjust the focus automatically.</p> <ul style="list-style-type: none"> <li>• Factory setting: [OFF]</li> </ul> <p>If the image is largely out of focus, the focus may not be adjusted properly.</p> <p>Operations with a remote control connected to the &lt;CAM REMOTE&gt; terminal are not available.</p>

## Chapter 6 Menu Operations — Menu list

Item	Description of settings
[FOCUS ASSIST MODE]	Sets the operation mode of the focus assist function. <b>[EXPAND]</b> : Expands the center part of the screen of the LCD monitor. <b>[IN RED]</b> : Outlines the contour of the video in red. <ul style="list-style-type: none"> <li>• Factory setting: [EXPAND]</li> </ul> If functions are assigned to the USER buttons, on and off of the function can be switched using the USER button operations.
[MACRO]	Enables/disables the focus macro function. <b>[ON]</b> : Enables the focus macro function. <b>[OFF]</b> : Disables the focus macro function. <ul style="list-style-type: none"> <li>• Factory setting: [OFF]</li> </ul> If functions are assigned to the USER buttons, switches [ON]/[OFF] using the USER button operations.
[MACRO MODE]	Sets the operation mode when the focus macro function is enabled. <b>[WIDE]</b> : Only the wide macro area is enabled. <b>[ALL]</b> : Tele macro area and wide macro area are enabled. <ul style="list-style-type: none"> <li>• Factory setting: [WIDE]</li> </ul>
[A.IRIS SPEED]	Sets the control speed of the auto iris function. <b>[FAST], [NORMAL], [SLOW]</b> <ul style="list-style-type: none"> <li>• Factory setting: [NORMAL]</li> </ul>
[A.IRIS WINDOW]	Selects the auto iris detection window. <b>[NORM1]</b> : Window that is near screen center. <b>[NORM2]</b> : Window that is near screen bottom. <b>[CENTER]</b> : Window that is a spot in the screen center. <ul style="list-style-type: none"> <li>• Factory setting: [NORM1]</li> </ul>
[AREA MODE]	Assigns the function to be performed within the area selected using the control stick during shooting. <b>[INHIBIT]</b> : Does not allocate a function. <b>[FOCUS]</b> : Auto focus/focus bar function <b>[IRIS]</b> : Auto iris function <b>[Y GET]</b> : Brightness display function <b>[FOCUS/IRIS]</b> : Activates [FOCUS] and [IRIS] simultaneously. <b>[FOCUS/Y GET]</b> : Activates [FOCUS] and [Y GET] simultaneously. <ul style="list-style-type: none"> <li>• Factory setting: [INHIBIT]</li> </ul>
[WFM MODE]	Selects the type of waveform to be displayed on the LCD monitor when the <WFM> button is pressed. <b>[WAVE]</b> : Displays as a waveform. <b>[VECTOR]</b> : Displays as a vector. <b>[WAVE/VECTOR]</b> : Each time the <WFM> button is pressed, the display changes in order from (no display) → [WAVE] (waveform) → [VECTOR] (vector) → (no display). <ul style="list-style-type: none"> <li>• Factory setting: [WAVE]</li> </ul>
[ZEBRA]	Displays/hides zebra patterns. <b>[ON]</b> : Displays zebra patterns. <b>[OFF]</b> : Does not display zebra patterns. <ul style="list-style-type: none"> <li>• Factory setting: [OFF]</li> </ul> If functions are assigned to the USER buttons, switches [ON]/[OFF] using the USER button operations.
[ZEBRA MODE]	Selects whether to keep displaying zebra patterns. <b>[CONTINUE]</b> : Keep the display of zebra patterns. <b>[MOMENT]</b> : Displays zebra patterns for approximately five seconds. <ul style="list-style-type: none"> <li>• Factory setting: [MOMENT]</li> </ul>
[BARS TYPE]	Selects the color bar to use. <b>[SMPTE]</b> : Uses the color bar in the SMPTE standard. <b>[FULL BARS]</b> : Uses full color bars. <b>[SPLIT]</b> : Uses SPLIT color bars for SNG (Satellite News Gathering). <b>[ARIB]</b> : Uses ARIB standard color bars. <ul style="list-style-type: none"> <li>• Factory setting: [SMPTE]</li> </ul>
[FRONT REC]	Sets operation of the REC button on the front of the camera. <b>[INHIBIT]</b> : Does not activate the operation. <b>[ACTIVE]</b> : Activates the operation. <ul style="list-style-type: none"> <li>• Factory setting: [ACTIVE]</li> </ul>

### [AUTO SW]

Configure the settings regarding the auto mode.

Auto iris, auto gain control, auto tracking white balance, and auto focus functions can be set separately.

These menu items cannot be set when the thumbnail screen is displayed.

Item	Description of settings
[A.IRIS]	Enables/disables the auto iris control. <b>[ON]</b> : Performs the auto iris control operation when in auto mode. The <IRIS> button does not work. <b>[OFF]</b> : Auto iris control operation is not performed during auto mode. This activates the iris control selected with the <IRIS> button. <ul style="list-style-type: none"> <li>• Factory setting: [ON]</li> </ul>
[AGC]	Sets the auto gain control operations when [ON] is selected in [A.IRIS]. <b>[ON]</b> : Performs the operation of the [AGC] function that automatically adjusts camera gain when in auto mode. <b>[OFF]</b> : Does not perform the operation of the [AGC] function that automatically adjusts camera gain when in auto mode. <ul style="list-style-type: none"> <li>• Factory setting: [ON]</li> </ul>

## Chapter 6 Menu Operations — Menu list

Item	Description of settings
[AGC LIMIT]	Sets the maximum gain value during [AGC] operation. <b>[3dB], [6dB], [12dB], [18dB]</b> • Factory setting: [6dB]
[AGC POINT]	Sets the F value to switch control to [AGC] from auto iris during [AGC] operation. <b>[F4.0], [F5.6]</b> • Factory setting: [F4.0]
[A.SHUTTER]	Sets the auto shutter control operations when [ON] is selected in [A.IRIS]. <b>[ON]</b> : Performs the operation of auto shutter when in auto mode. <b>[OFF]</b> : Does not perform the operation of auto shutter when in auto mode. • Factory setting: [ON]
[A.SHUTTER LIMIT]	Sets the maximum shutter value during [A.SHUTTER] operation. <b>[1/100], [1/120], [1/250]</b> • Factory setting: [1/250]
[A.SHUTTER POINT]	Sets the F value to switch control from auto iris to [A.SHUTTER] during [A.SHUTTER] operation. <b>[F8.0], [F9.6]</b> • Factory setting: [F8.0]
[ATW]	Sets the operations of the auto tracking white balance function. <b>[ON]</b> : Activates the auto tracking white balance function when in auto mode. The [ATW] function cannot be switched between enabled and disabled with the <WHITE BAL> switch or USER buttons. However, if [ATW LOCK] is assigned to the USER button, the white balance value can be fixed with the USER button. <b>[OFF]</b> : Does not perform the operation of the [ATW] function when in auto mode. Performs the operation of the white balance function selected with the <WHITE BAL> switch. • Factory setting: [ON]
[AF]	Sets the operation of the auto focus. <b>[ON]</b> : Performs the operation of auto focus when in auto mode. The <FOCUS> switch does not work. <b>[OFF]</b> : Does not perform the operation of auto focus when in auto mode. Activates the focus function selected with the <FOCUS> switch. • Factory setting: [ON]

### [RECORDING SETUP]

These are various types of setting items when performing camera recording and playback.

Set the system frequency, the number of lines, recording format, and recording method.

Item	Description of settings	
[REC MEDIA]	Selects the slot for the media to be recorded. <b>[microP2]</b> : Uses microP2 memory cards (slots 1 and 2). <b>[P2]</b> : Uses P2 memory card (card slot 3). • Factory setting: [microP2]	
[FILE SPLIT]	Selects whether to divide the recording file in 4 GB units or one file when recording in the microP2 memory card (that exceeds 32 GB) in AVC-LongG format. <b>[ONE FILE]</b> : Records in one file. <b>[SPLIT]</b> : Splits the clip every 4 GB. • Factory setting: [SPLIT]	
[RECORDING]	Selects the recording format. <b>[NORMAL]</b> : Performs standard recording. <b>[INTERVAL]</b> : Performs interval recording. <b>[ONE SHOT]</b> : Performs one-shot recording. <b>[LOOP]</b> : Performs loop recording. • Factory setting: [NORMAL]	
[RECORDING SETTING]	[RECORDING HOLD]	Selects whether to hold [RECORDING] settings. <b>[ON]</b> : Holds the settings. <b>[OFF]</b> : Does not hold the settings. It will always be [NORMAL] the next time when the power is turned on. • Factory setting: [OFF]
	[ONE SHOT TIME]	Sets the recording duration of one-shot recording. <b>[1frm], [2frm], [4frm], [8frm], [16frm], [1s]</b> • Factory setting: [1frm]
	[INTERVAL TIME]	Sets the interval duration for interval recording. <b>[2frm], [4frm], [8frm], [16frm], [1s], [2s], [5s], [10s], [30s], [1min], [5min], [10min]</b> • Factory setting: [2frm]
	[START DELAY]	Selects whether to delay the recording start time by approximately one second when performing interval recording or one-shot recording. <b>[ON], [OFF]</b> • Factory setting: [OFF]
[PRE REC]	Selects whether to perform pre-recording. If [ON] is selected, pre-recording is performed for approximately three seconds in HD, and for approximately seven seconds in SD. <b>[ON], [OFF]</b> • Factory setting: [OFF]	
[ONE CLIP REC]	Selects whether to perform one-clip recording. <b>[ON], [OFF]</b> • Factory setting: [OFF]	
[SIMUL REC]	Selects whether to perform simultaneous recording. <b>[ON], [OFF]</b> • Factory setting: [OFF]	

Chapter 6 Menu Operations — Menu list

Item	Description of settings								
[BACKGROUND REC]	Selects whether to perform background recording. <b>[ON], [OFF]</b> • Factory setting: [OFF]								
[DUAL CODEC SETTING]	<table border="1"> <tr> <td data-bbox="347 241 571 443">[CODEC USAGE]</td> <td data-bbox="571 241 1476 443">                             Selects media for recording proxy data.  <b>[PROXY REC(P2)]</b>: Records proxy data to a P2 card.  <b>[PROXY REC(P2&amp;SD)]</b>: Records proxy data to both of a P2 card and SD memory card.  <b>[STREAMING]</b>: Outputs streaming.  <b>[OFF]</b>: Does not record proxy data.                              • Factory setting: [OFF]                              If the [CODEC USAGE] setting cannot be changed, change the [PROXY REC MODE] or [STREAMING MODE] setting.                         </td> </tr> <tr> <td data-bbox="347 443 571 521">[STREAMING MODE]</td> <td data-bbox="571 443 1476 521">                             Sets the transfer mode for streaming.  <b>[LOW], [HQ], [AVC-G6], [SHQ (QoS)], [AVC-G (QoS)]</b>                              • Factory setting: [HQ]                         </td> </tr> <tr> <td data-bbox="347 521 571 600">[PROXY REC MODE]</td> <td data-bbox="571 521 1476 600">                             Sets the recording mode of proxy data.  <b>[LOW 2CH MOV], [HQ 2CH MOV], [SHQ 2CH MOV], [AVC-G6 2CH MOV]</b>                              • Factory setting: [HQ 2CH MOV]                         </td> </tr> <tr> <td data-bbox="347 600 571 772">[PROXY DISP]</td> <td data-bbox="571 600 1476 772">                             Selects whether to display proxy data recorded information or messages in the viewfinder and LCD monitor.  <b>[ON]</b>: Displays proxy recording information and SD memory card remaining capacity at the start of recording. Warning information is displayed at all times.  <b>[OFF]</b>: Displays proxy and SD memory card warning information for only three seconds when warning occurs.                              • Factory setting: [OFF]                         </td> </tr> </table>	[CODEC USAGE]	Selects media for recording proxy data. <b>[PROXY REC(P2)]</b> : Records proxy data to a P2 card. <b>[PROXY REC(P2&amp;SD)]</b> : Records proxy data to both of a P2 card and SD memory card. <b>[STREAMING]</b> : Outputs streaming. <b>[OFF]</b> : Does not record proxy data. • Factory setting: [OFF] If the [CODEC USAGE] setting cannot be changed, change the [PROXY REC MODE] or [STREAMING MODE] setting.	[STREAMING MODE]	Sets the transfer mode for streaming. <b>[LOW], [HQ], [AVC-G6], [SHQ (QoS)], [AVC-G (QoS)]</b> • Factory setting: [HQ]	[PROXY REC MODE]	Sets the recording mode of proxy data. <b>[LOW 2CH MOV], [HQ 2CH MOV], [SHQ 2CH MOV], [AVC-G6 2CH MOV]</b> • Factory setting: [HQ 2CH MOV]	[PROXY DISP]	Selects whether to display proxy data recorded information or messages in the viewfinder and LCD monitor. <b>[ON]</b> : Displays proxy recording information and SD memory card remaining capacity at the start of recording. Warning information is displayed at all times. <b>[OFF]</b> : Displays proxy and SD memory card warning information for only three seconds when warning occurs. • Factory setting: [OFF]
[CODEC USAGE]	Selects media for recording proxy data. <b>[PROXY REC(P2)]</b> : Records proxy data to a P2 card. <b>[PROXY REC(P2&amp;SD)]</b> : Records proxy data to both of a P2 card and SD memory card. <b>[STREAMING]</b> : Outputs streaming. <b>[OFF]</b> : Does not record proxy data. • Factory setting: [OFF] If the [CODEC USAGE] setting cannot be changed, change the [PROXY REC MODE] or [STREAMING MODE] setting.								
[STREAMING MODE]	Sets the transfer mode for streaming. <b>[LOW], [HQ], [AVC-G6], [SHQ (QoS)], [AVC-G (QoS)]</b> • Factory setting: [HQ]								
[PROXY REC MODE]	Sets the recording mode of proxy data. <b>[LOW 2CH MOV], [HQ 2CH MOV], [SHQ 2CH MOV], [AVC-G6 2CH MOV]</b> • Factory setting: [HQ 2CH MOV]								
[PROXY DISP]	Selects whether to display proxy data recorded information or messages in the viewfinder and LCD monitor. <b>[ON]</b> : Displays proxy recording information and SD memory card remaining capacity at the start of recording. Warning information is displayed at all times. <b>[OFF]</b> : Displays proxy and SD memory card warning information for only three seconds when warning occurs. • Factory setting: [OFF]								
[START TEXT MEMO]	Selects whether to automatically add a text memo at recording start position each time recording is started. <b>[ON], [OFF]</b> • Factory setting: [OFF]								
[TIME STAMP]	Selects whether to superimpose [DATE]/[TIME] information on shot videos. <b>[ON]</b> : Superimposes information set in the [DATE]/[TIME] item on video. <b>[OFF]</b> : Does not superimpose information set in the [DATE]/[TIME] item on video. • Factory setting: [OFF]								
[DF MODE]	Sets the counting method of the built-in time code generator. <b>[DF]</b> : Uses the drop frame mode. <b>[NDF]</b> : Uses the non-drop frame mode. • Factory setting: [DF]								
[TCG]	Sets the operation mode to advance the built-in time code generator. <b>[FREE RUN]</b> : Advances regardless of the operation mode. <b>[REC RUN]</b> : Advances when recording is in process. • Factory setting: [REC RUN] In native recording in variable frame rate mode, if the number of frames differs for shooting and recording, the time code operation will be [REC RUN].								
[TC PRESET]	Sets the default value of the time code to record.								
[UBG MODE]	Selects the user bits mode. <b>[USER]</b> : Selects the user bits value that has been set. <b>[TIME]</b> : Selects the local time. (hh, mm, ss) <b>[DATE]</b> : Selects the local date and time. (YY, MM, DD, hh) <b>[EXT]</b> : Records the user bits values currently input to the <TC IN/OUT> terminal. <b>[TCG]</b> : The value of [TCG] is recorded as user bits. <b>[FRAME RATE]</b> : Selects camera imaging information (such as frame rate). <b>[REGEN]</b> : Reads the value recorded to the card and continuously records that value. • Factory setting: [USER]								
[UB PRESET]	Sets user bits. Note that [USER] must be set for [UBG MODE].								
[VITC UBG MODE]	Selects the VITC user bits mode. <b>[USER/EXT]</b> : When [UBG MODE] is [EXT], follows the value and when other than [EXT], records the user value set in [USER]. <b>[TIME]</b> : Selects the local time. (hh, mm, ss) <b>[DATE]</b> : Selects the local date and time. (YY, MM, DD, hh) <b>[TCG]</b> : The value of time code generator is recorded as user bits. <b>[FRAME RATE]</b> : Selects camera imaging information (such as frame rate). <b>[REGEN]</b> : Reads the value recorded to the card and continuously records that value. • Factory setting: [USER/EXT]								
[REC META DATA]	<table border="1"> <tr> <td data-bbox="347 1720 571 1747">[LOAD]</td> <td data-bbox="571 1720 1476 1747">                             Loads the metadata upload file saved to the SD memory card.                         </td> </tr> <tr> <td data-bbox="347 1753 571 1854">[RECORD]</td> <td data-bbox="571 1753 1476 1854">                             Sets whether to add loaded metadata at a recording.  <b>[ON]</b>: Adds metadata.  <b>[OFF]</b>: Does not add metadata.                              • Factory setting: [OFF]                         </td> </tr> <tr> <td data-bbox="347 1861 571 2047">[USER CLIP NAME]</td> <td data-bbox="571 1861 1476 2047">                             Sets data to be recorded to [USER CLIP NAME].                              (When [RECORD] is [ON])  <b>[TYPE1]</b>: Records setting values of the loaded data.  <b>[TYPE2]</b>: Records the loaded data and counter value.                              (When [RECORD] is [OFF])  <b>[TYPE1]</b>: Records the same value as [GLOBAL CLIP ID].  <b>[TYPE2]</b>: Records the same value as [CLIP NAME].                              • Factory setting: [TYPE1]                         </td> </tr> </table>	[LOAD]	Loads the metadata upload file saved to the SD memory card.	[RECORD]	Sets whether to add loaded metadata at a recording. <b>[ON]</b> : Adds metadata. <b>[OFF]</b> : Does not add metadata. • Factory setting: [OFF]	[USER CLIP NAME]	Sets data to be recorded to [USER CLIP NAME]. (When [RECORD] is [ON]) <b>[TYPE1]</b> : Records setting values of the loaded data. <b>[TYPE2]</b> : Records the loaded data and counter value. (When [RECORD] is [OFF]) <b>[TYPE1]</b> : Records the same value as [GLOBAL CLIP ID]. <b>[TYPE2]</b> : Records the same value as [CLIP NAME]. • Factory setting: [TYPE1]		
[LOAD]	Loads the metadata upload file saved to the SD memory card.								
[RECORD]	Sets whether to add loaded metadata at a recording. <b>[ON]</b> : Adds metadata. <b>[OFF]</b> : Does not add metadata. • Factory setting: [OFF]								
[USER CLIP NAME]	Sets data to be recorded to [USER CLIP NAME]. (When [RECORD] is [ON]) <b>[TYPE1]</b> : Records setting values of the loaded data. <b>[TYPE2]</b> : Records the loaded data and counter value. (When [RECORD] is [OFF]) <b>[TYPE1]</b> : Records the same value as [GLOBAL CLIP ID]. <b>[TYPE2]</b> : Records the same value as [CLIP NAME]. • Factory setting: [TYPE1]								



## Chapter 6 Menu Operations — Menu list

Item	Description of settings
[CARD SERIAL]	Enables/disables the function for recording the text memo with the serial number or the type of card as metadata. <b>[ON], [OFF]</b> • Factory setting: [OFF]
[INITIALIZE]	Deletes all loaded metadata and initializes.
[PROPERTY]	Checks and corrects loaded metadata.

### [CLIP]

This menu is used when performing various tasks, such as playing back, deleting, copying clips, and editing metadata, while viewing the thumbnail of the clips displayed in the viewfinder or LCD monitor.

These menu items are enabled when the thumbnail screen is displayed.

Clip operations such as [DELETE] or [COPY] are enabled when the target thumbnail is selected.

Some items are displayed only in specific situations such as in USB host mode or on the explorer screen.

Item	Description of settings
[REPOSITION]	Selects a clip to be displayed on the thumbnail screen. <b>[ALL CLIP]</b> : Displays all clips as thumbnails. <b>[SAME FORMAT CLIPS]</b> : Displays only the clips recorded in the same format as the system format as thumbnails. Clips recorded in the same format means that each item of [LINE&FREQ], [REC FORMAT], and [AUDIO SMPLE RES] in the main menu → [SYSTEM MODE] matches the current setting status. Example) [1080-59.94i], [AVC-I100], [24BIT] <b>[SELECTED CLIPS]</b> : Displays only the clips selected with the control stick as thumbnails. The thumbnails appear in selected order. <b>[MARKED CLIPS]</b> : Displays only the clips with shot marks added as thumbnails. <b>[TEXT MEMO CLIPS]</b> : Displays only clips with text memo data attached as thumbnails. <b>[SLOT CLIPS]</b> : Displays only the clips of the selected slot as thumbnails. <b>[NG CLIPS]</b> : Displays only the clips with defective clip indicators added as thumbnails. • Factory setting: [ALL CLIP]
[DELETE]	Deletes selected clips.
[FORMAT]	When the [FORMAT] menu is selected, format the P2 card of the specified slot. <b>[SLOT 1], [SLOT 2], [SLOT 3], [SD CARD]</b> • When a CPS password is set, you can select [NORMAL] (normal unencrypted format) or [CPS(ENCRYPT)] (encrypted format). • Data deleted as a result of formatting cannot be restored. Always check the data before formatting.
[FORMAT(STORAGE)]	When in USB host mode, formats a storage device connected to the <USB3.0 HOST> terminal using the specified file system. <b>[TYPE S]</b> : Formats in the [TYPE S] format. <b>[FAT]</b> : Formats in the [FAT] format. This item is enabled only while the storage explorer screen or storage thumbnail screen is displayed.
[COPY]	Copies the selected clip to a P2 card in any card slot or a storage device. <b>[SLOT 1], [SLOT 2], [SLOT 3], [SD CARD], [STORAGE], [FTP], [FTP(PROXY)]</b> This item cannot be selected while the storage thumbnail screen or FTP thumbnail screen is displayed.
[EXPORT]	Exports (writes) from the P2 card or SD memory card to a storage device or FTP by units of card. <b>[ALL SLOT], [SLOT 1], [SLOT 2], [SLOT 3]</b> : Exports clips from the P2 card to a storage device. <b>[SD CARD]</b> : Exports from the the SD memory card to FTP.
[IMPORT]	Imports (writes back) clips, etc. from a storage device or FTP to the P2 card or SD memory card by units of card. <b>[SLOT 1], [SLOT 2], [SLOT 3], [SD CARD]</b> This item cannot be selected while the storage thumbnail screen or FTP thumbnail screen is displayed.
[REPAIR]	Repairs a clip displayed in the defective clip indicator (yellow) occurring as a result of sudden power loss during recording or other reasons.
[RE-CONNECT]	If clips that were recorded over multiple P2 cards are not recognized as consecutive clips and the incomplete clip indicator  is displayed, use this function to restore the clips to the consecutive clips (the original combined clips).
[EXCH. THUMBNAIL]	Changes the clip thumbnail to an image with any text memo. This can be executed while the text memo clip is displayed.
[EXPLORE]	Switches to the information display screen for storage device and network connection. <b>[STORAGE]</b> : Switches to the information display screen for storage device. <b>[FTP]</b> : Switches to the information display screen for FTP server.
[AUTHENTICATE]	When this menu is selected from the card status screen, a software keyboard is displayed to enter the CPS password. If the password is entered and [OK] is selected, the CPS password is set to the camera. When the set CPS password is successfully authenticated, the message [AUTHENTICATED SUCCESSFULLY!] is displayed. When the set CPS password authentication fails, a warning message is displayed.
[CHANGE PARTITION NAME]	When in USB host mode, sets/changes the partition name of the storage device. • The default value is the date and time when the partition was created. • This item is enabled only for the [TYPE S] storage device. • This item is displayed only when the storage explore screen is displayed.
[DELETE LAST PARTITION]	When in USB host mode, deletes the last storage partition. • The partition can be deleted only when the cursor is placed on the last partition. • This item is displayed only when the storage explore screen is displayed.
[DELETE FOLDER]	Delete folders in the storage device in the FAT format.
[PROPERTY]	[CLIP PROPERTY] Detailed clip information is displayed on the screen. Items can be individually corrected.



## Chapter 6 Menu Operations — Menu list

Item	Description of settings
[CARD STATUS]	Displays the card status of a card slot.
[CPS PASSWORD]	Sets the CPS encrypted password of the microP2 memory card. <b>[LOAD]</b> : Loads CPS password from an SD memory card. <b>[SET]</b> : Enters the CPS password. <b>[DELETE]</b> : Deletes the password saved to the device, and disables encrypted formats.
[SD CARD]	Displays SD memory card information.
[REMAIN SETUP]	Sets which is displayed, remaining capacity or used capacity, when P2 card information is displayed. <b>[REMAIN]</b> : Displays remaining capacity. <b>[USED]</b> : Displays used capacity. • Factory setting: [REMAIN]
[FREE CAP. OF PARTITION]	Displays available space in a partition.
[THUMBNAIL SETUP]	[INDICATOR] Selects an item to display and press the control stick. Checked items are displayed. When [ALL HIDE] is selected, other items cannot be selected. <b>[ALL HIDE]</b> : Hides all indicators. <b>[MARKER]</b> : Displays the shot mark indicator. <b>[TEXT MEMO]</b> : Displays the text memo indicator. <b>[WIDE]</b> : Displays the wide indicator. <b>[PROXY]</b> : Displays the proxy indicator. • Factory setting: [MARKER], [TEXT MEMO], [WIDE], [PROXY]
	[DATA DISPLAY] Selects the content to be displayed in the time code display area. <b>[TC]</b> : Displays the time code. <b>[UB]</b> : Displays the user bits. <b>[TIME]</b> : Displays the record time. <b>[DATE]</b> : Displays the record date. <b>[DATE TIME]</b> : Displays the record date and time. <b>[CLIP NAME]</b> : Displays clip names. <b>[USER CLIP NAME]</b> : Displays a maximum of the first 15 letters (for an English language display) of a user clip name. <b>[SLOT]</b> : Displays slot number. <b>[THUMBNAIL TC]</b> : Displays the time code of the thumbnail position. • Factory setting: [TC]
	[THUMBNAIL SIZE] Sets the thumbnail size displayed in a thumbnail on the screen. <b>[SMALL]</b> : Small (thumbnail display: with 4×3 and property display) <b>[MEDIUM]</b> : Standard (thumbnail display: 4×3) <b>[LARGE]</b> : Large (thumbnail display: 3×2) • Factory setting: [MEDIUM]
	[PB POSITION] Sets the playback start position during playback from the thumbnail screen. <b>[RESUME]</b> : Plays back from the position where playback stopped. <b>[THUMBNAIL TC]</b> : Plays back from the time code of the thumbnail position. <b>[START TC]</b> : Plays back from the start time code (beginning of the clip). • Factory setting: [START TC]
	[PROPERTY DISP.] Sets simple properties item displayed on the left of the thumbnail when [SMALL] is selected for [THUMBNAIL SIZE]. <b>[USER CLIP NAME]</b> : Displays the user clip name. <b>[START TC]</b> : Displays the start time code. <b>[REC DATE]</b> : Displays the recorded date. <b>[REC TIME]</b> : Displays the recorded time. <b>[NUM. OF AUDIO CH]</b> : Displays the number of audio channels. <b>[AUDIO RATE]</b> : Displays the audio sampling rate. <b>[AUDIO BIT]</b> : Displays the audio bitrate. <b>[CREATOR]</b> : Displays the person who recorded the clip. <b>[SHOOTER]</b> : Displays the videographer. <b>[PLACE NAME]</b> : Displays the shooting location. <b>[PROGRAM NAME]</b> : Displays the program name. <b>[SCENE NO.]</b> : Displays the scene number. <b>[TAKE NO.]</b> : Displays the take number. <b>[REPORTER]</b> : Displays the reporter. <b>[PURPOSE]</b> : Displays the purpose of shooting. <b>[OBJECT]</b> : Displays the object of shooting. <b>[START UB]</b> : Displays the start user bits. <b>[REC RATE]</b> : Displays the recording frame rate. <b>[LAST UP DATE]</b> : Displays the date of last update. <b>[LAST UP PERSON]</b> : Displays the last person who updated. <b>[MANUFACTURER]</b> : Displays the equipment manufacturer name. <b>[SERIAL NO.]</b> : Displays the serial number. <b>[MODEL NAME]</b> : Displays the model name. <b>[ALTITUDE]</b> : Displays an altitude. <b>[LONGITUDE]</b> : Displays a longitude. <b>[LATITUDE]</b> : Displays a latitude. <b>[1ST TEXT MEMO]</b> : Displays the first text memo content. <b>[THUMBNAIL OFFSET]</b> : Displays the thumbnail recording position.
	[THUMBNAIL INFO.] Displays the number of selected clips and playback time of clip, etc. <b>[NUM. OF CLIPS]</b> : Displays the number of selected clips at the lower right of the thumbnail screen. <b>[DUR. OF SEL CLIPS]</b> : Displays the total playback time of selected clips. <b>[TOTAL DURATION]</b> : Displays the total playback time of the displayed clip. • Factory setting: [NUM. OF CLIPS]

## Chapter 6 Menu Operations — Menu list

Item	Description of settings
[TEXT MEMO INDICATOR]	<p>Sets the display mode of the text memo indicator displayed for clips on the thumbnail screen.</p> <p><b>[ALL]:</b> Displays the indicator for all clips with text memos attached.</p> <p><b>[HIDE CARD SERIAL]:</b> Hides the text memo indicator for clips with only the following types of text memos attached.</p> <ul style="list-style-type: none"> <li>• Text memo with the serial number of card written</li> <li>• Other text memos for which offset is not set with clip metadata</li> </ul> <p>To record a text memo with the serial number of card written as metadata, set the main menu → [RECORDING SETUP] → [REC META DATA] → [CARD SERIAL] to [ON].</p> <p>Check [OFFSET] of [MEMO] on the clip properties screen to see whether offset is set for a text memo.</p> <ul style="list-style-type: none"> <li>• Factory setting: [ALL]</li> </ul>
[STORAGE COPY SETUP]	<p>Sets whether to verify or not when exporting in USB host mode.</p> <p><b>[ON]:</b> Verifies.</p> <p><b>[OFF]:</b> Does not verify.</p>

### [AUDIO SETUP]

Configure the settings regarding audio input/output.

Item	Description of settings
[INPUT SETTING]	
[INT MIC]	<p>Sets built-in microphone on/off and selects the directionality.</p> <p><b>[STEREO]:</b> Records audio from two directions in the front with the stereo microphone.</p> <p><b>[MONO]:</b> This mode records clearer audio from the front by enhancing the directionality forward like a shotgun microphone. Audio recorded on the left and right are the same.</p> <p><b>[OFF]:</b> Disables audio of the built-in stereo microphone.</p> <ul style="list-style-type: none"> <li>• Factory setting: [STEREO]</li> </ul>
[INPUT1 MIC LEVEL]	<p>Sets the level of an external microphone connected to the &lt;AUDIO INPUT 1&gt; terminal. Enabled only when a microphone is connected.</p> <p><b>[-40dB], [-50dB], [-60dB]</b></p> <ul style="list-style-type: none"> <li>• Factory setting: [-50dB]</li> </ul>
[INPUT2 MIC LEVEL]	<p>Sets the level of an external microphone connected to the &lt;AUDIO INPUT 2&gt; terminal. Enabled only when a microphone is connected.</p> <p><b>[-40dB], [-50dB], [-60dB]</b></p> <ul style="list-style-type: none"> <li>• Factory setting: [-50dB]</li> </ul>
[INPUT1 LINE LEVEL]	<p>Sets the level of an external line input to be connected to the &lt;AUDIO INPUT 1&gt; terminal. Enabled only for externally connected devices.</p> <p><b>[4dB], [0dB]</b></p> <ul style="list-style-type: none"> <li>• Factory setting: [0dB]</li> </ul>
[INPUT2 LINE LEVEL]	<p>Sets the level of an external line input to be connected to the &lt;AUDIO INPUT 2&gt; terminal. Enabled only for externally connected devices.</p> <p><b>[4dB], [0dB]</b></p> <ul style="list-style-type: none"> <li>• Factory setting: [0dB]</li> </ul>
[RECORDING CH SETTING]	
[FRONT VR SELECT]	<p>Sets the allocation to the &lt;F.AUDIO LEVEL&gt; dial. Enabled when the setting is other than &lt;AUTO&gt;. [0dB] to [-∞] can be adjusted.</p> <p><b>[CH1], [CH2], [CH3], [CH4], [CH1/CH2], [CH3/CH4], [ALL], [OFF]</b></p> <ul style="list-style-type: none"> <li>• Factory setting: [OFF]</li> </ul>
[AUTO LEVEL CH3]	<p>Selects the level setting method for audio channel 3.</p> <p><b>[ON]:</b> Sets the mode to adjust automatically. The limiter does not work.</p> <p><b>[OFF]:</b> The audio level follows the value for [LEVEL CONTROL CH3].</p> <ul style="list-style-type: none"> <li>• Factory setting: [ON]</li> </ul>
[AUTO LEVEL CH4]	<p>Selects the level setting method for audio channel 4.</p> <p><b>[ON]:</b> Sets the mode to adjust automatically. The limiter does not work.</p> <p><b>[OFF]:</b> The audio level follows the value for [LEVEL CONTROL CH4].</p> <ul style="list-style-type: none"> <li>• Factory setting: [ON]</li> </ul>
[LEVEL CONTROL CH3]	<p>Can be manually adjusted with this item when automatic level adjustment of audio channel 3 is [OFF].</p> <p><b>[0]...[100]</b></p> <ul style="list-style-type: none"> <li>• Factory setting: [70]</li> </ul>
[LEVEL CONTROL CH4]	<p>Can be manually adjusted with this item when automatic level adjustment of audio channel 4 is [OFF].</p> <p><b>[0]...[100]</b></p> <ul style="list-style-type: none"> <li>• Factory setting: [70]</li> </ul>
[MIC LOWCUT CH1]	<p>Enables/disables the lowcut filter for audio channel 1.</p> <p><b>[ON], [OFF]</b></p> <ul style="list-style-type: none"> <li>• Factory setting: [OFF]</li> </ul>
[MIC LOWCUT CH2]	<p>Enables/disables the lowcut filter for audio channel 2.</p> <p><b>[ON], [OFF]</b></p> <ul style="list-style-type: none"> <li>• Factory setting: [OFF]</li> </ul>
[MIC LOWCUT CH3]	<p>Enables/disables the lowcut filter for audio channel 3.</p> <p><b>[ON], [OFF]</b></p> <ul style="list-style-type: none"> <li>• Factory setting: [OFF]</li> </ul>
[MIC LOWCUT CH4]	<p>Enables/disables the lowcut filter for audio channel 4.</p> <p><b>[ON], [OFF]</b></p> <ul style="list-style-type: none"> <li>• Factory setting: [OFF]</li> </ul>
[LIMITER CH1]	<p>Enables/disables the limiter for audio channel 1.</p> <p><b>[ON], [OFF]</b></p> <ul style="list-style-type: none"> <li>• Factory setting: [OFF]</li> </ul>

## Chapter 6 Menu Operations — Menu list

Item	Description of settings
[LIMITER CH2]	Enables/disables the limiter for audio channel 2. <b>[ON], [OFF]</b> • Factory setting: [OFF]
[LIMITER CH3]	Enables/disables the limiter for audio channel 3. <b>[ON], [OFF]</b> • Factory setting: [OFF]
[LIMITER CH4]	Enables/disables the limiter for audio channel 4. <b>[ON], [OFF]</b> • Factory setting: [OFF]
[HEADROOM]	Sets the headroom (standard level). <b>[12dB], [18dB], [20dB]</b>
[OUTPUT SETTING]	
[AUDIO OUT]	Sets the audio signal output from the <AUDIO OUT> terminal, headphone terminal, <HDMI OUT>terminal, and built-in speaker. <b>[CH1/2], [CH1], [CH2], [CH3/4], [CH3], [CH4]</b> • Factory setting: [CH1/2]
[TEST TONE]	Outputs rated level 1 kHz tone signal according to the reference level. The standard level varies depending on the setting of [HEADROOM]. <b>[ON], [OFF]</b> • Factory setting: [ON]

### [OUTPUT SEL]

Configure the settings regarding video output from <SDI OUT>, <HDMI OUT>, <GENLOCK IN/VIDEO OUT>, or <TC IN/OUT> terminal.

Item	Description of settings
[SDI OUT]	Selects video output from the <SDI OUT> terminal. <b>[ON]:</b> Outputs video. <b>[OFF]:</b> Does not output video. • Factory setting: [OFF]
[SDI&HDMI SELECT]	Selects output signals from the <SDI OUT> terminal and <HDMI OUT> terminal. <b>[SYSTEM MODE]:</b> Follows the setting in [SYSTEM MODE] → [LINE&FREQ]. <b>[1080i]:</b> Converts into interlaced signals and outputs them when [1080-59.94P] or [1080-50P] is selected in [SYSTEM MODE] → [LINE&FREQ]. This cannot be selected when other settings are made. <b>[DOWNCON]:</b> Down converts to SD signal and outputs. • Factory setting: [SYSTEM MODE]
[3G-SDI OUT]	Selects 1080P signals of the HD SDI output in 1080P mode. <b>[LEVEL-A]:</b> Selects the LEVEL-A method. <b>[LEVEL-B]:</b> Selects the LEVEL-B DL method. • Factory setting: [LEVEL-B]
[SDI OUT CHAR]	Selects whether to superimpose characters on <SDI OUT> terminal output images. <b>[ON]:</b> Superimposes. <b>[OFF]:</b> Does not superimpose. • Factory setting: [OFF]
[SDI EDH]	Selects whether to superimpose EDH when output from the <SDI OUT> terminal is SD signal (480i and 576i). <b>[ON]:</b> Superimposes. <b>[OFF]:</b> Does not superimpose. • Factory setting: [ON]
[HD SDI REMOTE]	Sets whether to use the control function of recording operation for an external device (such as a recorder) connected to the <SDI OUT> terminal at HD SDI output. <b>[ON]:</b> Controls the recording operation of the external device. <b>[OFF]:</b> Does not control the recording operation of the external device. • Factory setting: [OFF]
[DOWNCON MODE]	Selects the mode of the down converter output signal mode from the <SDI OUT> or <GENLOCK IN/VIDEO OUT> terminal in HD mode (1080P, 1080i, or 720P). <b>[SIDE CROP], [LETTER BOX], [SQUEEZE]</b> • Factory setting: [LETTER BOX]
[DOWNCON SETTING]	
[DETAIL]	Turns detail function for the down converter output signal [ON]/[OFF]. <b>[ON], [OFF]</b> The down converter output signal contains detail components set during HD signal processing. This setting superimposes the detail components exclusive to down converter output to that signal. • Factory setting: [ON]
[H.DTL LEVEL]	Sets horizontal detail correction level for the down converter output signal. <b>[0]...[31]</b> • Factory setting: [8]
[V.DTL LEVEL]	Sets vertical detail correction level for the down converter output signal. <b>[0]...[31]</b> • Factory setting: [4]
[DTL CORING]	Sets the detail noise removal level. <b>[0]...[15]</b> • Factory setting: [1]
[H.DTL FREQ]	Selects the horizontal detail frequency. <b>[2.5MHz], [3MHz], [3.5MHz], [4MHz], [4.5MHz]</b> • Factory setting: [3.5MHz]

## Chapter 6 Menu Operations — Menu list

Item	Description of settings
[VIDEO OUT]	Selects the <GENLOCK IN/VIDEO OUT> terminal output [ON]/[OFF]. <b>[ON]</b> : Performs output. <b>[OFF]</b> : Stops output. • Factory setting: [OFF]
[VIDEO OUT CHAR]	Selects whether to superimpose characters on <GENLOCK IN/VIDEO OUT> terminal output images. <b>[ON]</b> : Superimposes. <b>[OFF]</b> : Does not superimpose. • Factory setting: [ON]
[VIDEO OUT ZEBRA]	Selects whether the zebra pattern is superimposed over the output video signals from the<GENLOCK IN/VIDEO OUT> terminal. <b>[ON]</b> : Superimposes. <b>[OFF]</b> : Does not superimpose. • Factory setting: [OFF]
[TC OUT]	Sets the type of time code output from the <TC IN/OUT> terminal. <b>[TCG]</b> : Outputs the time code generator value of the camera at all times. <b>[TCG/TCR]</b> : Outputs the time code generator value for camera image output, and the time code value of the video being played back for video playback output. • Factory setting: [TCG]
[TC OUTPUT REF]	Sets the output delay of time code output from the <TC IN/OUT> terminal. <b>[RECORDING]</b> : Outputs the recorded time code with no delay. This is used when performing simultaneous recording on two cameras with the time code of this camera as the master. <b>[VIDEO OUT]</b> : Matches to output images. • Factory setting: [VIDEO OUT]

### [NETWORK SETUP]

Configure the settings regarding the network.

Item	Description of settings										
[USB MODE SELECT]	Sets the camera operation mode when an external device is connected to the USB. <b>[STORAGE]</b> : Sets the mode to be used with connected devices such as an external hard disk drive. <b>[DEVICE]</b> : Selects the USB device mode for using P2 cards as mass storage, using computers or other devices connected via USB 2.0. • Factory setting: [STORAGE]										
[USB MODE]	Enables/disables the mode selected in [USB MODE SELECT]. <b>[ON]</b> , <b>[OFF]</b> • Factory setting: [OFF]										
[NETWORK SEL]	Sets the connection method when connecting the camera with an external device (such as a computer) via network. <b>[WLAN]</b> : Connects via wireless LAN. <b>[4G/LTE]</b> : Connects via 3G/4G/LTE. <b>[LAN]</b> : Connects via the <LAN> terminal. <b>[OFF]</b> : Does not connect. • Factory setting: [OFF]										
[NETWORK FUNC]	<table border="1" style="width: 100%; border-collapse: collapse;"> <tbody> <tr> <td style="width: 20%;">[HTTP SERVER]</td> <td>Configures the settings regarding the HTTP server.  <b>[BROWSE]</b>: Enables the P2 browser function.  <b>[BROWSE (+CTRL)]</b>: Enables the HTTP server function, starting and stopping recording at the terminal side, and preset control of time code or user bits.  <b>[DISABLE]</b>: HTTP Disables the server function.            • Factory setting: [DISABLE]</td> </tr> <tr> <td>[PLAYLIST]</td> <td>Sets entering/exiting of the playlist edit mode.  <b>[ON]</b>, <b>[OFF]</b>            • Factory setting: [OFF]</td> </tr> <tr> <td>[IP REMOTE]</td> <td>Sets the remote control function using an IP connection.  <b>[ENABLE]</b>: Enables remote control with IP connection.  <b>[DISABLE]</b>: Disables remote control with IP connection.            • Factory setting: [DISABLE]</td> </tr> <tr> <td>[USER ACCOUNT]</td> <td>Sets the user account name.</td> </tr> <tr> <td>[ACCOUNT LIST]</td> <td>Displays the currently set user account name. Registering of new accounts, deleting accounts, or changing password can also be performed.</td> </tr> </tbody> </table>	[HTTP SERVER]	Configures the settings regarding the HTTP server. <b>[BROWSE]</b> : Enables the P2 browser function. <b>[BROWSE (+CTRL)]</b> : Enables the HTTP server function, starting and stopping recording at the terminal side, and preset control of time code or user bits. <b>[DISABLE]</b> : HTTP Disables the server function. • Factory setting: [DISABLE]	[PLAYLIST]	Sets entering/exiting of the playlist edit mode. <b>[ON]</b> , <b>[OFF]</b> • Factory setting: [OFF]	[IP REMOTE]	Sets the remote control function using an IP connection. <b>[ENABLE]</b> : Enables remote control with IP connection. <b>[DISABLE]</b> : Disables remote control with IP connection. • Factory setting: [DISABLE]	[USER ACCOUNT]	Sets the user account name.	[ACCOUNT LIST]	Displays the currently set user account name. Registering of new accounts, deleting accounts, or changing password can also be performed.
[HTTP SERVER]	Configures the settings regarding the HTTP server. <b>[BROWSE]</b> : Enables the P2 browser function. <b>[BROWSE (+CTRL)]</b> : Enables the HTTP server function, starting and stopping recording at the terminal side, and preset control of time code or user bits. <b>[DISABLE]</b> : HTTP Disables the server function. • Factory setting: [DISABLE]										
[PLAYLIST]	Sets entering/exiting of the playlist edit mode. <b>[ON]</b> , <b>[OFF]</b> • Factory setting: [OFF]										
[IP REMOTE]	Sets the remote control function using an IP connection. <b>[ENABLE]</b> : Enables remote control with IP connection. <b>[DISABLE]</b> : Disables remote control with IP connection. • Factory setting: [DISABLE]										
[USER ACCOUNT]	Sets the user account name.										
[ACCOUNT LIST]	Displays the currently set user account name. Registering of new accounts, deleting accounts, or changing password can also be performed.										
[CLIENT SERVICE]	<table border="1" style="width: 100%; border-collapse: collapse;"> <tbody> <tr> <td style="width: 20%;">[FTP SETTING DATA]</td> <td>Sets the target from which the setting information of [CLIENT SERVICE] is acquired.  <b>[INTERNAL]</b>: Uses the setting value set on the camera.  <b>[SD CARD]</b>: Uses the setting information of the file inside the SD memory card inserted in the SD card slot.            When this item is set to [SD CARD], insert an SD memory card before turning on the power of the camera.            • Factory setting: [INTERNAL]</td> </tr> <tr> <td>• [FTP SERVER URL]</td> <td>Sets the name or address of the destination server.</td> </tr> <tr> <td>• [LOGIN USER]</td> <td>Sets the login user ID.</td> </tr> <tr> <td>• [LOGIN PASSWORD]</td> <td>Sets the login password.</td> </tr> <tr> <td>• [SSH]</td> <td>Sets when transferring files using SSH.  <b>[ENABLE]</b>: Uses SSH.  <b>[DISABLE]</b>: Does not use SSH.            • Factory setting: [DISABLE]</td> </tr> </tbody> </table>	[FTP SETTING DATA]	Sets the target from which the setting information of [CLIENT SERVICE] is acquired. <b>[INTERNAL]</b> : Uses the setting value set on the camera. <b>[SD CARD]</b> : Uses the setting information of the file inside the SD memory card inserted in the SD card slot. When this item is set to [SD CARD], insert an SD memory card before turning on the power of the camera. • Factory setting: [INTERNAL]	• [FTP SERVER URL]	Sets the name or address of the destination server.	• [LOGIN USER]	Sets the login user ID.	• [LOGIN PASSWORD]	Sets the login password.	• [SSH]	Sets when transferring files using SSH. <b>[ENABLE]</b> : Uses SSH. <b>[DISABLE]</b> : Does not use SSH. • Factory setting: [DISABLE]
[FTP SETTING DATA]	Sets the target from which the setting information of [CLIENT SERVICE] is acquired. <b>[INTERNAL]</b> : Uses the setting value set on the camera. <b>[SD CARD]</b> : Uses the setting information of the file inside the SD memory card inserted in the SD card slot. When this item is set to [SD CARD], insert an SD memory card before turning on the power of the camera. • Factory setting: [INTERNAL]										
• [FTP SERVER URL]	Sets the name or address of the destination server.										
• [LOGIN USER]	Sets the login user ID.										
• [LOGIN PASSWORD]	Sets the login password.										
• [SSH]	Sets when transferring files using SSH. <b>[ENABLE]</b> : Uses SSH. <b>[DISABLE]</b> : Does not use SSH. • Factory setting: [DISABLE]										

## Chapter 6 Menu Operations — Menu list

Item	Description of settings
[SSH PORT]	Sets the network port number when SSH is used. Set the same number as the server. The menu setting value is displayed with [*]. • Factory setting: [22]
[LOAD (SD CARD)]	Loads the setting information of client service from the SD memory card.
[SAVE (SD CARD)]	Saves the setting information of client service onto the SD memory card.
[REC DURING UPLOAD]	Sets whether to use the rec during upload function. <b>[ENABLE]</b> : Uses the rec during upload function. <b>[DISABLE]</b> : Does not use the rec during upload function. • Factory setting: [DISABLE]
[AUTO COPY]	Sets whether to enable the function to register clips recorded using the camera automatically to the upload list when recording stops, and if enabled, sets the type of target clip. <b>[REC CLIP(PROXY)]</b> : Upload target is proxy data of recorded clips. <b>[REC CLIP]</b> : Upload target is recorded clips (main recording data and proxy data). <b>[DISABLE]</b> : Does not automatically upload recorded clips. • Factory setting:[DISABLE]
[UPLOAD LIST]	Displays the list information of clips to upload.
[SAVE LOG (SD CARD)]	Save up to the latest 1000 logs for clip information (month and date, clip number (global clip ID), status) registered in the upload list to an SD memory card.
[LAN PROPERTY]	
[MAC ADDRESS]	Displays the MAC address of the <LAN> terminal on the camera. (Cannot be changed.)
[DHCP]	Sets whether to use automatic acquisition via DHCP. (Mutually exclusive with [DHCP SERVER] setting) <b>[ENABLE]</b> : Uses automatic acquisition. <b>[DISABLE]</b> : Does not use automatic acquisition. Set [IP ADDRESS], [SUBNET MASK], [DEFAULT GATEWAY], [PRIMARY DNS], and [SECONDARY DNS]. • Factory setting: [ENABLE]
[IP ADDRESS]	Sets the IP address when [DISABLE] is selected in [DHCP]. • Factory setting: [192.168.0.1]
[SUBNET MASK]	Sets the subnet mask when [DISABLE] is selected in [DHCP]. • Factory setting: [255.255.255.0]
[DEFAULT GATEWAY]	Sets the default gateway when [DISABLE] is selected in [DHCP]. • Factory setting: [192.168.0.254]
[PRIMARY DNS]	Sets the primary DNS server when [DISABLE] is selected in [DHCP]. • Factory setting: [0.0.0.0]
[SECONDARY DNS]	Sets the secondary DNS server when [DISABLE] is selected in [DHCP]. • Factory setting: [0.0.0.0]
[DHCP SERVER]	Sets whether to use the DHCP SERVER function when connected via wired LAN. (Mutually exclusive with [DHCP] setting) <b>[ENABLE]</b> : Uses the DHCP SERVER function. <b>[DISABLE]</b> : Does not use the DHCP SERVER function. • Factory setting: [DISABLE]
[WIRELESS PROPERTY]	
[MAC ADDRESS]	Displays the MAC address of the wireless LAN of the camera. (Cannot be changed.)
[TYPE]	Sets the connection method. <b>[DIRECT]</b> : Accesses to the network function of the camera directly from a smartphone, tablet, or computer. <b>[INFRA]</b> : Connects to the wireless access point. • Factory setting: [DIRECT]
[SSID INPUT MODE]	Sets the setting method of SSID. When [TYPE] in [WIRELESS PROPERTY] is set to [INFRA], this item can be set. <b>[SELECT]</b> : Selects from the access point list. <b>[MANUAL]</b> : For entering the access point manually. • Factory setting: [SELECT]
[SSID]	Displays network name (SSID).
[CHANNEL]	Sets the channels to be used when [DIRECT] is selected in [TYPE] and the camera is connected via wireless LAN. <b>[AUTO], [CH1], [CH6], [CH11]</b> • Factory setting: [AUTO]
[ENCRYPTION]	Sets the encryption format. <b>[WPA-TKIP], [WPA-AES], [WPA2-TKIP], [WPA2-AES]</b> • Factory setting: [WPA2-AES]
[ENCRYPT KEY]	Sets the encryption key. Set the key using a string of 8 to 63 characters or a hexadecimal number with 64 digits. • Factory setting: [01234567890123456789abcdef]
[DHCP]	Sets whether to use automatic acquisition via DHCP when [INFRA] is selected in [TYPE]. <b>[ENABLE]</b> : Uses automatic acquisition. <b>[DISABLE]</b> : Does not use automatic acquisition. Set [IP ADDRESS], [SUBNET MASK], [DEFAULT GATEWAY], [PRIMARY DNS], and [SECONDARY DNS]. • Factory setting: [ENABLE]
[IP ADDRESS]	Sets the IP address when [DISABLE] is selected in [DHCP]. • Factory setting: [192.168.0.1]
[SUBNET MASK]	Sets the subnet mask when [DISABLE] is selected in [DHCP]. • Factory setting: [255.255.255.0]
[DEFAULT GATEWAY]	Sets the default gateway when [INFRA] is selected in [TYPE] and [DISABLE] is selected in [DHCP]. • Factory setting: [192.168.0.254]

## Chapter 6 Menu Operations — Menu list

Item	Description of settings
[PRIMARY DNS]	Sets the primary DNS server when [INFRA] is selected in [TYPE] and [DISABLE] is selected in [DHCP], or when [ENABLE] is selected in [DHCP] and the primary DNS server cannot be obtained. • Factory setting: [0.0.0.0]
[SECONDARY DNS]	Sets the secondary DNS server when [INFRA] is selected in [TYPE] and [DISABLE] is selected in [DHCP], or when [ENABLE] is selected in [DHCP] and the primary DNS server cannot be obtained. • Factory setting: [0.0.0.0]
[DHCP SERVER]	Sets whether to use the DHCP SERVER function when [DIRECT] is selected in [TYPE] and the camera is connected via wireless LAN. <b>[ENABLE]</b> : Uses the DHCP SERVER function. <b>[DISABLE]</b> : Does not use the DHCP SERVER function. • Factory setting: [ENABLE]
[NETWORK TOOLS]	
[LOG DISPLAY]	Displays the connection log.
[STATUS DISPLAY]	Displays the network status.
[INITIALIZE]	Restores the network setting status to the factory settings.
[PING]	Checks network connection using PING commands.

### [DISPLAY SETUP]

Configure the settings regarding the details to be displayed on the viewfinder or LCD monitor.

These menu items cannot be set when the thumbnail screen is displayed.

Item	Description of settings
[MENU DISPLAY]	Selects the LCD monitor or the view finder as the location where the menu is displayed. <b>[LCD&amp;EVF]</b> : Displays the menu both on the LCD monitor and the viewfinder. <b>[LCD]</b> : Displays the menu only on the LCD monitor. • Factory setting: [LCD&EVF]
[ZEBRA1 DETECT]	Sets the extraction level of zebra pattern 1. <b>[0%]...[109%]</b> • Factory setting: [70%]
[ZEBRA2 DETECT]	Sets the extraction level of zebra pattern 2. <b>[0%]...[109%]</b> • Factory setting: [85%]
[ZEBRA2]	Sets on/off of zebra pattern 2 and selects the type. <b>[ON]</b> , <b>[SPOT]</b> , <b>[OFF]</b> • Factory setting: [SPOT]
[CENTER MARK]	Controls the center mark. <b>[1]</b> : + (large) <b>[2]</b> : Open center (large) <b>[3]</b> : + (small) <b>[4]</b> : Open center (small) <b>[OFF]</b> : Does not display. • Factory setting: [1]
[SAFETY MARK]	Selects the type of frame for the safety zone marker. <b>[1]</b> : Box <b>[2]</b> : Corners <b>[OFF]</b> : Does not display. • Factory setting: [2]
[SAFETY AREA]	Sets the size of the safety zone marker. The constant ratio of length to width can be set in 1% increments. <b>[80%]...[100%]</b> • Factory setting: [90%]
[FRAME MARK]	Enables/disables frame marker. <b>[ON]</b> , <b>[OFF]</b> • Factory setting: [OFF]
[FRAME SIG]	Sets frame marker aspect ratio. <b>[4:3]</b> , <b>[13:9]</b> , <b>[14:9]</b> , <b>[1.85:1]</b> , <b>[2.35:1]</b> • Factory setting: [4:3]
[FRAME LVL]	Sets the level of the outside of the frame marker. <b>[0]...[15]</b> • Factory setting: [15]
[LEVEL GAUGE]	Enables/disables level gauge. <b>[ON]</b> , <b>[OFF]</b> • Factory setting: [OFF]
[FOCUS BAR]	Displays/hides the focus bar indicating the degree of focus. <b>[ON]</b> , <b>[OFF]</b> • Factory setting: [OFF]
[ZOOM/FOCUS]	Selects the unit of zoom and focus values. <b>[NUMBER]</b> : Displays position values of zoom and focus from [0] to [99]. <b>[mm/feet]</b> : Zoom is displayed in units of millimeters, and focus in units of feet. <b>[mm/m]</b> : Zoom is displayed in units of millimeters, and focus in units of meters. <b>[OFF]</b> : Neither zoom nor focus is displayed. • Factory setting: [NUMBER]

## Chapter 6 Menu Operations — Menu list

Item	Description of settings
[LEVEL METER]	Displays/hides audio level meter. <b>[ON], [OFF]</b> • Factory setting: [ON]
[DATE/TIME]	Sets date and time display. <b>[TIME]</b> : Displays the hour, minute, and second. <b>[DATE]</b> : Displays the year, month, and date. <b>[TIME&amp;DATE]</b> : Displays the hour, minute, and second, as well as year, month, and date. <b>[OFF]</b> : Does not display. • Factory setting: [OFF]
[REC COUNTER]	Sets operation of the counter for recording. <b>[TOTAL]</b> : Performs continuous counting until it is reset using the <RESET> button. <b>[CLIP]</b> : Clears the counter value at the start of recording and counts the time for each recording. • Factory setting: [TOTAL]
[P2CARD REMAIN]	Turns display of the remaining recording capacity for the P2 card [ON]/[OFF]. <b>[ON], [OFF]</b> • Factory setting: [ON]
[BATTERY]	Turns the battery charge level indicator [ON]/[OFF]. <b>[ON], [OFF]</b> • Factory setting: [ON]
[OTHER DISPLAY]	Sets display details of other information. <b>[PARTIAL]</b> : Displays information partly. <b>[ALL]</b> : Displays all information. <b>[USER]</b> : Displays the information set in [DISPLAY SETTING]. • Factory setting: [PARTIAL]
[DISPLAY SETTING]	
[IRIS]	Displays/hides F value and auto iris control status. <b>[ON], [OFF]</b> • Factory setting: [ON]
[GAIN]	Displays/hides gain value. <b>[ON], [OFF]</b> • Factory setting: [ON]
[SHUTTER]	Displays/hides shutter speed. <b>[ON], [OFF]</b> • Factory setting: [ON]
[WHITE BALANCE]	Displays/hides the <WHITE BAL> switch position. <b>[ON], [OFF]</b> • Factory setting: [ON]
[ND]	Displays/hides the set value of ND filter. <b>[ON], [OFF]</b> • Factory setting: [ON]
[Y GET]	Displays/hides brightness of Y GET. <b>[ON], [OFF]</b> • Factory setting: [ON]
[D.ZOOM]	Displays/hides digital zoom display. <b>[ON], [OFF]</b> • Factory setting: [ON]
[SCENE FILE]	Displays/hides scene file name. <b>[ON], [OFF]</b> • Factory setting: [ON]
[DRS]	Toggles whether to display when the dynamic range stretcher function is activated. <b>[ON], [OFF]</b> • Factory setting: [ON]
[FBC]	Toggles whether to display when the flash band compensation function is activated. <b>[ON], [OFF]</b> • Factory setting: [ON]
[AREA]	Toggles whether to display when the area mode function is activated. <b>[ON], [OFF]</b> • Factory setting: [ON]
[OIS]	Displays/hides image stabilizer display. <b>[ON], [OFF]</b> • Factory setting: [ON]
[FULL AUTO]	Displays/hides the display when the <AUTO/MANUAL> switch is at <AUTO>. <b>[ON], [OFF]</b> • Factory setting: [ON]
[SHOOTING MODE]	Displays/hides high-sensitivity mode. <b>[ON], [OFF]</b> • Factory setting: [ON]
[PB MODE]	Displays/hides the operation status of playback. <b>[ON], [OFF]</b> • Factory setting: [ON]
[SYSTEM MODE]	Displays/hides system mode. <b>[ON], [OFF]</b> • Factory setting: [OFF]
[REC FORMAT]	Displays/hides recording format display. <b>[ON], [OFF]</b> • Factory setting: [ON]



## Chapter 6 Menu Operations — Menu list

Item	Description of settings
[FRAME RATE]	Displays/hides frame rate. <b>[ON], [OFF]</b> • Factory setting: [ON]
[ASPECT]	Displays/hides letterbox recording display. <b>[ON], [OFF]</b> • Factory setting: [ON]
[REC MEDIA]	Displays/hides recording media. <b>[ON], [OFF]</b> • Factory setting: [ON]
[ONE CLIP REC]	Displays/hides the status of one-clip recording mode. <b>[ON], [OFF]</b> • Factory setting: [ON]
[REC MODE]	Displays/hides simultaneous recording mode display. <b>[ON], [OFF]</b> • Factory setting: [ON]
[PROXY]	Displays/hides proxy information. <b>[ON], [OFF]</b> • Factory setting: [ON]
[GPS]	Displays/hides GPS signal reception status. <b>[ON], [OFF]</b> • Factory setting: [ON]
[EVF DETAIL]	Adjusts the contour of the video in the viewfinder or LCD monitor to make it easier to focus. <b>[ON], [OFF]</b> • Factory setting: [ON] If the function is assigned to the USER button, [ON]/[OFF] can be switched using the USER button.
[EVF PEAK LEVEL]	Adjusts the peaking level of the viewfinder and LCD monitor. [-7]...[7] • Factory setting: [0]
[EVF PEAK FREQ]	Adjusts the peaking frequency of the viewfinder and LCD monitor. <b>[HIGH], [LOW]</b> • Factory setting: [LOW]
[EVF SETTING]	
[EVF BRIGHTNESS]	Adjusts the brightness of the viewfinder. [-15]...[15] • Factory setting: [0]
[EVF CONTRAST]	Adjusts the contrast of the viewfinder. [-30]...[30] • Factory setting: [0]
[EVF COLOR LEVEL]	Adjusts the color level of the viewfinder. [-15]...[15] • Factory setting: [0]
[EVF COLOR]	Selects whether to display video in the viewfinder in color or in black and white. <b>[ON]</b> : Displays in color. <b>[OFF]</b> : Displays in black and white. • Factory setting: [ON]
[EYE SENSOR]	Selects sensitivity of eye sensor. <b>[HIGH], [LOW]</b> • Factory setting: [HIGH]
[LCD SETTING]	
[LCD BRIGHTNESS]	Adjusts the brightness of the LCD monitor. [-15]...[15] • Factory setting: [0]
[LCD CONTRAST]	Adjusts the contrast of the LCD monitor. [-30]...[30] • Factory setting: [0]
[LCD COLOR LEVEL]	Adjusts the color level of the LCD monitor. [-15]...[15] • Factory setting: [0]
[LCD BACKLIGHT]	Adjusts the brightness of the LCD monitor backlight. [1]...[-3] [1]: Brightens more than normal. [-3]: Becomes the darkest. • Factory setting: [0]
[SELF SHOOT]	Sets the display of the LCD monitor when mirror shooting is performed. <b>[NORMAL]</b> : Does not invert the left and right sides. <b>[MIRROR]</b> : Inverts the left and right sides. • Factory setting: [MIRROR]

### [CARD FUNCTIONS]

Configure the settings regarding reading/writing of the scene files and user files to SD memory cards.

Item	Description of settings
[SCENE FILE]	Loads scene files from an SD memory card or saves them to an SD memory card. <b>[LOAD]</b> : Loads scene files. <b>[SAVE]</b> : Saves scene files.



## Chapter 6 Menu Operations — Menu list

Item	Description of settings
[USER FILE]	Loads user files from an SD memory card or saves them to an SD memory card. [LOAD]: Loads user files. [SAVE]: Saves user files.
[SD CARD PROPERTY]	Displays the SD memory card status. The format condition, available space, etc. can be checked.
[FORMAT SD CARD]	Formats an SD memory card.

### [OTHER FUNCTIONS]

Configure these items to make settings for reading/writing, initialization of user file data on the internal memory, and the camera settings.

Item	Description of settings
[USER FILE]	Loads/saves/initializes user files on the camera memory. [LOAD]: Loads user files. [SAVE]: Saves user files. [INITIALIZE]: Restores user files to the factory settings.
[ACCESS LED]	Selects whether to light the access LED of the P2 card. [ON], [OFF] • Factory setting: [ON]
[TALLY LAMP]	Sets up the tally lamp lighting conditions. [FRONT]: The front tally lamp lights up. [REAR]: The rear tally lamp lights up. [BOTH]: Both the front and rear tally lamps light up. [OFF]: The tally lamp does not light up. • Factory setting: [OFF]
[CLOCK SETTING]	Sets the built-in calendar (date and time) and time zone.
[TIME ZONE]	For GMT, set using 30 minute intervals from -12:00 to +13:00 (however, +12:45 is possible). After setting the time, when changing the setting value for [TIME ZONE], the displayed and registered times switch to the time with the time difference.
[GL PHASE]	When in HD (1080i, 720P) mode, selects the output signal of phase to be locked to the signal input to the <GENLOCK IN/VIDEO OUT> terminal. [HD SDI]: Locks the HD SDI output signal to genlock input. [COMPOSITE]: Locks the down-converted composite output signals (signal from the <GENLOCK IN/VIDEO OUT> terminal and signal of 480i, 576i from the <SDI OUT>terminal) to genlock input. • Factory setting: [HD SDI]
[H PHASE]	Adjusts the horizontal phase when the phase is to be locked to the signal input to the <GENLOCK IN/VIDEO OUT> terminal. [-512]...[512] • Factory setting: [0]
[SEEK POS SEL]	Selects the position to move when the <▶▶▶>/<◀◀◀> button is pressed while playback is paused. [CLIP]: Top of the clip [CLIP&TEXT MEMO]: Top of the clip and text memo location • Factory setting: [CLIP]
[GPS]	Configures internal GPS settings. [ON]: Activates the GPS operation. Outputs the location information as a signal to the <SDI OUT> terminal and records it as clip metadata. [OFF]: Does not activate the GPS operation. Does not output and record the location information. • Factory setting: [OFF]
[P.OFF GPS DATA]	Retains the GPS location information when the camera is turned off. Sets whether to record the retained data at the next turning on until a positioning is performed. [HOLD]: Retains and records data. [CLEAR]: Clears the data at the time when the camera is turned off. Records 0 (No-Info) at the next turning on until a positioning is performed. • Factory setting: [CLEAR]
[MENU INITIALIZE]	Restores the whole setting menu including all scene files (1 to 6) and user files to the factory settings.

### [MAINTENANCE]

These are items for performing maintenance inspection of the camera. This menu is used for updating the firmware version of the camera.

Item	Description of settings
[UPDATE]	Performs an update of the camera firmware. (Enabled only when there is a dedicated update file on the SD memory card.)
[ACTIVATE]	This menu activates optional functions (separate fees required).

### [DIAGNOSTIC]

This menu is used to display the firmware version, product name, serial number, and operation time of the camera.

Item	Description of settings
[VERSION]	Displays the information of the camera. [MODEL NAME]: Displays the product name of the camera. [SERIAL NO.]: Displays the serial number of the camera. [MAC ADDRESS]: Displays the MAC address of the camera (Media Access Control address). [UID]: Displays the unique ID of the camera.
[OPERATION]	Displays the operation time of the camera.

## [USER MENU SEL]

Configure the items to be displayed in [USER MENU].

**[OPTION MENU] list****[AWB PRE CONTROL]**

Change the output display or output value for the white balance preset value [3200K].

Item	Description of settings
[R Gain]	Displays the output of Rch of preset [3200K]. The color can be changed on the Rch axis by changing the output of Rch. [-400]...[400] • Factory setting: [0]
[B Gain]	Displays the output of Bch of preset [3200K]. The color can be changed on the Bch axis by changing the output of Bch. [-400]...[400] • Factory setting: [0]
[G AXIS]	Displays the output of G axis of preset [3200K]. The color can be changed on the G axis by changing the output of Rch/Bch. [-400]...[400] • Factory setting: [0]

**[CAM REMOTE ADJ.]**

Configure settings when a remote control is used.

Item	Description of settings
[FOCUS ADJ.]	Adjusts the focus when the remote control is used. [-20]...[20] • Factory setting: [0]
[IRIS ADJ.]	Adjusts the iris when the remote control is used. [-20]...[20] • Factory setting: [0]
[ZOOM ADJ.]	Adjusts the zoom when the remote control is used. [-20]...[20] • Factory setting: [0]

**[ENG SECURITY]**

Select whether to place restrictions on opening and closing the menu screen.

**[ON]:** Disables opening of menu items other than [USER MENU]. To release, consult your dealer.

**[OFF]:** Opening and closing are not restricted.

## Chapter 7 **Display**

---

This chapter describes the screen displayed on the viewfinder or LCD monitor.

## Screen status display

In addition to video, the viewfinder and LCD monitor display messages that indicate the camera settings and operation status, a center marker, safety zone marker, zebra patterns, and other information.

### Configuration of status display on screen

The screen displayed in normal status is displayed as shown below.



### Selecting display items on screen

To select display items on the viewfinder or LCD monitor screen, switch [ON]/[OFF] or switch the type of the respective item in the main menu → [DISPLAY SETUP].

For details, refer to “Setting menu basic operations” (page 124).

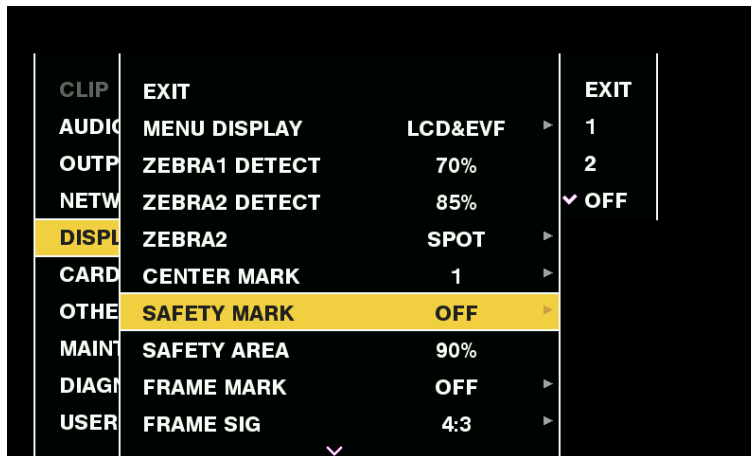

### Displaying screen

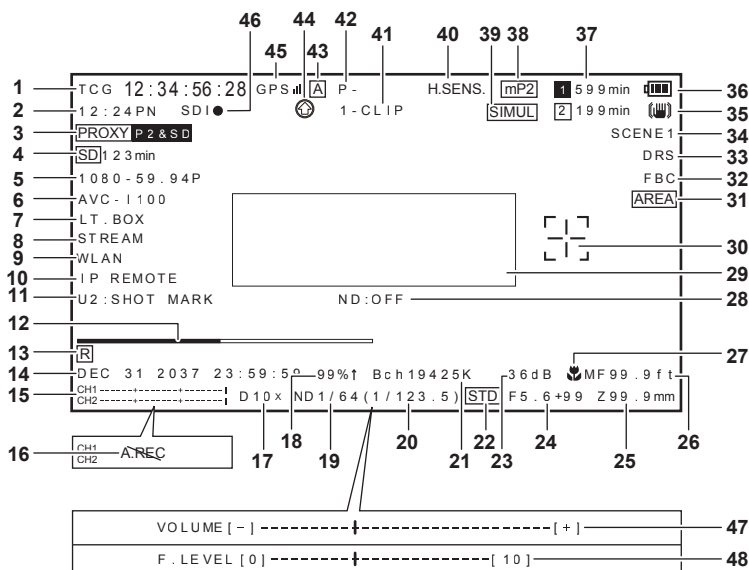

#### 1 Time code display

Every press of the <COUNTER> button switches to the next data (or no display).

- Counter: Counter value

- [CLIP]: Clip counter value (recording mode only)  
Clip counter value for each recording  
Displayed when [CLIP] is set in the main menu → [DISPLAY SETUP] → [REC COUNTER].
- [TCG]: Time code value  
When operating in drop frame mode, the “:” (colon) mark between the second and frame changes to “.” (dot).  
During playback, [TCR] is displayed.
- [UBG]: User bits value  
During playback, [UBR] is displayed.
- [VUBG]: User bits value of VITC  
During playback, [VUBR] is displayed.

 **NOTE**

- For [TCG] and [UBG], if they are locked to the input signal from the <TC IN/OUT> terminal, [TCG] and [UBG] are displayed in white letters with outlines.
- The time code during playback with 24PN is displayed converted into 30 frames.

**2 Shooting/recording and playback frame rate display**

For variable frame rate recording, the number of frames for shooting and the number of frames for recording/playback are displayed.

Example) 60:24PN (variable frame rate in 60P shooting, 24PN recording)

For playback, 2:3 pull-down is performed to make the video 24P over 60P, and playback in 24/60 times speed is indicated.

For standard recording, only the shooting frame rate is displayed.

**3 Proxy information display**

Displays the proxy recording information.

- [PROXY P2 (P2&SD)]: Displayed when proxy recording is started.
- [PROXY ERR]: Displayed when there is an error in proxy recording.

**4 SD memory card status display**

- [WP]: Write protected
- [END]: No remaining free space
- [WR ERR]: Write error
- [SD \*\*\*min]: The remaining free space is displayed when proxy is recorded to an SD memory card. (Displayed only in the regular mode check.)  
Flashing when the remaining capacity is one minute or less. [—min] is displayed when there is no SD memory card.

**5 System mode display**

Displays the mode in which the camera is operating.

- [1080-59.94P]: 1080/59.94 progressive mode
- [1080-59.94i]: 1080/59.94 interlaced mode
- [1080-50P]: 1080/50 progressive mode
- [1080-50i]: 1080/50 interlaced mode
- [1080-23.98PsF]: 1080/23.98PsF progressive/segment frame mode
- [720-59.94P]: 720/59.94 progressive mode
- [720-50P]: 720/50 progressive mode
- [480-59.94i]: 480/59.94 interlaced mode
- [576-50i]: 576/50 interlaced mode

**6 Recording format display**

Displays the recording method.

- [AVC-I200]
- [AVC-I100]
- [AVC-I50]
- [AVC-G50]
- [AVC-G25]
- [AVC-G12]
- [DVCPRO HD]
- [DVCPRO50]
- [DVCPRO]
- [DV]

**7 Letterbox recording display**

Displayed while letterbox recording is performed when the recording format is 480i/576i and [LETTER BOX] is set in the main menu → [SYSTEM MODE] → [ASPECT CONV].

**8 Streaming mode status display**

Displays the streaming status during streaming operation.

- [STREAM]: Displayed when operating properly.
- [STRMERRR]: Displayed when not operating properly.

**9 Network mode status display**

Displays the status of the network function.

Displayed only when the <DISP/MODE CHK> switch is pushed towards the <CHK> side.

- [WLAN]: When the wireless LAN is connected (link state)
- [WLAN ]: When the wireless LAN is not connected (unlinked state)
- [WLANERRR]: When there is a problem with the wireless LAN connection
- [LAN]: When the wired LAN is connected (link state)

- [LAN $\square$ ]: When the wired LAN is not connected (unlinked state), or when there is a problem
- No display: When the network function is disabled

**10 Remote control display in an IP connection**

The remote control status in an IP connection is displayed when [IP REMOTE] is set to [ENABLE] in the main menu → [NETWORK SETUP] → [NETWORK FUNC].

[IP REMOTE] (flashing): Displayed during connection waiting status in an IP connection.

[IP REMOTE] (illuminated): Displayed when remote control is possible in an IP connection.

**11 USER button information display**

When the USER button is pressed, “USER button name: assigned function name” is displayed for three seconds. The USER button name is indicated by [U1] to [U8].

**12 Focus bar display**

Displays the following items in the bottom left of the viewfinder. The high-frequency component of the video is displayed in a numerical value.



- White bar: Focus bar display
- Green line: Peak display

**13 Time stamp recording display**

Displays [R] when time stamp recording is set.

**14 Date and time display**

Displayed in the order of “dd mmm yyyy hh:mm:ss”.

- mmm: Month (JAN (January), FEB (February), MAR (March), APR (April), MAY (May), JUN (June), JUL (July), AUG (August), SEP (September), OCT (October), NOV (November), DEC (December))
- dd: Date
- yyyy: Year (2000 to 2037)
- hh: Hour
- mm: Minute
- ss: Second

**15 Audio level meter display**

Switches between level meter display and audio output channels 1/2 and 3/4 while holding down the USER button where [AUDIO MON SEL] is assigned.

**16 Audio recording not possible display**

Displayed when audio recording is not possible during variable frame rate mode native recording, interval recording, or one shot recording.

**17 Digital zoom display**

Displays the digital zoom ratio.

- [D2×]: two times
- [D5×]: five times
- [D10×]: ten times

**18 Y GET brightness display**

In the Y GET mode, the image level in the frame displayed near the center of the screen is displayed as 0% to 109%.

**19 ND filter display**

Displays the selected ND filter.

**20 Shutter speed display**

Displays the shutter speed. When synchro scan is performed, the display shows the content set in the main menu → [SCENE FILE] → [SYNC SCAN TYPE] (time (minutes) or open angle image).

**21 <WHITE BAL> switch position display**

Displays the position currently selected. Also, the white balance operation is indicated when the automatic white balance is preset. In auto tracking white balance (white balance with automatic tracking) mode, [ATW] is indicated, and when auto tracking white balance mode is locked, [LOCK] is indicated.

**22 Auto iris control display**

- [STD]: Standard auto iris control
- [SPOT]: Auto iris control for spotlighting
- [BACK]: Auto iris control for the backlight compensation

**23 Gain display**

Displays the gain value of the image amplifier configured.

**24 Iris display**

Displays the F value.

**25 Zoom position display**

Displays the zoom position with [Z000] (maximum wide angle) to [Z999] (maximum telephoto). Change the unit to millimeters in the main menu → [DISPLAY SETUP] → [ZOOM/FOCUS].

 **NOTE**

- When the USER button where [FAST ZOOM] is assigned is pressed to switch the status, [Z] is displayed in white letter with outline.

## 26 Focus control information display

Displays the focus control information with [99] to [00]. [AF] is indicated for auto focus, and [MF] is indicated for manual focus. Also, when [MF ASSIST] is set to [ON] in the main menu → [SW MODE] while in manual focus mode, [MA] is indicated.

[95] (distance to the subject: infinity) to [00] (distance to the subject: approx. 5 cm)

Depending on the zoom position, the subject may not be within the macro range.

Also, depending on the zoom position, the lowest value of the macro range may vary. The display unit can be changed to feet or meters from the main menu → [DISPLAY SETUP] → [ZOOM/FOCUS].

While macro shooting is performed, [AF] or [MF] will be displayed in black and white reversal.

## 27 Macro display

Displayed when you have enabled the macro focus function using the <MACRO> button.

## 28 Recommended ND filter display

Displays the ND filter recommended for the current shooting conditions.

## 29 Camera warning, notification display area (pages 195, 155)

## 30 Area frame display

Displayed when the control stick is pressed when the function is assigned in the main menu → [SW MODE] → [AREA MODE].

## 31 Area display

Displayed when in area mode.

## 32 Flash band compensation function display

Displayed when the flash band compensation function is activated.

## 33 Dynamic range stretcher function display

Displayed when the dynamic range stretcher function is working.

## 34 Scene file name display



Indicates the scene file name [F1:] to [F6:].

## 35 Image stabilization display

Displayed when the <OIS> button is pressed and the image stabilizer mode has been set.

## 36 Battery charge level indicator

As the battery level decreases, the indication changes .

When the battery runs out,  (  ) flashes.

(When the camera is running on the AC adaptor,  is displayed.)

The battery charge level may not be indicated correctly in a place where the temperature is extremely low or high, or when the camera has not been used for a long period of time. To display the remaining battery level correctly, fully charge the battery, use the camera until the battery runs out, and then charge again. (Even after performing the procedure, the remaining battery may not be indicated correctly if the battery is used under extremely low or high temperature for a long period of time or if the battery has been repeatedly recharged.)

Note that the time in the battery charge level indicator is an approximate estimate as it changes according to the conditions of use.

## 37 P2 card remaining free space

- : This is the slot No. This is displayed in black and white inversion when the slot No. is recording destination. It flashes while the card is being recognized.
- [\*\*\*min]: Displays the remaining space on the media in each slot. During a near end, it flashes.
- (No display): Not displayed when a card is not inserted.
- [END]: Displayed when there is no space remaining on each card.
- [WP]: Displayed when the P2 card is write-protected.
- [ERR]: Displayed in case of format errors or authentication errors.
- [LOOP \*\*\*min]: Displayed when the loop recording mode is set. During the mode check, the second line displays the standard recording time of loop recording. [LOOP] flashes when loop recording is not possible, for example, when there is no more space remaining on the microP2 memory card.

## 38 Recording media display

Among P2 and microP2 memory card slots, displays the slot that can perform recording and playback operations set in the main menu → [RECORDING SETUP] → [REC MEDIA].

- [mP2]: microP2 memory card slot
- [P2]: P2 memory card slot

## 39 Simultaneous recording mode display, background recording mode display

- [SIMUL]: Displayed when the simultaneous recording is set. When the simultaneous recording cannot be performed, [SIMUL] indication is displayed with a diagonal line.
- [BACKGR]: Displayed when the camera is in the background recording mode and background recording is being performed on slot 2. When background recording has not started on slot 2, the [BACKGR] indication is displayed with a diagonal line.









## 40 High-sensitivity mode display

Displayed when [HIGH SENS.] is set in the main menu → [SYSTEM MODE] → [SHOOTING MODE].

## 41 One clip recording mode status display

- [1-CLIP]: The status where a new clip is to be recorded in one-clip recording
- [1\*CLIP]: The status where recording can be performed by combining to the previous clip in one-clip recording

## 42 Recording/playback operation status display

- [REC]\*1: Recording
- [PAUSE]: Recording standby
- : Playback pause
- : Playback
-  (  ): Frame-by-frame playback (frame-by-frame rewind)
-  (  ): Fast-forwarding/fast-forward playback (fast-reversing/fast-reverse playback)
-  (  ): Clip forwarding (clip rewinding), cueing up by clips



- [CLIP&T] ( [CLIP&T] ): Cueing up (rewinding) by clip and text memo (when [CLIP&TEXT MEMO] is set in the main menu → [OTHER FUNCTIONS] → [SEEK POS SEL])
  - [START]\*1: Displayed when recording of a new clip is started in one-clip recording.
  - [END]\*1: Displayed when combining of clips is ended in one-clip recording.
  - [L-]\*2: Loop recording
  - [I-]\*2: Interval recording, one-shot recording
  - [P-]\*2: Pre-recording
- \*1 If the display is set to [OFF], only [REC], [START], and [END] are displayed. Also, when pre-recording, loop recording, interval recording, or one-shot recording is set, it is displayed.
- \*2 Displayed when [INTERVAL], [ONE SHOT], or [LOOP] is set in the main menu → [RECORDING SETUP] → [RECORDING], or when [ON] is set in the main menu → [RECORDING SETUP] → [PRE REC].

**43 <AUTO/MANUAL> switch operation display**

Displayed when the <AUTO/MANUAL> switch is set to <AUTO>.

**44 Rec during upload function status display**

Displays the status of rec during upload.

- [ ]: Displayed until upload starts.
- [ ]: Displayed during upload.
- [ ]: Displayed from when transfer error occurred during upload until when the next upload starts.

**45 GPS display**

Displays the strength of the GPS signal reception in four levels. The GPS signal strength is indicated by the number of vertical bars. It is not displayed when GPS is disabled.

**46 HD SDI REMOTE recording status and 4G/LTE connection status**

Displays the control status of whether recording has started or stopped for an external device which is connected to the <SDI OUT> terminal. When set the main menu → [OUTPUT SEL] → [HD SDI REMOTE] to [ON], the status will always be displayed regardless of the setting in the main menu → [DISPLAY SETUP].

- [SDI ]: Status where the recording is being instructed for an external device
- [SDI ]: Status where recording stop is being instructed for an external device

Displays the 4G/LTE connection status. Displays at the 4G/LTE connection. Displays the strength of the signal reception in six levels. Displays the radio wave strength with the number of vertical bars. It is not displayed when the setting of 4G/LTE is disabled.

- [4G/LTE ]: During 4G/LTE connection
- [4G/LTE ]: When not connected with 4G/LTE
- [4G/LTE ]: When there is a problem with the 4G/LTE connection

**NOTE**

• Depending on the USB modem that is supported, vertical bars that indicate the signal strength may not be displayed.

**47 Audio monitor volume adjustment display**

Displayed when the <AUDIO MON/ADV> button is pressed for volume adjustment of speaker or headphones. The display disappears three seconds after the operation.

**48 Front audio level volume display**

The volume is displayed for three seconds when it is adjusted with the <F.AUDIO LEVEL> dial.

**Camera status display**

These are indicated in the information display area in the center.

- [ABB]: Displayed while automatic black balance operation is active.
- [ATW ACTIVE]: Displayed when the <AWB> button is pressed while auto tracking white balance is active.
- [ATW]/[ATW LOCK]: Displayed when the <WHITE BAL> switch is turned to <B> if [ATW] is allocated.
- [AWB]: Displayed while automatic white balance operation is active.
- [AWB P3200K]/[AWB P5600K]: When the <WHITE BAL> switch is at <PRST> position, displays the color temperature assigned to <PRST>. It is also displayed when you attempt to perform automatic white balance with the switch at <PRST> position.
- [BACK LIGHT]: Displayed when pressing the USER button to which [BACK LIGHT] is allocated for iris control and switching the status.
- [GAIN\*\*dB]: Displayed when gain is switched.
- [IRIS:MANUAL]/[IRIS:AUTO]: Displayed when you switch the iris operation.
- [SHUTTER 1/\*\* \*\*]/[SHUTTER OFF]: Displayed when you switch the shutter speed.
- [SPOT LIGHT]: Displayed when pressing the USER button to which [SPOT LIGHT] is allocated for iris control, and switching the status.

**Checking and displaying shooting status**

Also, the mode check [STATUS] screen is displayed when the <DISP/MODE CHK> switch is pushed towards the <CHK> side. During mode check, almost all items are displayed including usually hidden items so that the shooting status can be checked. For details on the mode check, refer to “Mode check display” (page 157).

The list shows the display/hidden status of each item in the [STATUS] screen. The display/hidden status differ depending on the <DISP/MODE CHK> switch settings and settings in the main menu → [DISPLAY SETUP] → [OTHER DISPLAY].

- “✓” indicates displaying, and “—” indicates hiding.
- [ON]/[OFF] for each item can be selected in the main menu → [DISPLAY SETUP] → [DISPLAY SETTING].

No	Item	Shooting	Playback	<DISP/MODE CHK>: <CHK>	<DISP/MODE CHK>: <OFF>	<DISP/MODE CHK>: <ON>		
						[OTHER DISPLAY]		
						[ALL]	[PARTIAL]	[USER]
1	Time code display	✓	✓	—*1	—*1	—*1	—*1	—*1

Chapter 7 Display — Screen status display

No	Item	Shooting	Playback	<DISP/ MODE CHK>: <CHK>	<DISP/MODE CHK>: <OFF>	<DISP/MODE CHK>: <ON>		
						[OTHER DISPLAY]		
						[ALL]	[PARTIAL]	[USER]
2	Shooting/recording and playback frame rate display	✓	✓	✓	—	✓	✓	✓
3	Proxy information display	✓	—	✓	—*2	—*1	—*1	✓
4	SD memory card status display	✓	—	✓	—*2	✓	✓	✓
5	System mode display	✓	✓	✓	—	✓	—	✓
6	Recording format display	✓	✓	✓	—	✓	—	✓
7	Letterbox recording display	✓	—	✓	—	✓	—	✓
8	Streaming mode status display	✓	—	✓	—	—	—	—
9	Network information display	✓	—	✓	—	—	—	—
10	Remote control display in an IP connection	✓	—	✓	—	—	—	—
11	USER button information display	✓	—	—*1	—*1	—*1	—*1	—*1
12	Focus bar display	✓	—	—*1	—*1	—*1	—*1	—*1
13	Time stamp recording display	✓	—	✓	—	—*1	—*1	—*1
14	Date and time display	✓	—	✓	—	—*1	—*1	—*1
15	Audio level meter display	✓	✓	✓	—	—*1	—*1	—*1
16	Audio recording not possible display	✓	—	✓	—	—*1	—*1	—*1
17	Digital zoom display	✓	—	✓	—	✓	✓	✓
18	Y GET brightness display	✓	—	✓	—	✓	✓	✓
19	ND filter display	✓	—	✓	—	✓	—	✓
20	Shutter speed display	✓	—	✓	—	✓	✓	✓
21	<WHITE BAL> switch position display	✓	—	✓	—	✓	✓	✓
22	Auto iris control display	✓	—	✓	—	✓	✓	✓
23	Gain display	✓	—	✓	—	✓	✓	✓
24	Iris display	✓	—	✓	—	✓	✓	✓
25	Zoom position display	✓	—	✓	—	—*1	—*1	—*1
26	Focus control information display	✓	—	✓	—	—*1	—*1	—*1
27	Macro display	✓	—	✓	—	✓	✓	✓
28	Recommended ND filter display	✓	—	✓	—	✓	—	✓
29	Camera warning, notification display area	✓	✓	✓	✓	✓	✓	✓
30	Area frame display	✓	—	—*1	—*1	—*1	—*1	—*1
31	Area display	✓	—	✓	—	✓	✓	✓
32	Flash band compensation function display	✓	—	✓	—	✓	✓	✓
33	Dynamic range stretcher function display	✓	—	✓	—	✓	✓	✓
34	Scene file name display	✓	—	✓	—	✓	—	✓
35	Image stabilization display	✓	—	✓	—	✓	✓	✓
36	Battery charge level indicator	✓	✓	✓	—*2	—*1	—*1	—*1
37	P2 card remaining free space	✓	✓	✓	—*2	—*1	—*1	—*1
38	Recording media display	✓	—	✓	—	✓	✓	✓
39	Simultaneous recording mode display	✓	—	✓	—	✓	—	✓
	Background recording mode display	✓	—	✓	—	✓	✓	✓
40	High-sensitivity mode display	✓	—	✓	—	✓	✓	✓
41	One clip recording mode status display	✓	—	✓	—	✓	✓	✓
42	Recording/playback operation status display	✓	✓	✓	—*3	✓	✓	✓
43	<AUTO/MANUAL> switch operation display	✓	—	✓	—	✓	✓	✓
44	Rec during upload function status display	✓	✓	—	—	—	—	—
45	GPS display	✓	—	✓	—	✓	—	✓
46	HD SDI REMOTE recording status and 4G/LTE connection status display	✓*4	—	✓*4	—	✓*4	✓*4	✓*4
47	Audio monitor volume adjustment display	✓	✓	—*1	—*1	—*1	—*1	—*1
48	Front audio level volume display	✓	—	—*1	—*1	—*1	—*1	—*1

\*1 May be displayed depending on other settings.

\*2 Displayed when the remaining capacity becomes smaller.

\*3 Displayed during shooting.

\*4 Always displayed when [HD SDI REMOTE] is set or when 4G/LTE connection is set.

## Mode check display

The camera settings and status can be displayed on the viewfinder or LCD monitor screen for check.

Each time the <DISP/MODE CHK> switch on the camera is pushed towards the <CHK> side, the five screens are switched.

[STATUS] screen display → [FUNCTION] screen display → [AUDIO] screen display → [USER SW] screen display → [META INFO] screen display → no display

Each screen is displayed for approximately five seconds. Pushing the <DISP/MODE CHK> switch towards the <CHK> side while the screen is displayed moves to the next screen.

### [FUNCTION] screen

Displays the video output status and information of the recording media.

[SDI OUT]	—	Displays the status of the signal output from the <SDI OUT> terminal.
	[TYPE]	Displays the format of the signal output from the <SDI OUT> terminal by [HD-SDI]/[SD-SDI].
	[CHAR]	Displays the superimposition status of characters selected in the main menu → [OUTPUT SEL] → [SDI OUT CHAR] by [ON]/[OFF].
[P2CARD STATUS]	—	Displays the status of the P2 card inserted in the card slot, remaining capacity, and total used capacity. The statuses of cards to be displayed are as follows: [ACTIVE]/[ACCESSING]/[INFO READING]/[FULL]/[PROTECTED]/[NOT SUPPORTED]/[FORMAT ERROR]/[AUTH NG]/[REC IMPOSSIBLE]/[NO CARD] For details, refer to “P2 card access LEDs and status of P2 cards” (page 34).
	[TOTAL P2/mP2]	Displays the remaining capacity/total capacity totaled for slots 1 and 2 (or slots 3) and the recording media ([P2] or [mP2]).
	[SLOT1]	Displays the status of the microP2 memory card in slot 1 and remaining capacity/total capacity.
	[SLOT2]	Displays the status of the microP2 memory card in slot 2 and remaining capacity/total capacity.
	[SLOT3]	Displays the status of the P2 memory card in slot 3 and remaining capacity/total capacity.
[PROXY]	[MEDIA]	Displays the media selection status for proxy recording. [P2]/[P2&SD]/[OFF]
	[MODE]	Displays the setting status for proxy recording mode. [AVC-G6 2CH MOV]/[SHQ 2CH MOV]/[HQ 2CH MOV]/[LOW 2CH MOV]
	[PROXY ERROR]	Displays the operation error on the proxy module.
[NETWORK]	[NETWORK]	Displays the status of network to be used and streaming status.

### [AUDIO] screen

Displays audio settings and the selection status of each recording channel.

[AUDIO]	[INT MIC]	Displays the built-in microphone status set in the main menu → [AUDIO SETUP] → [INPUT SETTING] → [INT MIC]. • [STEREO]: Records audio from two directions in the front with the 2ch stereo microphone. • [MONO]: This mode records clearer audio from the front by enhancing the directionality forward like a shotgun microphone. Audio recorded on the left and right are the same. • [OFF]: Disables audio of the built-in microphone.
	[AUDIO OUT]	Displays the audio input signal status set in the main menu → [AUDIO SETUP] → [OUTPUT SETTING] → [AUDIO OUT]. [CH1/CH2]/[CH1]/[CH2]/[CH3/CH4]/[CH3]/[CH4]
[A.IN]	[CH1/2/3/4]	Displays the input status of each channel. [INT(L)]/[INT(R)]/[INPUT1]/[INPUT2]
[LEVEL]	[CH1/2/3/4]	Displays the recording level adjustment method currently selected on each channel. • [VR]: Displayed when manual adjustment using the adjustment dial is set. • [MENU]: Displayed when manual adjustment using [LEVEL CONTROL CH3]/[LEVEL CONTROL CH4] is set in the main menu → [AUDIO SETUP] → [RECORDING CH SETTING]. • [AUTO]: Displayed when automatic adjustment is set.
[F.VR]	[CH1/2/3/4]	Displays by [ON]/[OFF] whether the <F.AUDIO LEVEL> dial is enabled on the channel to which [VR] (manual adjustment by adjustment dial) is displayed in [LEVEL].
[LIMITER]	[CH1/2/3/4]	Displays the limiter settings of each channel.
[LOWCUT]	[CH1/2/3/4]	Displays the lowcut filter status of each channel.

**[USER SW] screen**

Displays the assignment status of each USER button. For details, refer to “Assigning functions to the USER buttons” (page 37).

[OTHER ASSIGN]	[GAIN L]	Displays the gain value assigned to <L> of the <GAIN> switch.
	[GAIN M]	Displays the gain value assigned to <M> of the <GAIN> switch.
	[GAIN H]	Displays the gain value assigned to <H> of the <GAIN> switch.
	[S.GAIN]	Enumerates and displays the gain value assigned as super gain.
	[WHITE BAL A]	Displays the color temperature assigned to <A> of the <WHITE BAL> switch.
	[WHITE BAL B]	Displays the color temperature assigned to <B> of the <WHITE BAL> switch.
	[WHITE BAL PRE]	Displays the color temperature assigned to <PRST> of the <WHITE BAL> switch.
[USER SW]	[USER1] to [USER8]	Displays the assignment to the USER1 to USER8 buttons.

**[META INFO] screen**

Display the information added as metadata.

[META INFO]	[POSITION]	Displays information (latitude, longitude, altitude, date and time) acquired by GPS.
	[ROLL]	Displays the horizontal inclination of the camera acquired by the level gauge as an angle. Setting the horizontal position as 0°, inclination to the left is indicated as a minus value, and inclination to the right is indicated as a plus value.
	[PITCH]	Displays the vertical inclination of the camera acquired by the level gauge as an angle. Setting the vertical position as 0°, downward inclination is indicated as a minus value, and upward inclination is indicated as a plus value.

## Chapter 8 **Connecting to External Devices**

---

This chapter describes the external devices that can be connected to the camera.

## Connecting with headphones, remote control, or TV/monitor

### Headphones

Headphones (optional) can be connected to the headphone terminal (3.5 mm stereo mini jack).

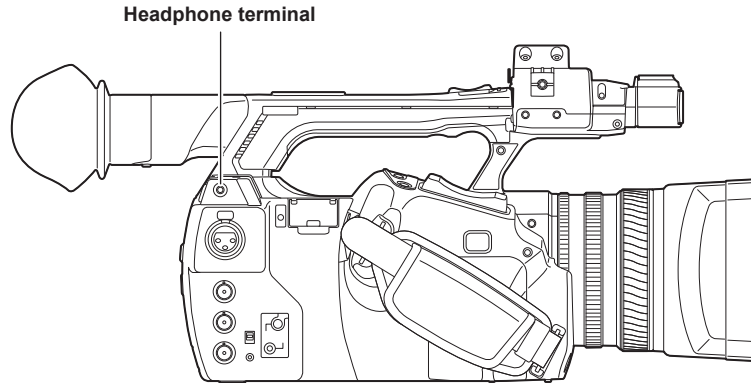

#### NOTE

- When headphones are connected, audio is not output from the speaker.

### Remote control

Remote control (optional) can be connected to the <CAM REMOTE> terminals (<FOCUS IRIS>, <ZOOM S/S>).

When the remote control is connected to the <FOCUS IRIS> terminal (3.5 mm mini jack), you can remotely control the focus and iris operations.

When the remote control is connected to the <ZOOM S/S> terminal (2.5 mm super mini jack), you can remotely control the zoom and recording start/stop operations.

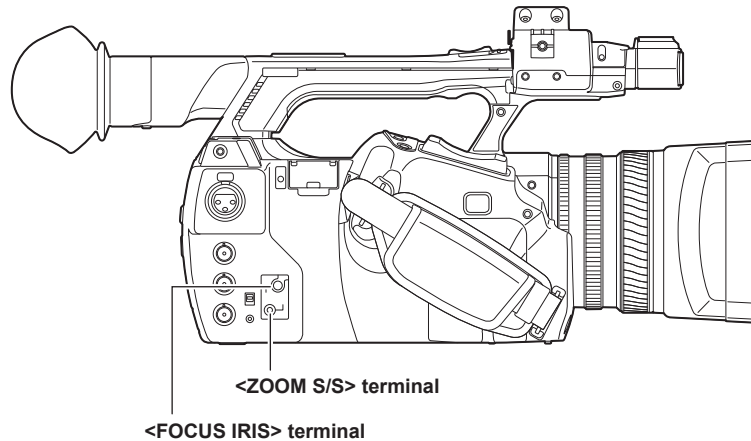

#### NOTE

- Do not connect a device other than a remote control to the <CAM REMOTE> terminals. Connecting a device other than a remote control may change the brightness or cause defocus of images.
- <AUTO>/<MANUAL> can be switched with the remote control, when the iris is adjusted by the remote control with the <AUTO/MANUAL> switch set to <AUTO> and [A.IRIS] is set to [OFF] from the main menu → [AUTO SW].
- When the remote control is connected to the <FOCUS IRIS> terminal, iris can be adjusted only by the remote control and cannot be adjusted by the iris ring on the camera.

### TV/monitor

A TV or monitor can be connected as shown in the following figure.

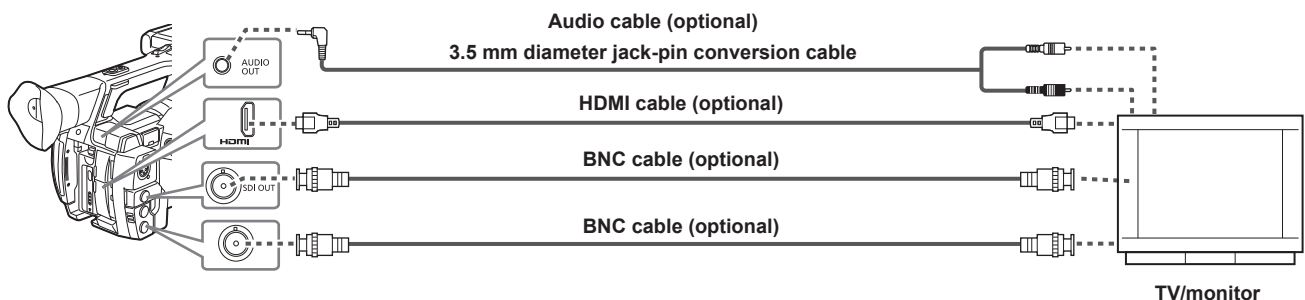

 **NOTE**

- VIERA Link is not supported on the camera. Please be aware that when using an HDMI cable and connecting this camera to a device that supports VIERA Link, the VIERA Link of other devices may not work in some cases.
- SD signals (480i, 576i) output from the <HDMI OUT> terminal are converted to progressive signals (480P, 576P) then output.
- For the BNC cable (optional) connected to the <SDI OUT> terminal, prepare a double-shielded cable equivalent to 5C-FB.
- Prepare the HDMI cable (optional) with double shielded. For the HDMI cable, using Panasonic HDMI cable is recommended.

## Connection function via <USB2.0 DEVICE> or <USB3.0 HOST> terminal

### Connecting to a computer in the USB device mode

By connecting the camera to a computer via USB 2.0, the P2 card inserted in the camera can be used as mass storage.

#### Connecting to a computer

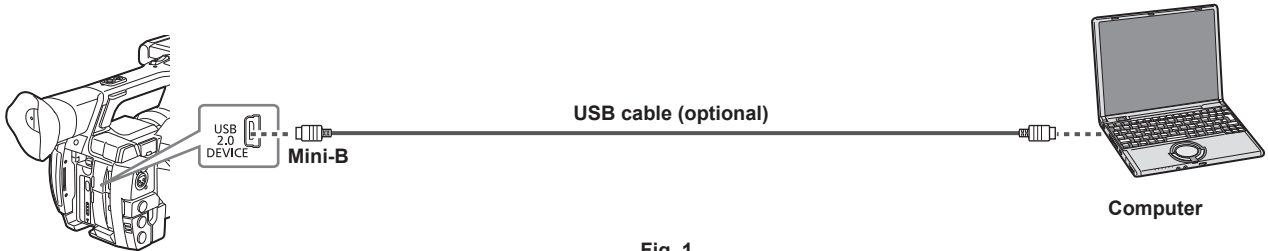

Fig. 1

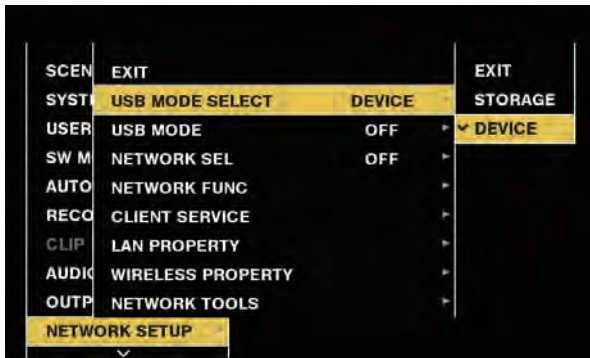

Fig. 2

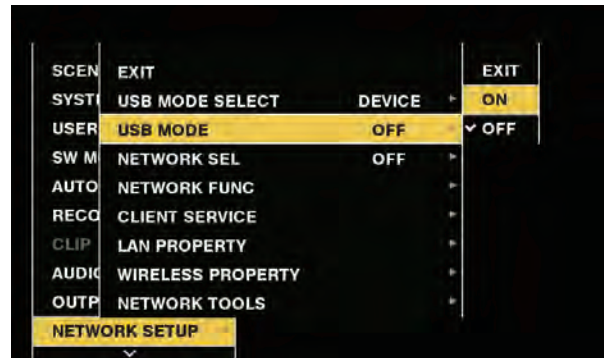

Fig. 3

**1** Connect the USB cable to the <USB2.0 DEVICE> terminal (device). (Fig. 1)

**2** Set to [DEVICE] in the main menu → [NETWORK SETUP] → [USB MODE SELECT]. (Fig. 2)

For details, refer to “Setting menu basic operations” (page 124).

**3** Set [ON] in the main menu → [NETWORK SETUP] → [USB MODE]. (Fig. 3)

During USB connection, [USB DEVICE CONNECTED] is displayed in the center of the viewfinder or LCD monitor. If it is not connected properly, [USB DEVICE DISCONNECTED] is displayed.

**4** Exit the USB device mode.

There are three methods:

- Turn the power switch of the camera to <OFF>.
- Press the <EXIT> button.

While in USB device mode, [Push EXIT to Return to CAMERA MODE] is displayed at the lower of the LCD monitor or viewfinder or screen.

- Press the USER button to which [USB MODE] has been assigned.

Returns to camera shooting status in approx. five seconds when the USB device mode ends.

#### NOTE

- The USB 2.0 cable is not supplied with the camera. Prepare a commercial USB 2.0 cable (double-shielded for noise suppression).
- A USB connection cable of up to 5 m is supported, however, a cable of 3 m or shorter is recommended as preferable.
- Before making USB connection for the first time, install P2 Viewer Plus software to your computer.
- Download the USB driver from the website and install it into your computer. For installation procedure of the driver, refer to the installation manual on the website.

For the latest information on the driver, visit the following website.

<http://pro-av.panasonic.net/>

- The camera supports only USB 2.0. Ensure your computer supports USB 2.0.
- When connecting the camera to a computer via USB, ensure that no other device is connected to the computer via USB.
- When connecting the camera via USB, do not eject the P2 card.
- When USB is connected, the P2 card access LED turns off when not accessed.
- When the camera is operating in the USB device mode, no camera shooting, recording/playback operation or clip thumbnail operation is allowed.
- When the camera is operating in the USB device mode, the P2 card remaining capacity and status are not displayed. Also, video/audio cannot be output or displayed.

### Connecting to external devices in USB host mode

You can save data on cards or other operations by connecting a storage device such as hard disk drive or solid-state drive that can be connected via USB 2.0 or USB 3.0 to the <USB3.0 HOST> terminal.



Switching to the USB host mode

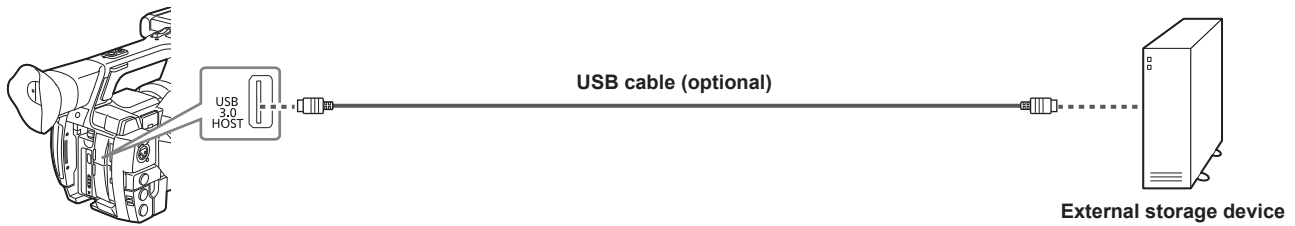

Fig. 1

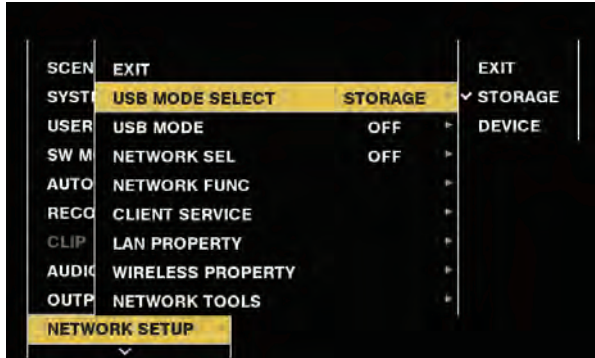

Fig. 2

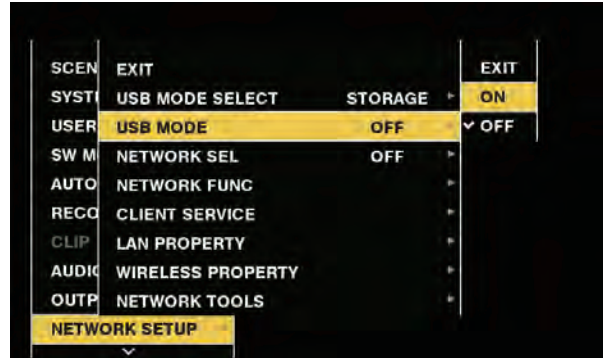

Fig. 3

**1** Connect the storage device to the <USB3.0 HOST> terminal. (Fig. 1)

- When connecting a storage device which supports USB 3.0, use a cable that conforms to the USB 3.0 standard.
- When a USB 2.0 cable is used, the transfer rates cannot be faster than the ability of USB 2.0.
- If the storage device is recognized and is usable, **USB** (gray) on the top right of the thumbnail screen changes to **USB** (white).

**2** Set to [STORAGE] in the main menu → [NETWORK SETUP] → [USB MODE SELECT]. (Fig. 2)

For details, refer to “Setting menu basic operations” (page 124).

**3** Set [ON] in the main menu → [NETWORK SETUP] → [USB MODE]. (Fig. 3)

- The camera is switched to the USB host mode.
- While in USB host mode, [USB STORAGE CONNECTED] is displayed in the center of the viewfinder or LCD monitor. If hard disk drive is not connected properly, [USB STORAGE DISCONNECTED] is displayed.

**4** Press the <THUMBNAIL> button.

- The thumbnail screen is displayed.
- Ensure that [USB] is displayed at the top right of the screen.
- If a storage device is connected, the icon that indicates storage device status at the top right illuminates. However, a red mark indicates that the device cannot be used.

For details on USB host mode, refer to “Connecting to external devices in USB host mode” (page 162).

**5** Exit the USB host mode.

There are two methods:

- Turn the power switch of the camera to <OFF>.
- With the thumbnail screen closed, set [OFF] in the main menu → [NETWORK SETUP] → [USB MODE].
- Press the USER button to which [USB MODE] has been assigned. Note that this is disabled when a menu or thumbnail is open.

**NOTE**

- In USB host mode, a P2 card can be played back. Camera image and external input cannot be recorded. Clips written to the hard disk drive cannot be played back on the camera.
- A storage device cannot be connected to the <USB2.0 HOST> terminal (page 19).
- While connecting a storage device, use the fully charged battery or connect an AC adaptor to the camera to avoid problems in copying or formatting operations.
- The <USB3.0 HOST> terminal also supports USB bus power (5 V, 0.9 A). However, there are certain devices that cannot run depending on the storage device used. In such cases, add a separate power supply to the storage device.
- Some storage devices may not function properly depending on the storage device and cable used.
- Do not connect multiple storage devices using a hub even if the storage devices are turned off. Do not connect other devices together with your storage device using a hub.
- During a format or copy operation, do not unplug the cable, eject the target P2 card, or turn off the camera or the storage device. Rebooting the camera and the storage device is required.
- A storage device with the SATA (Serial ATA) or PATA (Parallel ATA) interface connected using a USB conversion cable may not be recognized.
- Do not connect or disconnect the cable during playback on the camera. Playback may not be performed properly.

### Storage device types and available functions

The available functions differ depending on the storage device you will use. The storage device type is displayed after [PARTITION] on the left side of the storage device explorer screen.

For details, refer to “Storage device information display (explorer screen)” (page 166).

#### ■ Storage device type

Storage device type	Features
[TYPE S]	A special format to read/write data with high speed by card.
[P2STORE]	Indicates P2 STORE (AJ-PCS060G). Writing is disabled.
[FAT]	Storage devices where the primary partition is FAT16 or FAT32. The partition root or CONTENTS folder under any folders* is the target.
[OTHER]	Indicates other storage devices other than the above. File systems other than FAT16 and FAT32, such as NTFS.

\* The hierarchy of folders is down to the third level and the maximum number of folders is 100. Long file names and file names with double-byte characters are not supported. Examples of folder displays are shown below.

/CONTENTS	Can be displayed.
/SAMPLE/CONTENTS	Can be displayed.
/SAMPLE/20140101/CONTENTS	Can be displayed.
/SAMPLE/20140101/1200/CONTENTS	Cannot be displayed. (Cannot be displayed since this is a fourth level folder)

#### ■ Storage device types and available functions

Available functions	Storage device type			
	[TYPE S]	[P2STORE]	[FAT]	[OTHER]
Thumbnail display	✓	✓	✓	—
Card unit	Card*1 → Storage	✓	—	—
	Card*2 → Storage	—	—	—
Clip unit	Card → Storage	✓	—	—
Playback check*3	—	—	—	—
Clip image display	✓	✓	✓	—
Format	✓	—	✓	✓*4

\*1 P2 memory card, or microP2 memory card with 32 GB or lower

\*2 microP2 memory cards that exceed 32 GB

\*3 Playback from the storage device cannot be performed on the camera.

\*4 Storage devices with a capacity of 2 TB or more cannot be formatted.

#### NOTE

- Data cannot be copied or written back from the storage device to P2 card.
- Storage devices with capacities exceeding 2 TB (2048 GB) are not supported.
- Use a storage device within its guaranteed operational range (temperature, etc.).
- Do not place the storage device in a location that is unstable or subject to vibration.
- Use a storage device with sufficient capacity for copying.
- Because the storage device is very sensitive, reading, and writing data may become invalid depending on your usage. Please note that Panasonic has no responsibility for data loss caused from a storage device failure or other defects and any direct or indirect damage related to these.
- If the contents of the storage device used for copying data from the camera are replaced using another computer, the camera operations and storage device data cannot be guaranteed.
- For P2 cards containing defective clips, it is recommended that you copy data to a storage device after restoring in advance.

### Formatting a storage device

You can initialize the storage device to a usable format using the [TYPE S] or the [FAT] file system.



Fig. 1

- 1 Select [STORAGE] in the main menu → [CLIP] → [EXPLORE] and press the control stick.

This opens the explorer screen.

- 2 Select the desired format ([TYPE S], [FAT]) in the main menu → [CLIP] → [FORMAT(STORAGE)] and press the control stick. (Fig. 1)

- 3 Select [YES] in the confirmation message and press the control stick.

- 4 Select [YES] again when the confirmation message appears, and press the control stick.

This formats the storage device.

**NOTE**

• Formatting the storage devices erases all of its contents. Data cannot be recovered once it is formatted. Always check the data before formatting.

**Exporting to a storage device by card**

You can export to a storage device (write to a storage device from a P2 card) by P2 card. The copy results and the maximum number of items that can be copied vary depending on format type of the storage device. You cannot perform copying once the capacity of the storage device is exceeded.

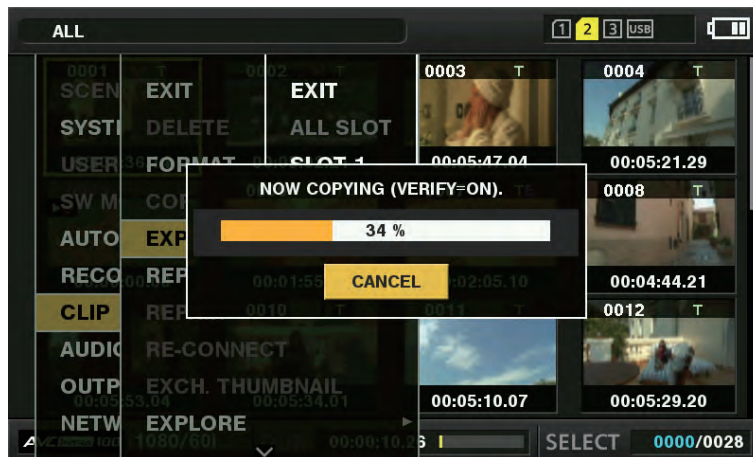

Fig. 1

■ [TYPE S]

A partition is created for each card, and all data included in the card are copied there. You can check the part numbers and serial numbers of the P2 cards that have been copied on the explorer screen of the camera.

The maximum number of items that can be copied is 23.

■ [FAT]

A folder is created for each card. All data included in the card are copied there. You can check the folder names in the explorer screen of the camera. Folders are created in two levels; the date folders on the first level and the time folders on the second.

Example) August 30, 2013, 12:34:56: /13-08-30/12-34-56

The maximum number of items that can be copied is 100.

- 1 Select [EXPORT] in the main menu → [CLIP] and press the control stick.

- 2 Move the cursor to the card slot number of the copy source and press the control stick.

For [TYPE S], selecting [ALL SLOT] exports all cards currently inserted.

**3 Select [YES] in the confirmation message and press the control stick.**

Exporting begins. A progress bar appears during exporting. (Fig. 1)  
 [COPY COMPLETED!] will be displayed when exporting is completed.

**NOTE**

- For export with [TYPE S], P2 card data and copied data can be verified (compared) automatically after exporting. Verification at the time of export is enabled in the factory setting. When you set to disable verification at the time of export, exported data is not verified, and the time until export completes will shorten. To disable verification, set [VERIFY] to [OFF] in the main menu → [CLIP] → [STORAGE COPY SETUP]. For [FAT], verification is not performed regardless of this setting.
- To discontinue the export process, press the control stick. A [CANCEL] confirmation message will appear. Select [YES] and press the control stick.
- Even if you cancel the process during verification, copying to the P2 card will continue until it is completed.
- microP2 memory cards that exceed 32 GB cannot be exported and imported. Use copied clips.

**Copying to a storage device by clip**

You can copy only the selected clips to a storage device.

**1 Go to the thumbnail screen. Use the control stick to place the cursor on a clip you want to copy and press the control stick.**

You can also select multiple clips.

**2 Select [STORAGE] in the main menu → [CLIP] → [COPY] and press the control stick.**

A list of folders or partitions in the storage device is displayed.

**3 Select the copy destination and press the control stick.**

**4 Select [YES] in the confirmation message and press the control stick.**

This starts the copying process. A progress bar is displayed during copying.  
 [COPY COMPLETED!] will be displayed when copying is completed.

**NOTE**

- When the storage device has a [FAT] file system, the folders displayed are as follows:
  - Root
  - Folders down to the third level including the CONTENTS folder
- To copy to a [TYPE S] storage device, one or more partitions are required. You can either format the storage device to [FAT] or perform copying after creating a partition through the export process.
- To cancel the copy process, use the control stick to place the cursor on [CANCEL] and press the control stick. A [CANCEL] confirmation message will appear. Select [YES] and press the control stick. Clips copied halfway to the copy destination are deleted.

**Storage device information display (explorer screen)**

You can perform the following operations in the explorer screen display.

- Storage device information display
- Storage device partition or folder thumbnail display and selection
- Target partition or folder selection

To display the explorer screen, select [STORAGE] in the main menu → [CLIP] → [EXPLORE] and press the control stick.

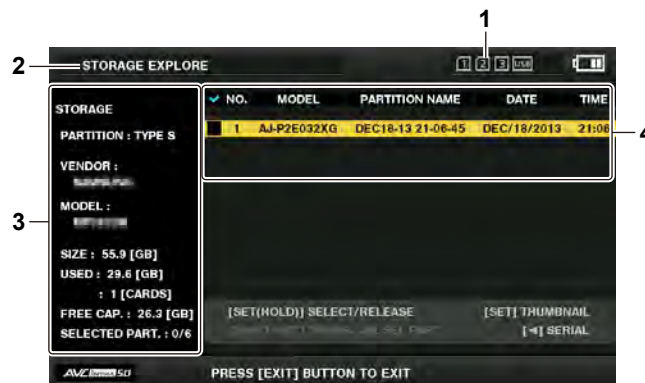

**1 Storage device indicator**

This displays the connected / not connected status and the storage device type.

**2 Display mode**

This indicates that the explorer screen of the storage device is currently displayed.

**3 Device information**

For [TYPE S] and [P2STORE] (storage devices that allow reading/writing by card)

[PARTITION]	[TYPE S]/[P2STORE]
[VENDOR]	Vendor name
[MODEL]	Model name
[SIZE]	Total capacity (unit: GB)
[USED]	Used capacity (unit: GB) Used P2 card area (unit: number of clips), maximum of 23
[FREE CAP.]	Remaining capacity (unit: GB)

[SELECTED PART.]	Number of partitions selected
------------------	-------------------------------

For [FAT] and [OTHER] (other storage devices)

[PARTITION]	[FAT]/[OTHER]
[VENDOR]	Vendor name
[MODEL]	Model name
[SIZE]	Total capacity (unit: GB)
[FREE CAP.]	Remaining capacity (unit: GB)
[SELECTED PART.]	Number of folders selected

**4 Partition or folder information**

For [TYPE S] and [P2STORE] (partition information)

<input checked="" type="checkbox"/>	Displays a checkmark when a target partition is selected
[NO.]	Partition number
[MODEL]	P2 card model name
[PARTITION NAME]	Name assigned to the partition
[DATE]	Partition record date
[TIME]	Partition record time
[SERIAL]	P2 card serial number

For [FAT] and [OTHER] (folder information)

<input checked="" type="checkbox"/>	Displays a checkmark when a target partition is selected
[NO.]	Folder number
[FOLDER NAME]	Folder name (excluding the CONTENTS folder)
[DATE]	Folder creation date
[TIME]	Folder creation time

**NOTE**

- For [TYPE S] storage devices, you can switch the display between the partition name and serial name using the control stick.
- If there is an invalid partition in [P2STORE], the partition information is displayed in gray.
- The remaining free space of the corresponding partition can be checked in the main menu → [CLIP] → [PROPERTY] → [FREE CAP. OF PARTITION].

**Selecting the target folder/partition in the explorer screen**

You can display all clips included in the selected partition/folder as thumbnails by selecting partitions/folders as targets. You can display up to six partitions/folders. When the seventh partition/folder is specified, setting is disabled and a warning is displayed.

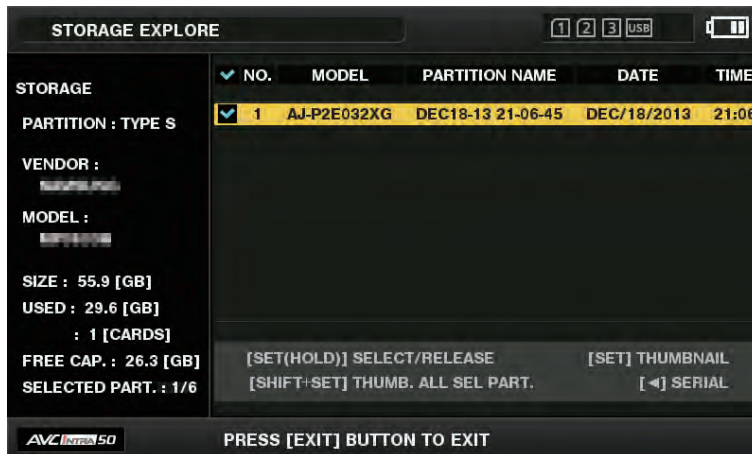

Fig. 1

**1** In the explorer screen, place the cursor on the partition/folder.

**2** Press and hold the control stick (for one second or more).

The partition/folder is selected and a checkmark is displayed. (Fig. 1)

The selected target partition/folder is valid until the storage device is disconnected or the power is turned off. To release the selected partition/folder, hold down the control stick (for one second or more) again on the selected partition.

Press the <CANCEL> button to deselect all partitions/folders.

**NOTE**

- In [TYPE S] storage devices, [MODEL] is [UNKNOWN] and clips recorded across other partitions will not be one normal clip. Copying clips to a [TYPE S] storage device changes the partition of the copy destination [MODEL] to [UNKNOWN].
- The partition name can be set when a [TYPE S] storage device is used. The partition name that has been set is displayed in [PARTITION NAME] on the explorer screen.



### Setting a partition name in the explorer screen

When the storage device is [TYPE S], the name (up to 20 characters) can be set to the partition. The preset partition name is displayed in [PARTITION NAME] on the explorer screen.

- 1 In the explorer screen, place the cursor on the partition you want to set up.**  
You can display the thumbnail list and set names for partitions by pressing the control stick.
- 2 Select [CHANGE PARTITION NAME] in the main menu → [CLIP] and press the control stick.**  
This displays the soft keyboard.
- 3 Enter the partition name and select [OK].**  
The partition name is set.

### Deleting the last partition in the explorer screen

You can delete the last partition on a [TYPE S] type storage device.

- 1 In the explorer screen, place the cursor on the last partition.**
- 2 Select [DELETE LAST PARTITION] in the main menu → [CLIP] and press the control stick.**

#### NOTE

- You can only delete the last partition when using a [TYPE S] storage device. You can only delete the last partition. You cannot delete other partitions.
- Since deleted partitions cannot be recovered, perform a check thoroughly before deleting.

### Displaying the storage device clip thumbnails and the video monitor

#### Displaying thumbnails

You can display and manage clips saved in a storage device, as well as display the thumbnail screen for clips saved in a P2 card attached to the camera.

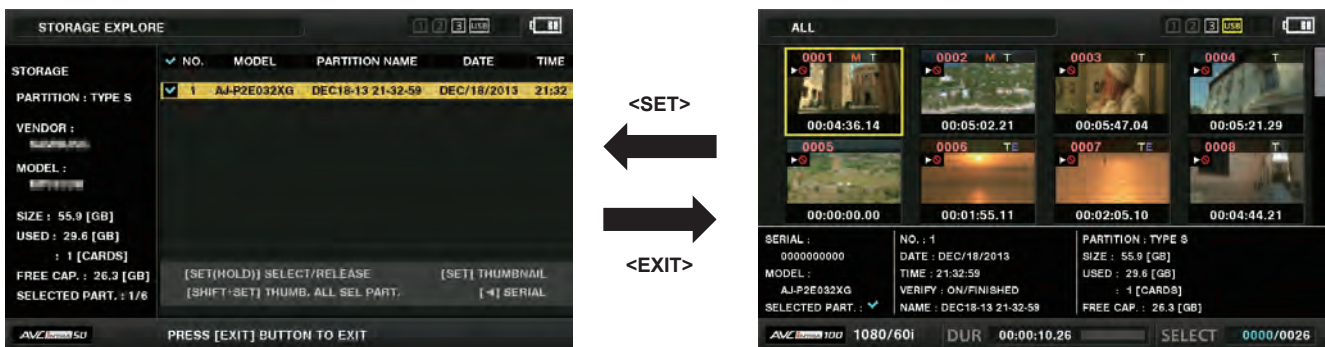

- 1 Open the explorer screen.**  
Partitions or folders are displayed in a list.
- 2 Use the control stick to place the cursor on the partition or folder you want to display on the thumbnail screen, and press the control stick.**  
This displays the thumbnails of clips in the partition or folder. You can go back to the main explorer screen by clicking the <EXIT> button.

#### NOTE

- When target partitions are selected, you can display thumbnails in all partitions selected as targets by pressing the control stick while holding down the <SHIFT> button.

#### Information display items



- 1 Storage device information**  
For [TYPE S]

[SERIAL]	P2 card serial number
[MODEL]	P2 card model name
[SELECTED PART.]	Displays a checkmark when a target partition is selected
[SELECTED PART. NO.]	List of selected partition numbers (only displayed when multiple partitions are selected)
[NO.]	Partition number
[DATE]	Partition record date
[TIME]	Partition record time
[VERIFY]	Verification settings and results during recording, [ON/FAILED] <ul style="list-style-type: none"> <li>• [ON/FAILED]: Verification performed. Items match.</li> <li>• [ON/FINISHED]: Verification performed but no match found. (For [P2STORE], [—] is displayed.)</li> <li>• [OFF]: Verification not performed</li> </ul>
[NAME]	Partition name defined by the user
[SIZE]	Total capacity of the storage device
[USED]	Used storage device capacity
[FREE CAP.]	Remaining storage device capacity

For [FAT]

[SELECTED PART.]	Displays a checkmark when a target partition is selected
[SELECTED PART. NO.]	List of selected folder numbers (only displayed when multiple folders are selected)
[NO.]	Folder number
[DATE]	Folder creation date
[TIME]	Folder creation time
[FOLDER]	Folder name (creation date and time are not displayed in the root folder)
[SIZE]	Total capacity of the storage device
[FREE CAP.]	Remaining storage device capacity

 **NOTE**

- You can change the thumbnail screen display if necessary.
- The 1001st clips onwards are not displayed.

**Displaying clip information**

You can display metadata of clips saved in a storage device. The procedure to display is the same as that of the P2 card clip properties.

- 1** In the storage device thumbnail screen, move the cursor to the target clip.
- 2** Select [CLIP PROPERTY] in the main menu → [CLIP] → [PROPERTY] and press the control stick.

This cannot be modified.

**Deleting clips**

You can delete unnecessary clips saved in a storage device.

- 1** In the storage device thumbnail screen, select the clip you want to delete.
- 2** Select [DELETE] in the main menu → [CLIP] and press the control stick.
- 3** Move the cursor to [YES] in the confirmation message and press the control stick.

 **NOTE**

- You may not be able to delete clips with defective clip or unknown clip indicators.

## Connecting to the remote operation panel (AK-HRP200G)

- You can remotely control some functions by connecting the remote operation panel AK-HRP200G (optional) via an IP connection.
- When you connect AK-HRP200G using a LAN cable and perform network settings of the camera and the AK-HRP200G, the camera automatically enters the remote control mode. For the connection settings, refer to “Setting for connection with Remote Operation Panel (AK-HRP200G)” (page 183).
- Turn the <AUTO/MANUAL> switch of the camera to <MANUAL>. Some items may not work in <AUTO> depending on the camera’s automatic adjustment settings. In addition, when you perform zoom operations in AK-HRP200G, set the camera’s <ZOOM> switch in the <SERVO> position.
- You can exit the remote control mode by disconnecting from the network from the AK-HRP200G, or removing the network cable and switching the camera’s power switch from <OFF> to <ON>.

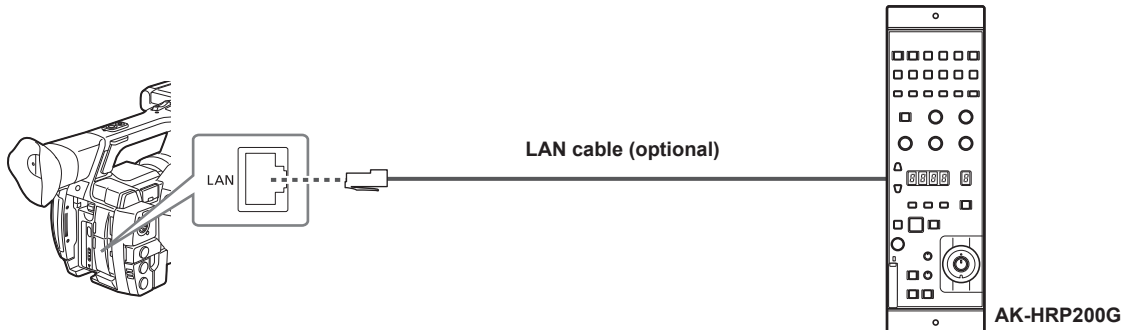

### Switch function in remote control mode

The following switches and buttons on the camera do not function in remote control mode.

- <MENU> button
- <SEL/PUSH SET> dial button
- <GAIN> switch
- <WHITE BAL> switch (works when set in the <A> position)
- <BARS> button
- Manual focus operation using the focus ring
- Switching between auto focus mode and manual focus mode using the <FOCUS> switch
- Motorized zoom operation of the zoom lever (grip side/handle side)

### Recording and playback operations in remote control mode

Recording and playback operations cannot be performed from remote operation panel AK-HRP200G. You can only perform these operations from the camera.

### Remote control unit connected to the camera

When AK-HRP200G is connected to the camera, the AK-HRP200G button's operations are as follows:

#### ■ Skin tone detail button (<SKINDTL>)

Operation varies depending on the lighting status of the button.

- When the button lights up, the operation follows the menu setting value of the camera (setting for skin tone detail).
- When the button lights off, the skin tone detail function is set to [OFF], regardless of the menu setting value of the camera.

After restarting the camera, the menu setting value is reflected in AK-HRP200G.

#### ■ Knee OFF button (<KNEE OFF>)

Operation varies depending on the lighting status of the button.

- When the button lights up, the knee function is set to [OFF], regardless of the menu setting value of the camera.
- When the button lights off, the operation follows the menu setting value of the camera (setting for the knee function).

After restarting the camera, the menu setting value is reflected in AK-HRP200G.

#### ■ Matrix button (<MATRIX>)

When the button lights up, the menu setting value of the camera is always applied (setting for matrix). The function cannot be turned [OFF] even if the button is pressed.

After restarting the camera, the menu setting value is reflected in AK-HRP200G.

#### ■ Scene file selection buttons (<SCENE1> - <SCENE4>)

Not supported.

#### ■ User file selection buttons (<USER1> - <USER3>)

You can select the camera's scene file F1 to F3. F4 to F6 cannot be selected.

#### ■ R flare/pedestal volume (<FLARE/PED R>), B flare/pedestal volume (<FLARE/PED B>)

Flare adjustment is not supported. Works only with the pedestal.

#### ■ Adjusted value display area (4 digits)

Display of CC filter, zoom, and focus values are not supported.



■ **Character/menu button (<CHARA/MENU>)**

The status and menu are displayed in the output image from the <SDI OUT>, <HDMI OUT>, and <GENLOCK IN/VIDEO OUT> terminals regardless of camera's menu setting value.

■ **Sense volume (<SENSE>)**

Zoom/focus speed can be adjusted.

- Turning it to the right accelerates the zoom/focus speed.
- Turning it to the left decelerates the zoom/focus speed.

■ **ND filter/CC filter display selection button <ND/CC>**

- Zoom mode and focus mode can be switched.

Press the display selection button, and select either zoom mode or focus mode.

- During zoom mode, the adjusted value display area (4 digits) shows [Zo].
- During focus mode, the adjusted value display area (4 digits) shows [Fo].

While the selection is displayed, you can change the adjusted value using the data set button (up) <UP>/data set button (down) <DOWN>.

- Auto focus and manual focus can be switched.

Press the display selection button, and select the adjusted value display area (4 digits) [AF.\*\*]. While the selection is displayed, select auto focus or manual focus by pressing the data set button (up) <UP> or data set button (down) <DOWN>.

- During manual focus, [AF.of] is displayed.
- During auto focus, [AF.on] is displayed.

- During frame rate mode, the adjusted value display area (4 digits) shows [Frof], but it does not operate on the camera.

■ **Data set button (up) <UP>**

Zooms in during zoom mode.

You can adjust focus (on the back) during focus mode.

■ **Data set button (down) <DOWN>**

Zooms out during zoom mode.

You can adjust focus (on the front) during focus mode.

■ **Selection dial <SELECT>**

You can adjust focus during zoom mode. Turning the dial to the right focuses on the back. Turning the dial to the left focuses on the front.

You can adjust zoom during focus mode. Turning the dial to the right performs zoom in, and turning the dial to the left performs zoom out.

 **NOTE**

- To perform the manual iris operation on the camera or remotely control the iris using the <CAM REMOTE> terminal during IP connection, enable the operation by pressing the <IRIS> button on the camera. When the manual iris operation is enabled on the camera, the screen's iris is displayed in black and white inversion. You cannot perform zoom operations using the <CAM REMOTE> terminal.
- You can use a straight-through or a crossover LAN cable to directly connect AK-HRP200G to the camera.
- When the camera is restarted with the camera and AK-HRP200G connected via IP, the camera power button of AK-HRP200G (<HEAD POWER>) might blink in red then light up in green.
- To use the camera as a standalone device, you need to release the remote control mode by pressing the camera power button <HEAD POWER> of AK-HRP200G.
- The operation of connecting via IP and remote controlling the camera from multiple devices such as the AK-HRP200G cannot be guaranteed.
- Use the camera by matching the synchro scan display settings ([sec] or [deg]) of AK-HRP200G and the camera. Even if the camera's synchro scan display settings are changed, it will not sync with the AK-HRP200G display.
- When the camera is connected to AK-HRP200G via IP, the P2 playlist editing function is not available.

## Connecting to P2 ROP application

Using a P2 ROP application that operates on an iPad connected to the camera via wireless LAN, you can remotely control some functions of the camera.

For the settings for network connection, refer to “Setting for connection with P2 ROP application” (page 182).

For details on operation of P2 ROP application, refer to the help file.

### Switch functionality in remote control mode

The following switches and buttons on the camera do not function in remote control mode.

- <MENU> button
- <SEL/PUSH SET> dial button
- <GAIN> switch
- <WHITE BAL> switch
- <BARS> button
- Manual focus operation using the focus ring
- Switching between auto focus mode and manual focus mode using the <FOCUS> switch
- Motorized zoom operation of the zoom lever (grip side/handle side)

### Recording and playback operations in remote control mode

When connected to the P2 ROP application, recording and playback can be performed with either the camera or the P2 ROP application.

#### NOTE

- The status adjusted by connecting the P2 ROP application will always be recorded on the camera.
- When the camera is connected to the P2 ROP application, the P2 playlist editing function is not available.
- To enable operations on the camera, disconnect the network on the iPad side, and then turn the power switch of the camera from <OFF> to <ON>.

## Chapter 9 **Network Connection**

---

This chapter describes how to use the camera by connecting to network.

## Network connection

The camera can be connected to the network via wireless LAN, wired LAN, or 4G/LTE.

For details on wireless modules that can be connected, visit the support desk at the following website:

<http://pro-av.panasonic.net/>

To use wireless LAN, attach AJ-WM30 (optional) to the <USB2.0 HOST> terminal.

To use wired LAN, connect a LAN cable to the <LAN> terminal on the rear side.

To use 4G/LTE, connect a USB modem that is compliant with the <USB2.0 HOST> terminal.

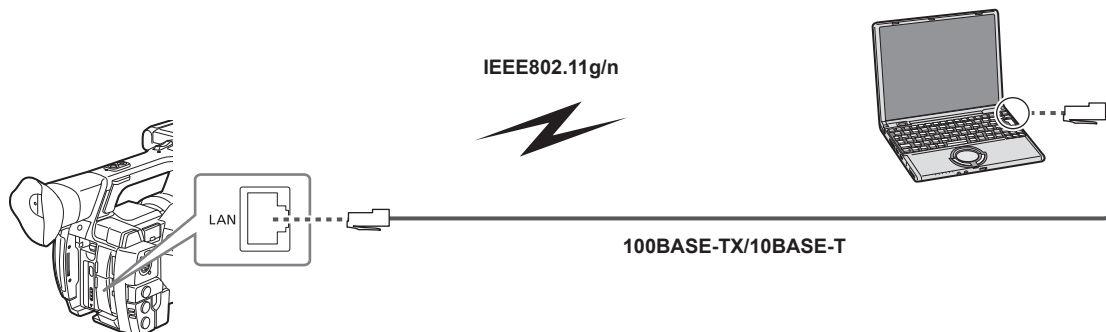

### Available functions

When the camera is connected to network, the following functions are available.

- Checking camera status
- Checking thumbnail images
- Proxy playback
- Downloading proxy file/clip management information
- Displaying/editing metadata
- Adding/deleting metadata (shot mark/text memo)
- Camera remote control (collective operations of recording control and time code/user bits)
- Remote controlling the camera from the Remote Operation Panel (AK-HRP200G) (wired LAN only)
- Connecting to P2 ROP application
- Streaming function

#### NOTE

- When 4G/LTE is used, only the function to send/receive clips from/to the camera (clip transfer via FTP client function) can be used.

### Operating environment

The following operating environment is required to connect to network.

- Windows
  - Microsoft Windows® 8.1 Professional 32/64 bit, Internet Explorer 11 (classic view)
- Macintosh
  - Mac OS X v10.9.x (Mavericks)\*, Safari 7
  - \* Operation is guaranteed only when preinstalled or clean installed.
- iPad/iPhone
  - iOS v7.x

### Web browser

A Web browser is required to perform web control.

- For the latest information on the supported browsers, visit the following website:
  - <http://pro-av.panasonic.net/>

### Media player

QuickTime is required for proxy video playback.

To display streaming video on P2 Browser, VLC Media Player is required.

- For the latest information on the versions that are operation tested, visit the following website:
  - <http://pro-av.panasonic.net/>

### Java run time

On computers, Java run time is used for the camera status display. Java is required to display the panel.

- For the latest information on the versions that are operation tested, visit the following website:
  - <http://pro-av.panasonic.net/>

## Preparing for connection

### For wireless LAN

Connect the wireless module AJ-WM30 (optional) to the camera. The grip belt can be removed.

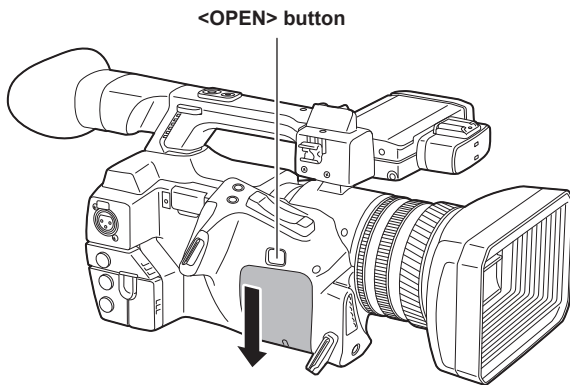

Fig. 1

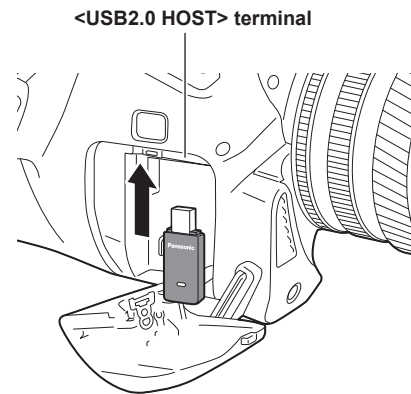

Fig. 2

**1** Press the <OPEN> button and remove the cover by sliding it in the direction of the arrow. (Fig. 1)

**2** Connect the wireless module to the <USB2.0 HOST> terminal. (Fig. 2)

Insert it all the way.

**3** Slide the removed cover to close it.

#### NOTE

- When removing the wireless module, pull it down straight.

### Storing the wireless module

The removed wireless module can be stored in the grip belt.

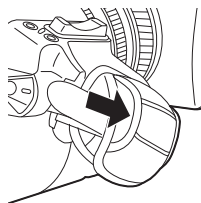

### Cautions when using wireless module

Read the operating manual of the wireless module thoroughly and understand it before using.

To prevent accidental operation, there are restrictions as follows:

- Supported standard: IEEE802.11g/n  
IEEE802.11a and IEEE802.11b cannot be used.
- Communication frequency: 2412 MHz to 2462 MHz (1ch, 6ch, 11ch)  
12ch and higher cannot be used.

#### ■ For use overseas

The following four types of products are available to comply with laws regarding radio wave of every region in the world. The products can be used only in the country or region where they are supported.

- AJ-WM30MC  
People's Republic of China
- AJ-WM30P  
United States of America, Canada, Mexico, Argentina, Peru, Taiwan
- AJ-WM30E  
EU member nations, EFTA member nations, Australia, New Zealand, Russia, Ukraine, Saudi Arabia, UAE, Kuwait, Oman, Egypt, Republic of South Africa, Korea, Philippines, Malaysia, Singapore
- AJ-WM30  
Japan

#### NOTE

- In France, using outdoors is prohibited.

## For wired LAN

Connect a LAN cable.

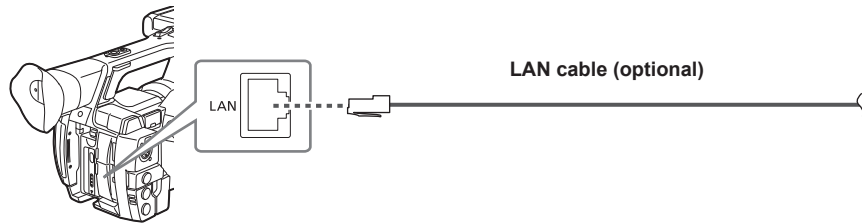

- 1 Connect the LAN cable to the <LAN> terminal on the rear side.

## For 4G/LTE

Attach the 4G/LTE USB modem (optional) to the camera. The grip belt can be removed.

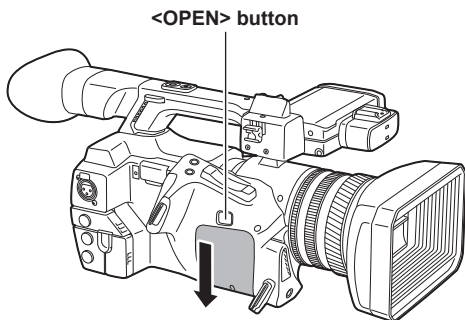

Fig. 1

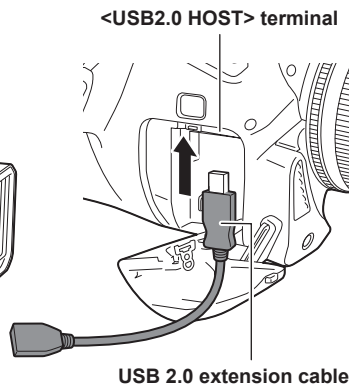

Fig. 2

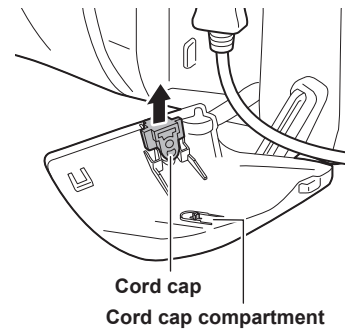

Fig. 3

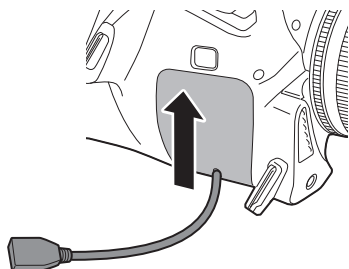

Fig. 4

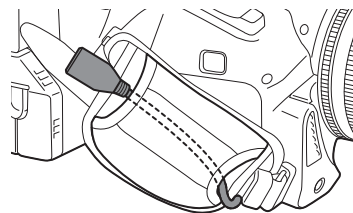

Fig. 5

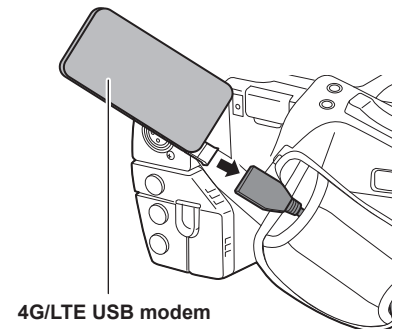

Fig. 6

- 1 Press the <OPEN> button and remove the cover by sliding it in the direction of the arrow. (Fig. 1)
- 2 Connect the USB 2.0 extension cable (optional: type A male/female, 0.2 m) to the <USB2.0 HOST> terminal. (Fig. 2)
- 3 Remove the cord cap inside the removed cover (Fig. 3), pass the USB 2.0 extension cable there, and slide the cover to close. (Fig. 4)  
The removed cord cap can be stored in the cord cap compartment inside the cover.
- 4 Pass the USB 2.0 extension cable through the grip belt compartment. (Fig. 5)
- 5 Connect the 4G/LTE USB modem. (Fig. 6)  
The 4G/LTE USB modem can be stored in the grip belt.

### NOTE

- For details on 4G/LTE USB modem that can be connected, visit the support desk at the following website:  
[http://pro-av.panasonic.net/en/sales\\_o/p2/server/4glte.html](http://pro-av.panasonic.net/en/sales_o/p2/server/4glte.html)

## Network settings

To use wireless LAN or wired LAN, configuration of each setting is required. Configure the settings according to the function to use. When the main menu → [NETWORK SETUP] → [USB MODE SELECT] is set to [STORAGE], the network function cannot be used.

### Wireless LAN settings

This section describes the settings to connect the camera to mobile devices (iPad/iPhone), computers, or wireless access point via wireless LAN.

#### [DIRECT] mode

Use the following procedures when accessing to the network function of the camera directly from a smartphone, tablet, or computer.

**1** Select [DIRECT] in the main menu → [NETWORK SETUP] → [WIRELESS PROPERTY] → [TYPE].

**2** Set each item in the main menu → [NETWORK SETUP] → [WIRELESS PROPERTY] as necessary.

[MAC ADDRESS]: MAC address of wireless LAN (cannot be changed)

[SSID]: Network name of the camera (SSID) (Factory setting: [AJ-PX270])

[CHANNEL]: Channel to use (Factory setting: [AUTO])

[ENCRYPTION]: Encryption format to be used (Factory setting: [WPA2-AES])

[ENCRYPT KEY]: WPA2 encryption key (Factory setting: [01234567890123456789abcdef])

[DHCP]: Setting whether to use automatic acquisition via DHCP ([ENABLE]: Use automatic acquisition/[DISABLE]: Does not use automatic acquisition) (Factory setting: [ENABLE]) (cannot be set)

[IP ADDRESS]: IP address of the camera (Factory setting: [192.168.0.1]).

[SUBNET MASK]: Subnet mask (Factory setting: [255.255.255.0])

[DEFAULT GATEWAY]: Default gateway (Factory setting: [192.168.0.254]) (cannot be set)

[PRIMARY DNS]: Primary DNS server setting (Factory setting: [0.0.0.0]) (cannot be set)

[SECONDARY DNS]: Secondary DNS server setting (Factory setting: [0.0.0.0]) (cannot be set)

[DHCP SERVER]: Setting whether to use DHCP SERVER function ([ENABLE]: Use DHCP SERVER function/[DISABLE]: Does not use DHCP SERVER function) (Factory setting: [ENABLE])

**3** Select [WLAN] in the main menu → [NETWORK SETUP] → [NETWORK SEL].

If the setting is changed, the camera will restart as necessary.

**4** Select SSID from the list of the access points for mobile devices or computers and enter the password (encryption key).

Display the access point list screen in wireless setting and select [SSID] of the camera.

- Factory setting: [AJ-PX270]

When the password confirmation screen appears, enter the password (encryption key).

- Factory setting: [01234567890123456789abcdef]

**5** Check the network connection.

When the setting is completed, confirm that network connection of mobile devices (iPad/iPhone) and computers is made properly.

Application (P2 Browser) which requires network can be used when network connect is made properly. However, if connected with [DIRECT], the FTP client function cannot be used.

#### [INFRA] mode (when SSID is manually entered)

Use the following procedures when manually connecting to a wireless access point.

**1** Select [INFRA] in the main menu → [NETWORK SETUP] → [WIRELESS PROPERTY] → [TYPE].

**2** Set each item in the main menu → [NETWORK SETUP] → [WIRELESS PROPERTY] as necessary.

[MAC ADDRESS]: MAC address of wireless LAN (cannot be changed)

[CHANNEL]: Channel to be used (Factory setting: [AUTO]) (cannot be set)

[DHCP]: Setting whether to use automatic acquisition via DHCP ([ENABLE]: Use automatic acquisition/[DISABLE]: Does not use automatic acquisition) (Factory setting: [ENABLE])

[IP ADDRESS]: IP address of the camera (Factory setting: [192.168.0.1]).

[SUBNET MASK]: Subnet mask (Factory setting: [255.255.255.0])

[DEFAULT GATEWAY]: Default gateway (Factory setting: [192.168.0.254])

[PRIMARY DNS]: Primary DNS server setting (Factory setting: [0.0.0.0]) (When [DHCP] is set to [ENABLE] and can be acquired from the DNS server, the DNS server value which is acquired externally is overwritten. When the value is [0.0.0.0], the server is not set.)

[SECONDARY DNS]: Secondary DNS server setting (Factory setting: [0.0.0.0]) (When [DHCP] is set to [ENABLE] and can be acquired from the DNS server, the DNS server value which is acquired externally is overwritten. When the value is [0.0.0.0], the server is not set.)

[DHCP SERVER]: Setting whether to use the DHCP SERVER function ([ENABLE]: Use the DHCP SERVER function/[DISABLE]: Does not use the DHCP SERVER function) (Factory setting: [ENABLE]) (cannot be set)

**3** Select [WLAN] in the main menu → [NETWORK SETUP] → [NETWORK SEL].

If the setting is changed, the camera will restart as necessary.

**4** Enter information on the wireless access point to connect to.

Select [MANUAL] in the main menu → [NETWORK SETUP] → [WIRELESS PROPERTY] → [SSID INPUT MODE].

Enter SSID of the wireless access point for destination in [SSID] of the camera.

Select the encryption method to be used from the camera's [ENCRYPTION].

- Factory setting: [WPA2-AES]

Enter a password of the wireless access point for destination in [ENCRYPT KEY] of the of the camera.

## 5 Check the network connection.

When the setting is completed, confirm that network connection between the camera and the wireless access point is made properly.

When network connection is made properly, the network status icon at the upper right of the thumbnail screen changes in yellow, and applications (P2 Browser, FTP client function) which require network can be used.

### NOTE

- There are following restrictions while wireless LAN is set.
  - Regardless of menu settings, signals are not output from the <GENLOCK IN/VIDEO OUT> terminal.
  - The LCD monitor and viewfinder cannot be used together. If you close the LCD monitor, the viewfinder can be used.
- The startup time after turning on the power may be longer due to starting of the network.
- When you change the settings of [NETWORK SEL], the changes will not be reflected until the camera is restarted. After the settings have been changed, the setting screen termination may take time due to the restart of the network service.
- All of the IP address, subnet mask, and default gateway must be correctly set.  
If the warning [CANNOT ACCESS GATEWAY!] appears at the termination of the setting screen, contact the administrator of the network in use.
- If you do not use the default gateway and DNS, set them to [0.0.0.0].
- DHCP and DNS may not function properly depending on the network environment.

### [INFRA] mode (when SSID is selected from the list)

Use the following procedures when the wireless access point to connect to is selected from a list.

#### 1 Select [INFRA] in main menu → [NETWORK SETUP] → [WIRELESS PROPERTY] → [TYPE].

#### 2 Set each item in main menu → [NETWORK SETUP] → [WIRELESS PROPERTY] as necessary.

[MAC ADDRESS]: MAC address of wireless LAN (cannot be changed)

[CHANNEL]: Channel to be used (Factory setting: [AUTO]) (cannot be set)

[DHCP]: Setting whether to use automatic acquisition via DHCP ([ENABLE]: Automatic acquisition is used/[DISABLE]: Automatic acquisition is not used) (Factory setting: [ENABLE])

[IP ADDRESS]: IP address of the camera (Factory setting: [192.168.0.1]).

[SUBNET MASK]: Subnet mask (Factory setting: [255.255.255.0])

[DEFAULT GATEWAY]: Default gateway (Factory setting: [192.168.0.254])

[PRIMARY DNS]: Primary DNS server setting (Factory setting: [0.0.0.0]) (When [DHCP] is set to [ENABLE] and can be acquired from the DNS server, the DNS server value which is acquired externally is overwritten. When the value is [0.0.0.0], the server is not set.)

[SECONDARY DNS]: Secondary DNS server setting (Factory setting: [0.0.0.0]) (When [DHCP] is set to [ENABLE] and can be acquired from the DNS server, the DNS server value which is acquired externally is overwritten. When the value is [0.0.0.0], the server is not set.)

[DHCP SERVER]: Setting whether to use the DHCP SERVER function ([ENABLE]: Use the DHCP SERVER function/[DISABLE]: Does not use the DHCP SERVER function) (Factory setting: [ENABLE]) (cannot be set)

#### 3 Select [WLAN] in main menu → [NETWORK SETUP] → [NETWORK SEL].

If the setting is changed, the camera will restart as necessary.

#### 4 Enter information on the wireless access point to connect to.

1) Select [SELECT] in the main menu → [NETWORK SETUP] → [WIRELESS PROPERTY] → [SSID INPUT MODE].

When [SSID] is selected and the <SET> button is pressed, the SSID connection destination list screen (page 179) is displayed.

2) Select the SSID of the connection destination wireless access point using the control stick, and then press the <SET> button.

- You can delete the selected SSID from the connection history by selecting SSID and pressing the <SET> button while the <SHIFT> is pressed.
- You can clear all the SSID connection history by pressing the <EXIT> button while pressing the <SHIFT> button.

3) Enter the password of the wireless access point to connect to the camera's [ENCRYPT KEY].

## 5 Check the network connection.

When the setting is completed, confirm that network connection between the camera and the wireless access point is made properly.

When network connection is made properly, the network status icon at the upper right of the thumbnail screen changes in yellow, and applications (P2 Browser, FTP client function) which require a network connection can be used.

### NOTE

- There are following restrictions while wireless LAN is set.
  - Regardless of menu settings, signals are not output from the <GENLOCK IN/VIDEO OUT> terminal.
  - The LCD monitor and viewfinder cannot be used together. If you close the LCD monitor, the viewfinder can be used.
- The startup time after turning on the power may be longer due to starting of the network.
- When you change the settings of [NETWORK SEL], the changes will not be reflected until the camera is restarted. After the settings have been changed, the setting screen termination may take time due to the restart of the network service.
- All of the IP address, subnet mask, and default gateway must be correctly set.  
If the warning [CANNOT ACCESS GATEWAY!] appears at the termination of the setting screen, contact the administrator of the network in use.
- If you do not use the default gateway and DNS, set them to [0.0.0.0].
- DHCP and DNS may not function properly depending on the network environment.
- A maximum of 20 connections are saved in the connection history. When this number is exceeded, the oldest entries are deleted.
- The status of SSID connection destination list is current at the time the list was displayed and is not automatically refreshed.



## ■ SSID connection destination list screen

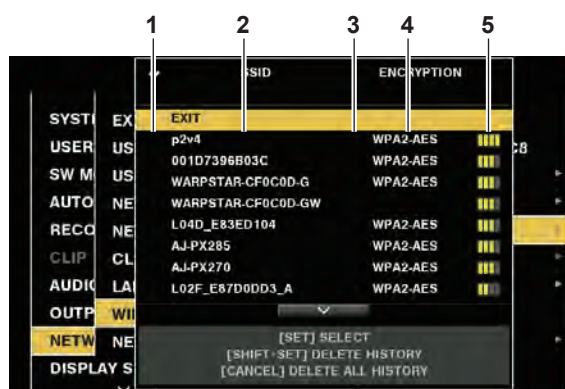

### 1 Selection status

A checkmark [✓] is displayed on the currently selected SSID. (This does not show the connection status).

### 2 SSID

The list of the detected SSID and SSID registered in the connection history are displayed. SSIDs are displayed in order from the one with the strongest signal.

### 3 Past connection history

[H] is displayed in the SSID that has a past connection history. SSID with past connection histories are displayed even if the camera is outside the service area.

### 4 Encryption format

This is the encryption method used by the access point.

### 5 Radio wave strength

This shows the signal strength of the access point.

## [4G/LTE] mode

Use the following procedure when you connect the camera with the 4G/LTE USB modem.

### 1 Select [4G/LTE] in the main menu → [NETWORK SETUP] → [NETWORK SEL].

### 2 Check the network connection.

Check whether to connect the camera to the network with 4G/LTE.

When network connection is made properly, the network status icon at the upper right of the thumbnail screen changes in yellow, and applications (FTP client function) which require network can be used.

## NOTE

- There are following restrictions while [4G/LTE] is set.
  - Regardless of menu settings, signals are not output from all external video output terminals.
  - The LCD monitor and viewfinder cannot be used together. If you close the LCD monitor, the viewfinder can be used.
  - microP2 memory cards can be used only in slot 1. (They cannot be in slot 2.)
- The startup time after turning on the power may be longer due to starting of the network.
- When you change the settings of [NETWORK SEL], the changes will not be reflected until the camera is restarted. After the settings have been changed, the setting screen termination may take time due to the restart of the network service.

## Wired LAN settings

The settings to connect to computers using the wired LAN are as follows.

### 1 Set each item in the main menu → [NETWORK SETUP] → [LAN PROPERTY] as necessary.

[DHCP] and [DHCP SERVER] are mutually exclusive.

**[MAC ADDRESS]:** MAC address of wired LAN (cannot be changed)

**[DHCP]:** Setting whether to use automatic acquisition via DHCP (**[ENABLE]:** Use automatic acquisition/**[DISABLE]:** Does not use automatic acquisition (Factory setting: [ENABLE])

**[IP ADDRESS]:** IP address (Factory setting: [192.168.0.1])

**[SUBNET MASK]:** Subnet mask (Factory setting: [255.255.255.0])

**[DEFAULT GATEWAY]:** Default gateway (Factory setting: [192.168.0.254])

**[PRIMARY DNS]:** Primary DNS server setting (Factory setting: [0.0.0.0])

**[SECONDARY DNS]:** Secondary DNS server setting (Factory setting: [0.0.0.0])

**[DHCP SERVER]:** Setting whether to use the DHCP SERVER function (**[ENABLE]:** Uses the DHCP SERVER function/**[DISABLE]:** Does not use the DHCP SERVER function) (Factory setting: [DISABLE])

### 2 Select [LAN] in the main menu → [NETWORK SETUP] → [NETWORK SEL].

### 3 Configure the settings of wired LAN of your computer.

(For Windows)

Display [Properties] in [Internet Protocol Version 4 (TCP/IPv4)] and configure the settings. For details on how to display the screen, refer to [Start] → [Help and Support].

- When [DHCP SERVER] is set to [ENABLE] on the camera  
Select [Obtain an IP address automatically] and [Obtain DNS server address automatically] in the [General] tab. Select [Automatic private IP address] in the [Alternate Configuration] tab.
  - When [DHCP SERVER] is set to [DISABLE] on the camera  
Select [Use the following IP address] in the [General] tab.
    - [IP address]: Enter the same address as that of the camera.
    - [Subnet mask]: Enter the same value as that of the camera.
    - [Default gateway]: Enter the same address as that of the camera.
    - [Preferred DNS server]/[Alternate DNS server]: Not necessarily to be entered.
- (For Mac OS)
- When [DHCP SERVER] is set to [ENABLE] on the camera  
[Configure IPv4]: Select [Using DHCP].  
[Configure IPv6]: Select [Automatically].
  - When [DHCP SERVER] is set to [DISABLE] on the camera  
[Configure IPv4]: Select [Manually] and enter the following items.
    - [IP Address]
    - [Subnet Mask]
    - Entering [Router] is not required. Leave it blank.[Configure IPv6]: Select [Automatically].

### NOTE

---

- The startup time after turning on the power may be longer due to starting of the network.
- When you change the settings of [NETWORK SEL], the changes will not be reflected until the camera is restarted. After the settings have been changed, the setting screen termination may take time due to the restart of the network service.
- All of the IP address, subnet mask, and default gateway must be correctly set.  
If a warning [CANNOT ACCESS GATEWAY!] appears at the termination of the setting screen, contact the administrator of the network you use.
- If you do not use default gateway and DNS, set them to [0.0.0.0].
- DHCP and DNS may not function properly depending on the network environment.

## Network function

### P2 browser function settings and connection status check

#### Starting application (P2 Browser) from web browser

After completing the network connection with your mobile device or computer, start the browser of the mobile device or computer, and then start the application (P2 Browser).



Fig. 1

**1 Select [BROWSE] or [BROWSE (+CTRL)] in the main menu → [NETWORK SETUP] → [NETWORK FUNC] → [HTTP SERVER].**

P2 browser function is enabled.

**2 Start the browser of your mobile device or computer (Safari, Internet Explorer).**

**3 Enter the IP address set for the camera in the address entry field of the browser.**

When [DHCP] is set to [ENABLE] in [INFRA] mode, check the IP address of the camera from the main menu → [NETWORK SETUP] → [NETWORK TOOLS] → [STATUS DISPLAY].

- Factory setting: [192.168.0.1]

**4 If you use a computer, press the Enter key, and if you use iPad/iPhone, tap the GO button.**

The web application (P2 Browser) starts up.

**5 Enter [USER NAME] and [PASSWORD] on the entry screen.**

Enter [USER NAME] (Factory setting: [guest]) and [PASSWORD] (Factory setting: [p2guest]) of [USER ACCOUNT] that have been set for the camera.

When a screen like (Fig. 1) appears (for iPad), the connection has been established.

User account name and password can be set in the main menu → [NETWORK SETUP] → [NETWORK FUNC] → [USER ACCOUNT].

Accounts can be created or deleted, and the passwords can be changed in the main menu → [NETWORK SETUP] → [NETWORK FUNC] → [ACCOUNT LIST].

Enter up to 31 characters for a user account name, and characters between 6 and 15 for a password.

For information on P2 Browser, refer to the User Guide of "P2 Web Application" on the following website:

<http://pro-av.panasonic.net/en/manual/index.html>

#### NOTE

- When [NETWORK SEL] is [OFF] or set to [4G/LTE], the P2 browse function cannot be used.

### Network operation status display (mode check function)

Push the <DISP/MODE CHK> switch on the camera towards the <CHK> side twice to check the network operation status in the mode check [FUNCTION] screen.

For details, refer to "[FUNCTION] screen" (page 157).

### Setting the P2 playlist edit function

#### Starting application (P2 Playlist Editor) from web browser

After completing the network connection with your mobile device or computer, start the browser of the mobile device or computer, and then start the application (P2 Playlist Editor).

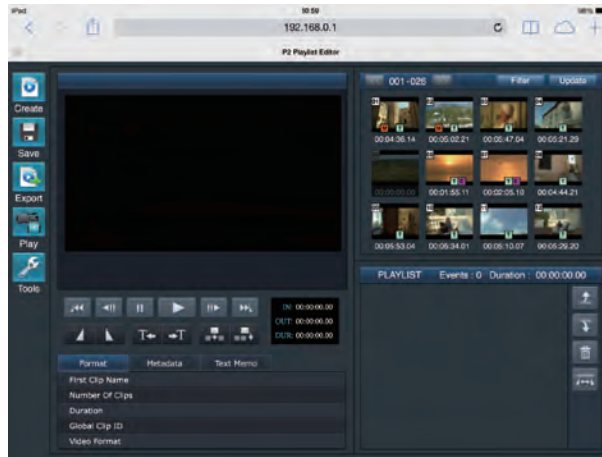

Fig. 1

**1** Select [ON] in the main menu → [NETWORK SETUP] → [NETWORK FUNC] → [PLAYLIST].

The mode changes to the playlist edit mode.

**2** Start the browser of your mobile device or computer (Safari, Internet Explorer).

**3** Enter the IP address set for the camera in the address entry field of the browser.

- Factory setting: [192.168.0.1]

**4** If you use a computer, press the Enter key, and if you use iPad/iPhone, tap the GO button.

The web application (P2 Playlist Editor) starts up.

**5** When the confirmation screen is displayed, enter [USER NAME] and [PASSWORD] on the entry screen.

Enter [USER ACCOUNT] (Factory setting: [guest]) and [PASSWORD] (Factory setting: [p2guest]) that have been set for the camera.

When a screen like (Fig. 1) appears, the connection has been established.

User account name and password can be set in the main menu → [NETWORK SETUP] → [NETWORK FUNC] → [USER ACCOUNT].

Accounts can be created or deleted, and the passwords can be changed in the main menu → [NETWORK SETUP] → [NETWORK FUNC] → [ACCOUNT LIST].

Enter up to 31 characters for the user account name, and 6 to 15 characters for the password.

For information on P2 Playlist Editor, refer to the User Guide of "P2 Web Application" on the following website:

<http://pro-av.panasonic.net/en/manual/index.html>

**NOTE**

- When [NETWORK SEL] is set to [OFF] or [4G/LTE], the P2 playlist editing function cannot be used.
- The number of clients that can be connected simultaneously during the playlist edit function is 1.

**Setting for connection with P2 ROP application**

Using the P2 ROP application on an iPad connected to the camera via wireless LAN, you can remotely control some functions.

To connect an iPad to the camera via wireless LAN, configure the settings in the following procedure.

**Network setting on the camera**

**1** Set wireless LAN.

Refer to steps 1 to 3 in "[DIRECT] mode" to configure the setting.

**2** Set the remote control function.

- 1) Set the main menu → [NETWORK SETUP] → [NETWORK FUNC] → [HTTP SERVER] to [BROWSE (+CTRL)].
- 2) Set the main menu → [NETWORK SETUP] → [NETWORK FUNC] → [IP REMOTE] to [ENABLE].

**3** Set each item in the main menu → [NETWORK SETUP] → [NETWORK FUNC] → [USER ACCOUNT].

[USER NAME]: Sets the user account name. (Factory setting: [guest])

[PASSWORD]: Sets the password. (Factory setting: [p2guest]) Enter up to 31 characters for the user account name, and 6 to 15 characters for the password.

**iPad setting**

Refer to the help file of P2 ROP application.

**NOTE**

- To connect an iPad to the camera via wireless LAN, the following information of the camera is required.
  - User account name
  - Password

- IP address (when the camera's main menu → [NETWORK SETUP] → [WIRELESS PROPERTY] → [DHCP SERVER] is set to [ENABLE], IP address does not need to be set)

## Setting for connection with Remote Operation Panel (AK-HRP200G)

You can remotely control some functions by connecting the remote operation panel AK-HRP200G (optional) via an IP connection.

To remotely control the camera after connecting the AK-HRP200G using a LAN cable, configure the settings using the following procedures:

### 1 Configure the network settings of the camera.

Set [DISABLE] in the main menu → [NETWORK SETUP] → [LAN PROPERTY] → [DHCP], and refer to steps 1 to 2 in "Wired LAN settings" (page 179) to configure the network settings.

### 2 Set the camera's main menu → [NETWORK SETUP] → [NETWORK FUNC] → [IP REMOTE] to [ENABLE].

### 3 Set each item in the camera's main menu → [NETWORK SETUP] → [NETWORK FUNC] → [USER ACCOUNT].

**[USER NAME]:** Sets the user account name. (Factory settings: [guest])

**[PASSWORD]:** Sets the password. (Factory setting: [p2guest])

Enter up to 31 characters for the user account name, and 6 to 15 characters for the password.

### 4 Configure the network settings of the AK-HRP200G.

For the network settings, use ROP setup software that is supplied with AK-HRP200G.

#### NOTE

- The following camera information is required to connect to the AK-HRP200G.
  - User account name
  - Password
  - IP address
  - Port number: 49152
- Use Ver4.01.00 or later versions of the AK-HRP200G firmware.
- For details on the operations of ROP setup software, refer to the Operating Instructions of the AK-HRP200G.
- Use Ver3.0.0.0 or later versions of ROP setup software.

## Using FTP client function

To use the FTP client function, network configuration and FTP client settings are necessary in advance.

### FTP client function setting

By connecting the camera to network using wireless LAN (wireless access point connection), 4G/LTE, or wired LAN, you can transfer clips to a server device on the network.

#### Client settings

To transfer clips with the FTP client function, you need to set the connection destination and other settings in advance.

#### 1 Set each item in the main menu → [NETWORK SETUP] → [CLIENT SERVICE].

**[FTP SETTING DATA]:** Sets from where client service settings are acquired.

- **[INTERNAL]:** Uses the settings set on the camera.
- **[SD CARD]:** Uses the settings of the file inside the SD memory card inserted in the SD card slot. When this item is set to [SD CARD], insert an SD memory card before turning on the power of the camera.

**[FTP SERVER URL]:** Sets the name or address of the server to connect to. (Up to 500 characters)

**[LOGIN USER]:** Sets the user ID to connect to. (Up to 31 characters)

**[LOGIN PASSWORD]:** Sets the password to connect to. (Up to 15 characters) The set password cannot be displayed on the unit.

**[SSH]:** Sets when transferring files using SSH. ([ENABLE]: Uses SSH/[DISABLE]: Does not use SSH)

**[SSH PORT]:** Sets the port number when the SSH is used. Set the same number as the server.

#### NOTE

- The FTP client function does not function when [WLAN] is set in the main menu → [NETWORK SETUP] → [NETWORK SEL], and [DIRECT] is set in the main menu → [NETWORK SETUP] → [WIRELESS PROPERTY] → [TYPE].

#### Saving client service settings in the SD memory card

#### 1 Select [SAVE (SD CARD)] in the main menu → [NETWORK SETUP] → [CLIENT SERVICE].

The setting values of [FTP SERVER URL], [LOGIN USER], [LOGIN PASSWORD], [SSH], and [SSH PORT] of the main menu → [NETWORK SETUP] → [CLIENT SERVICE] are saved in the SD memory card.

#### Loading the client service settings from the SD memory card

#### 1 Select [LOAD (SD CARD)] in the main menu → [NETWORK SETUP] → [CLIENT SERVICE].

The client service settings loaded from the SD memory card are reflected on the settings of the camera.

#### Operation check tools, status indication, and initialization

You can check FTP client network connection status as follows.

##### ■ Checking connection (PING)

#### 1 Press the <THUMBNAIL> button.

The thumbnail screen is displayed.

#### 2 Select [PING] in the main menu → [NETWORK SETUP] → [NETWORK TOOLS].

#### 3 Press the control stick.

#### 4 Perform status check of the connection with the address that has been set.

When a connection is confirmed, [PING SUCCESSFUL!] appears.

If a connection cannot be established within approximately 30 seconds, [PING FAILED!] appears. The log may indicate the cause of a failure.

##### ■ Displaying the connection log (LOG)

#### 1 Select [LOG DISPLAY] in the main menu → [NETWORK SETUP] → [NETWORK TOOLS].

#### 2 Press the control stick.

The log appears.

#### 3 After checking the log, press the <EXIT> button.

The setting menu screen returns.

#### NOTE

- Some operations may not generate any information in the log.
- The password is indicated as [\*] in the log.

##### ■ Displaying the status

#### 1 Select [STATUS DISPLAY] in the main menu → [NETWORK SETUP] → [NETWORK TOOLS].

#### 2 Press the control stick.

The connection status is displayed.

**3 After checking the log, press the <EXIT> button.**

The setting menu screen returns.

**NOTE**

- The status information is not updated in real-time. To view the most recent data, perform the procedure again.
- If [ENABLE] is set in the main menu → [NETWORK SETUP] → [LAN PROPERTY] → [DHCP], or in the main menu → [NETWORK SETUP] → [WIRELESS PROPERTY] → [DHCP], IP address and other necessary information are assigned automatically. However, the status information is not displayed correctly while the address information is being obtained.
- The default gateway is displayed as status information only when correctly set up.
- If only [SECONDARY DNS] is set without setting [PRIMARY DNS] for the network setting (wireless LAN, wired LAN), [DNS1] is displayed.

**■ Initializing network settings**

**1 Select [INITIALIZE] in the main menu → [NETWORK SETUP] → [NETWORK TOOLS].**

**2 Press the control stick.**

When initialization completes, the setting menu screen returns.

**FTP server folder list (FTP explorer screen)**

The information and subfolder list of folders in the FTP server can be displayed. You can also display the thumbnail list of a desired CONTENTS folder (folder storing clips of P2 card).

**1 Press the <THUMBNAIL> button.**

The thumbnail screen is displayed.

**2 Select [FTP] in the main menu → [CLIP] → [EXPLORE].**

**3 Press the control stick.**

The FTP explorer screen appears.

**FTP explorer screen**

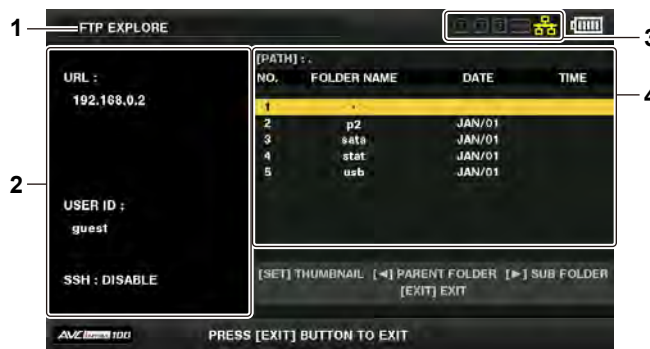

**1 Status indication**  
Indicates that the screen is the FTP explorer screen.

**2 FTP server information**  
[URL]: The address of the connected FTP server  
[USER ID]: ID of the user who has logged in  
[SSH]: [ENABLE]/[DISABLE] indication of [SSH]

**3 Media status**  
Indicates the P2 card insertion status, hard disk connection status, type, and network connection status.  
For the indicators of media status, refer to “Status displays for card slot, storage device, and network connection” (page 107).

**NOTE**

- The display of the network status indicator is updated a few seconds behind the actual state.

**4 Folder information**  
[PATH]: The path of the current folder on the FTP server  
[NO.]: Folder number  
[FOLDER NAME]: Folder name  
[DATE]: Date of last update  
[TIME]: Time of last update

**NOTE**

- The folder list displays only folders, and does not display ordinary files or link files.
- [ . ] indicates the current folder. No date and time information is displayed.
- The date and time information displays either local time or world standard time, which depends on the information from the FTP server. In some cases, only the year or time is displayed.
- Whether text is case sensitive or not depends on the FTP server.
- Folder names using multi-byte characters are not displayed correctly.



- Up to 100 folders can be displayed in one folder. The 101st folder and subsequent folders cannot be accessed from the FTP explorer screen. However, if you have directly entered the folder name in the main menu → [NETWORK SETUP] → [CLIENT SERVICE] → [FTP SERVER URL], you can access the folder even when it is the 101st or later.
- Connectivity and folder appearance may differ from those when connected to an FTP server with a computer, etc.
- Depending on the FTP server and the connection environment, error messages may not be displayed correctly.
- To discontinue the connection procedure, press the control stick.
- If an error occurs, perform the operation again.
- An error may occur when a network operation is performed immediately after inserting a LAN cable or connecting via wireless LAN, or when an operation is performed again immediately after cancelling the previous operation.
- If connection error persists after attempting several times, check the main menu → [NETWORK SETUP] → [NETWORK TOOLS] → [PING]. Note that connection to FTP may succeed even when [PING] fails. If connection cannot be established even after checking with PING, consult your system administrator in charge of your network environment.
- When [PING] fails, check the following items.
  - Network configuration is correct
  - LAN cable is correctly inserted
  - Hubs and routers in the path operates normally
- When connection is not established even after [PING] has succeeded, check the following items.
  - Server function services of the FTP server are running
  - There is not a firewall in the communication path
  - User ID and password that permits access to the FTP server have been set
- Some on-screen operations may not be possible for a while after the use of FTP client function has been cancelled.

**Control stick operation on the FTP explorer screen**

Pushing rightward: Contents of the subfolder at the cursor position are displayed.

Pushing leftward: Contents of higher-level folder to the current folder are displayed.

Pushing upward/downward: The cursor is moved.

Pushing upward/downward while holding down the <SHIFT> button: The cursor is moved to the top/bottom folder on the list.

**NOTE**

- Depending on server operating specifications or access rights setting, folder contents or folder path may not be displayed correctly.
- The cursor position of the previous folder is stored. If an error occurs, the cursor position will be reset to the top folder.
- If a thumbnail has been displayed, only the cursor position in the previously displayed folder list will be stored.

**FTP thumbnail screen**



**1 FTP server/folder information**

[URL]: The address of the connected FTP server

[USER ID]: ID of the user who has logged in

[SSH]: [ENABLE]/[DISABLE] indication of the main menu → [NETWORK SETUP] → [CLIENT SERVICE] → [SSH]

[PATH]: Path in the FTP server of the folder where currently displayed thumbnails are contained

[DATE]: Date of last update

[TIME]: Time of last update

**NOTE**

- When a proxy recording clip is displayed on the FTP explorer screen, [P.only] is displayed on the thumbnail. This is displayed only on proxy clips to indicate that the main recording video and audio data are not included.
- Press the <EXIT> button to return to the explorer screen.
- The 1001st clip and subsequent clips cannot be displayed.
- The date and time information displays either local time or world standard time, which depends on the information from the FTP server.
- Opening thumbnails using [ . ] will not display the date and time of the folder.

**Deleting clips on the FTP server**

Clips on the FTP server that are no longer necessary can be deleted in the same way as clips on P2 cards.

For details, refer to “Deleting clips” (page 113).

**NOTE**

- If you leave the FTP thumbnail screen displayed, the FTP server may be disconnected after a while. After the server has been disconnected, clips cannot be deleted. In this case, return to the FTP explorer screen, display the FTP thumbnail screen again, and then delete clips.



## Viewing information of clips on FTP server

You can view metadata of clips on the FTP server.

The information and the procedure to display are the same as that of P2 card clip properties.

### 1 Move the cursor to the target clip on the FTP thumbnail screen.

The detailed information of a clip can be displayed and checked on the screen.

### 2 Select [CLIP PROPERTY] in the main menu → [CLIP] → [PROPERTY].

### 3 Press the control stick.

#### NOTE

- Metadata can be viewed but cannot be edited.
- If you leave the FTP thumbnail screen or clip properties displayed, the FTP server may be disconnected after a while. After the server has been disconnected, thumbnails may not be able to be displayed. In this case, return to the FTP explorer screen and display the FTP thumbnail screen again.

## Transferring from a P2 card to an FTP server (copy)

Clips on P2 cards can be transferred to the FTP server.

### 1 Press the <THUMBNAIL> button.

The thumbnail screen is displayed.

### 2 Select a clip to be transferred.

### 3 Select [FTP] in the main menu → [CLIP] → [COPY].

If you copy only proxy recording, select [FTP(PROXY)] in the main menu → [CLIP] → [COPY].

### 4 Press the control stick.

The folders of FTP server are displayed.

### 5 Select the transfer destination folder using the control stick.

Press the control stick while pressing the <SHIFT> button (<MULTI SEL>) to create a new folder in the current folder list. Numbers that indicate date and time are automatically entered as the name of the new folder. You can also use the software keyboard to set the folder name. However, some characters cannot be used depending on the FTP server. You cannot set a folder name that is same as an existing folder.

### 6 Move the cursor to [YES] and press the control stick.

Copying starts.

For the procedure to import by clips, refer to “Copying clips” (page 113).

When copying is completed, [COPY COMPLETED!] appears.

#### NOTE

- When a proxy recording clip recorded in the following conditions has been transferred to the FTP server, it is displayed as a divided clip on the server.
  - A clip recorded over the continuous recording time in a memory card
  - A clip recorded across multiple memory cards
  - A clip recorded with one-clip recording
- Folder names using multi-byte characters are not displayed correctly.
- Depending on the number of clips on the server and network conditions, it may take some time to display thumbnails or to copy them.
- To cancel the copy process, use the control stick to place the cursor on [CANCEL] and press the control stick. Select [YES] when a [CANCEL] confirmation message appears, and then press the control stick. If the network has not been disconnected, the partially copied clips at the copy destination are deleted. If the network has been disconnected, incomplete clips may remain on the FTP server.
- Cancelling the copy process may not be possible depending on the network status. In this case, turn <OFF> the camera's power switch to interrupt the copy process.
- After copying starts, disconnection errors will no longer be detected. Cancel the copy operation if the copying progress has stalled.
- Contact your FTP server administrator for the amount of free space on the FTP server in advance, as it cannot be checked automatically before copying starts.
- Whether an error is generated when the remaining capacity of the FTP server reaches 0 depends on the FTP server. If an error is not generated, cancel the copy operation.
- Clips cannot be copied to an FTP server destination folder that contains more than 1000 clips.
- To transfer clips using SSH, the FTP server must support SSH.
- Using SSH will reduce the transfer speed.
- To check the transfer result on a computer or another device, refreshing the display on the computer or another device may be necessary.

## Transferring from an SD card to an FTP server (export)

You can collectively transfer the data in an SD memory card to the FTP server.

### 1 Press the <THUMBNAIL> button.

The thumbnail screen is displayed.

### 2 Select [SD CARD] in the main menu → [CLIP] → [EXPORT].

### 3 Press the control stick.

The folders of FTP server are displayed.

#### 4 Select the transfer destination folder using the control stick.

Press the control stick while pressing the <SHIFT> button (<MULTI SEL>) to create a new folder in the current folder list. Numbers that indicate date and time are automatically entered as the name of the new folder. You can also use the software keyboard to set the folder name. However, some characters cannot be used depending on the FTP server. You cannot set a folder name that is same as an existing folder.

#### 5 Move the cursor to [YES] and press the control stick.

Exporting starts.

When exporting is completed, [COPY COMPLETED!] appears.

---

#### NOTE

- You cannot select clips to be exported.
- Folder names using multi-byte characters are not displayed correctly.
- Depending on factors such as the number of files, file sizes, and network conditions, exporting may take time.
- To cancel the export process, press the control stick. Select [YES] when a [CANCEL] confirmation message appears, and then press the control stick. If the network has not been disconnected, the partially exported files remaining on the FTP server are deleted. If the network has been disconnected, incomplete files may remain on the FTP server.
- After exporting starts, disconnection errors will no longer be detected. Cancel the export operation if the copying progress has stalled.
- Contact your FTP server administrator for the amount of free space on the FTP server in advance, as it cannot be checked automatically before exporting starts.
- Whether an error is generated when the remaining capacity of the FTP server reaches 0 depends on the FTP server. If an error is not generated, cancel the export operation.
- If existing folders are selected and a file that has the same path name as data in the SD memory card is included in the selected folders, the file is overwritten. However, if the path names are the same but the types differ (folder and file), an error is generated.
- To prevent unintended overwriting, create new folders to export data whenever possible.
- To transfer clips using SSH, the FTP server must support SSH.
- Using SSH will reduce the transfer speed.

## Rec during upload function

Clips recorded in the P2 card can be automatically transferred to a server device on the network during recording/playback with the camera.

The rec during upload function has the following two modes:

- Automatic transfer mode: After the rec during upload function is enabled, uploads recorded clips in order.
- Manual selection mode: Uploads clips selected beforehand.

To use the rec during upload function, network settings and FTP client settings need to be configured beforehand.

### Transferring recorded clips automatically (automatic transfer mode)

#### 1 Establish the network connection between the camera and a server device.

Refer to “FTP client function setting” (page 184) for the settings.

#### 2 Set the camera's main menu → [NETWORK SETUP] → [CLIENT SERVICE] → [REC DURING UPLOAD] to [ENABLE].

#### 3 Select the type of clip to upload in the camera's main menu → [NETWORK SETUP] → [CLIENT SERVICE] → [AUTO COPY].

[REC CLIP(PROXY)]: Upload target is proxy data of recorded clips.

[REC CLIP]: Upload target is recorded clips (main recording data and proxy data).

[DISABLE]: Recorded clips are not upload targets.

#### 4 Shoot.

Clips are registered in the upload list immediately after recording is stopped, and then recorded clips are automatically transferred.

The viewfinder or LCD monitor shows the operation status of the rec during upload function. In addition, the thumbnail screen shows the operation status of the rec during upload function and the transfer status of clips.

#### NOTE

- After enabling the rec during upload function, upload of clips will start. To prevent upload error, do not remove the P2 card or SD memory card inserted in the camera.
- Up to 100 clips are registered in the upload list. Clips exceeding 100, except for uploaded clips, cannot be registered.
- While recording is stopped, you can add recorded clips to transfer. From the thumbnail screen, select the main menu → [CLIP] → [COPY] → [FTP] or [FTP(PROXY)], and then select clips to transfer. The selected clips are registered in the upload list.
- Clips are also automatically transferred during recording, playback, and thumbnail display.
- If the network is disconnected during transfer, or the power of the camera is turned off and on again, transfer resumes in clip units.
- During background recording and simultaneous recording, only recorded clips in slot 1 are automatically transferred.
- Clips of interval recording, loop recording, one-clip recording, and one-shot recording are not automatically transferred.
- While the rec during upload function is enabled, the last clip delete function is disabled.
- While the rec during upload function is enabled, the streaming function is disabled.
- While the rec during upload function is enabled, the list of directories on the FTP server is not displayed on the FTP explorer screen.
- While the rec during upload function is enabled, the setting values in the main menu → [NETWORK SETUP] cannot be changed or initialized.

### Transferring selected clips automatically (manual selection mode)



Fig. 1

#### 1 Establish the network connection between the camera and a server device.

Refer to “FTP client function setting” (page 184) for the settings.

#### 2 Set the camera's main menu → [NETWORK SETUP] → [CLIENT SERVICE] → [REC DURING UPLOAD] to [ENABLE].

#### 3 Set the camera's main menu → [NETWORK SETUP] → [CLIENT SERVICE] → [AUTO COPY] to [DISABLE].

#### 4 From the thumbnail screen, select the main menu → [CLIP] → [COPY] → [FTP] or [FTP(PROXY)], and then select clips to transfer. (Fig. 1)

Selected clips are registered in the upload list, and transferred automatically.

You can check the transfer status of clips registered in the upload list in the main menu → [NETWORK SETUP] → [CLIENT SERVICE] → [UPLOAD LIST].

The viewfinder or LCD monitor shows the operation status of the rec during upload function. In addition, the thumbnail screen shows the operation status of the rec during upload function and the transfer status of clips.

**NOTE**

- After enabling the rec during upload function, upload of clips will start. To prevent upload error, do not remove the P2 card or SD memory card inserted in the camera.
- Up to 100 clips are registered in the upload list. Clips exceeding 100, except for uploaded clips, cannot be registered.
- Clips are also automatically transferred during recording, playback, and thumbnail display.
- If the network is disconnected during transfer, or the power of the camera is turned off and on again, transfer resumes in clip units.
- While the rec during upload function is enabled, the last clip delete function is disabled.
- While the rec during upload function is enabled, the streaming function is disabled.
- While the rec during upload function is enabled, the list of directories on the FTP server is not displayed on the FTP explorer screen.
- While the rec during upload function is enabled, the setting values in the main menu → [NETWORK SETUP] cannot be changed or initialized.

**Displaying the upload list**

The upload list allows you to check the transfer status of clips to be uploaded.

**1 Select the main menu → [NETWORK SETUP] → [CLIENT SERVICE] → [UPLOAD LIST].**

The upload list is displayed.

**Upload list screen**

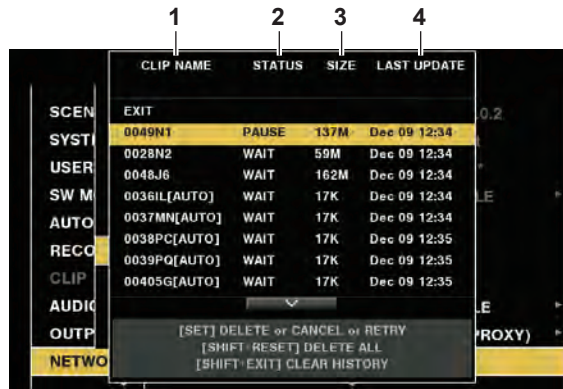

- [CLIP NAME]**  
Displays clip names. For the clip where automatic transfer is set, [AUTO] is displayed after the clip name.
- [STATUS]**  
Displays the upload status.  
[OK]: Uploaded  
[ERROR]: Upload failed  
[PAUSE]: Upload paused  
[UPLOAD]: Uploading  
[WAIT]: Waiting for upload
- [SIZE]**  
Displays the file size.
- [LAST UPDATE]**  
Displays the date and time [STATUS] display changed.

**Operations on the upload list screen**

You can delete, cancel, or re-transfer items from the upload list.

**1 Select an item from the upload list.**

**2 Perform one of the following operations.**

- To delete an item, select [DELETE] with the control stick.
- To cancel upload, select [CANCEL] with the control stick.
- To re-transfer an item, select [RETRY] with the control stick.
- To delete all items, press the <SHIFT> button and the <RESET> button simultaneously. When the confirmation screen is displayed, use the control stick to select [YES].
- To delete history (items of which [STATUS] is [OK] or [ERROR]), press the <SHIFT> button and <EXIT> button at the same time. When the confirmation screen is displayed, select [YES] with the control stick.

**NOTE**

- If the [STATUS] display changes while displaying the upload list, the screen is not updated.
- Save up to the latest 1000 logs for clip information (month and date, clip number (global clip ID), status) registered in the upload list to an SD memory card.

## Chapter 10 **Maintenance and Inspection**

---

Inspect the various parts of the camera before shooting. Maintenance of the camera or frequently asked questions are also described in this chapter.

## Maintenance

---

### Charging the built-in battery

The camera uses the built-in battery to remember the date and time.

If [BACKUP BATT EMPTY] is displayed on the viewfinder or LCD monitor, the built-in battery is running out. Charge the built-in battery with the following procedure.

**1 Make sure that the power switch is <OFF>.**

**2 Connect the AC adaptor to the camera.**

For details on the connection of AC adaptor, refer to "Using the AC adaptor" (page 26).

**3 Leave the camera for approx. four hours.**

The built-in battery will be charged.

After charging completes, set the date and time and check the time code. If [SET DATE AND TIME] is displayed on the viewfinder or LCD monitor, set the date/time of the internal clock. (page 32)

If [BACKUP BATT EMPTY] is still displayed after charging, the built-in battery needs to be replaced. Consult your dealer.

## Frequently asked questions

### Power supply

#### ■ What is the range of voltage supported by the attached AC adaptor?

- AC 110 V - 240 V

#### ■ Can I use the AC adaptor with the battery attached?

- Yes, you can. When you connect the AC adaptor with the battery attached (and the power is turned on), the power supply source will be switched to the AC adaptor.

### Battery

#### ■ Can I use the battery of a previous model that I have been using?

- You can use the battery of P2 hand-held camera recorder of previous models (CGA-D54/CGA-D54s).
- Using the genuine Panasonic battery is recommended.  
Parts No.: VW-VBD58 (7.2 V, 5800 mAh)

#### ■ Can I use the attached battery with charge level indicator with a P2 camera recorder of previous model?

- You cannot use the attached battery with a device other than this camera.

### Shooting

#### ■ The focus is not adjusted automatically.

- Is manual focus mode set? The focus will be adjusted automatically by setting auto focus mode.
- Do you perform shooting in an environment where focus may not be adjusted properly in auto focus mode? In some environment, auto focus function cannot adjust the focus correctly. In such cases, adjust the focus in manual focus mode.

Under following conditions, focus may not be adjusted properly:

- Shooting subjects that is in long and short distances at the same time
- Shooting a subject through a dirty glass
- Shooting in a dark place
- With a glittering object nearby
- Shooting a fast-moving subject
- Shooting a low contrast subject

#### ■ Shooting cannot be performed even when the microP2 memory card or P2 memory card is inserted correctly.

- Recording cannot be performed when the write protect switch on the P2 memory card is at the PROTECT position.
- Recording cannot be performed when the write protect switch on the microP2 memory card is at the LOCK position.
- If the remaining free space of the P2 card is extremely small, save the contents to another medium and delete them, or insert a new card.
- If the P2 card is in a format that cannot be used, reformat the card on the camera.
- Is it a 2 GB P2 memory card? If so, the media information display shows [E] and the card cannot be used.
- Does the number of clips exceed 1000? Clips over 1000 cannot be recorded in a single P2 card. Recording in the one-clip recording mode creates combined clips with multiple clips included. Even when the thumbnail screen shows smaller number of clips, the actual number of clips may be 1000.

#### ■ Loop recording cannot be performed.

- Loop recording can only be performed on the microP2 memory card slot. Also, two cards with at least one minute of free space must be inserted.

### Editing

#### ■ Computer (Windows/Mac) cannot be connected via USB. (The computer does not recognize the camera.)

- Is USB host mode set? The USB host mode is a mode to connect a hard disk to the camera. Set [DEVICE] in the main menu → [NETWORK SETUP] → [USB MODE SELECT].
- Is the USB driver installed? (Windows)  
Download and install the latest USB driver. For Mac, installation of a USB driver for the camera is not necessary.

#### ■ Clips imported to computer or external hard disk drive cannot be recognized on application such as P2 Viewer Plus.

- Check if the clips are correctly saved in the file structure of the P2 system (folders and data contained in the CONTENTS folder).
- If clips in the CONTENTS folder or subfolders are renamed or saved as divided data, the clips may not be able to played back.

### Playback

#### ■ Hot swap playback cannot be performed.

- This camera does not support hot swap playback.

#### ■ Clip copying cannot be performed.

- Clips cannot be copied when they are continuously linked in one-clip recording mode. Press the REC button for two seconds and release the clip linking.

## Others

■ **SD memory card is not recognized.**

- Is the SD memory card is formatted properly? Format the card on the camera.

■ **The camera clatters when tilted forward/backward.**

- When the power switch is <OFF>, the camera may clatter due to the camera part mechanism. This is not a malfunction.

■ **A short click sound occurs when the power is turned on.**

- This is an initial operation of the startup of the lens of the camera recorder. This is due to the camera recorder mechanism and is not a malfunction.

■ **Which lens filter can be attached?**

- You can attach filters with 72 mm diameter that are common for broadcasting or professional use.

■ **Can I use the wired remote controls that I have used with the AG-HPX170 series and AG-HPX250 series?**

- You can basically use them as the control method is the same on the AG-HPX170 series and AG-HPX250 series. If they do not work, contact the manufacturer of the wired remote control.



## Warning system

If an error is detected immediately after the camera is turned on or during operation, the viewfinder, LCD monitor, and tally lamp indicate the error. Deal with the error by following the indications.

### Cases indicated by error codes

Error code	Display	Description	Behavior and cause
[E-30]	[TURN POWER OFF] [P2 CARD]	An error occurred in the camera built-in memory because the P2 card being accessed was ejected. • Tally lamp flashes four times per second.	<ul style="list-style-type: none"> <li>• Cannot operate.</li> <li>• Follow the message to turn off the power once and turn on the power again.</li> <li>• Ensure that there is no error in the clips on the ejected card, and restore the clips as necessary.</li> </ul>
[E-31]	[TURN POWER OFF] [SYSTEM MODE]	System mode error occurred. • Tally lamp flashes four times per second.	<ul style="list-style-type: none"> <li>• Cannot operate.</li> <li>• Follow the message to turn off the power once, turn on the power again, and check that there is no error display.</li> </ul>
[E-33]	[SYSTEM ERROR] [CAMERA]	Camera unit error occurred. • Tally lamp flashes four times per second.	<ul style="list-style-type: none"> <li>• The operation stops.</li> <li>• Contact your dealer.</li> </ul>
[E-35]	[SYSTEM ERROR] [CODEC]	Codec control error occurred. • Tally lamp flashes four times per second.	<ul style="list-style-type: none"> <li>• The operation stops.</li> <li>• Contact your dealer.</li> </ul>
[E-36]	[SYSTEM ERROR] [P2 SYSTEM]	P2 system error occurred. • Tally lamp flashes four times per second.	<ul style="list-style-type: none"> <li>• The operation stops.</li> <li>• Contact your dealer.</li> </ul>
[E-37]	[SYSTEM ERROR] [P2CS]	P2CS microcomputer error occurred. • Tally lamp flashes four times per second.	<ul style="list-style-type: none"> <li>• The operation stops.</li> <li>• Contact your dealer.</li> </ul>
[E-39]	[SYSTEM ERROR] [INITIALIZE]	Video initialization error occurred. • Tally lamp flashes four times per second.	<ul style="list-style-type: none"> <li>• The operation stops.</li> <li>• Contact your dealer.</li> </ul>
[E-64]	[SYSTEM ERROR] [FRAME SIGNAL] (or no display)	Reference signal error occurred. • Tally lamp flashes four times per second.	<ul style="list-style-type: none"> <li>• The operation stops.</li> <li>• Contact your dealer.</li> </ul>

### Cases indicated by error messages

#### During recording/playback

Display	Description	Behavior and cause
[AUTH NG CARD] (slot number)	CPS authentication of microP2 memory card has failed. The microP2 memory card whose CPS authentication failed cannot be recorded or played back.	<ul style="list-style-type: none"> <li>• The current operation will continue.</li> <li>• Select [AUTHENTICATE] in the main menu → [CLIP], and enter the password.</li> </ul>
[BACKUP BATT EMPTY]	Displays any reduced voltage detected on the backup battery in the internal clock when the power is turned on.	<ul style="list-style-type: none"> <li>• The current operation will continue.</li> <li>• Charge the built-in battery.</li> </ul>
[SET DATE AND TIME]	Displayed when the internal clock setting is reset.	<ul style="list-style-type: none"> <li>• The current operation will continue.</li> <li>• Set the date/time of the internal clock. (page 32)</li> </ul>
[CARD ERROR] (slot number)	Displayed when an data error caused by the P2 card occurs during recording. Displayed after recording stops until the next operation. Also displayed for three seconds during playback when a P2 card error causes playback to stop. • If the error occurs during recording, the tally lamp flashes four times per second for approx. three seconds after recording stops. • The tally lamp does not flash when an error occurs during playback.	<ul style="list-style-type: none"> <li>• The operation will stop.</li> <li>• After it stops, the P2 card on which the error occurred is write-protected. Replace the P2 card of the slot where the error occurred.</li> </ul>
[DIR NG CARD] (slot number)	The directory position is not correct.	<ul style="list-style-type: none"> <li>• The current operation will continue.</li> <li>• Make a card backup immediately and format the card to use it again.</li> </ul>
[FAN STOPPED]	Displayed when the fan motor stops.	<ul style="list-style-type: none"> <li>• The current operation will continue.</li> <li>• If the fan has stopped with error, stop using the camera immediately and consult your dealer.</li> <li>• If the fan has stopped, temperature of the camera will rise. Therefore, do not use the camera for a long period of time.</li> </ul>
[HIGH TEMPERATURE]	The temperature inside the camera is higher than that of the normal conditions.	<ul style="list-style-type: none"> <li>• The current operation will continue.</li> <li>• Turn off the power of the camera, turn it on again, and check recording and playback operations. If the problem persists, consult your dealer.</li> </ul>
[PB INTERMITTENT] (slot number)	Playback is interrupted on the SDHC/SDXC memory card. A card whose playback performance cannot be assured is inserted.	<ul style="list-style-type: none"> <li>• The current operation will continue.</li> <li>• Use of microP2 or P2 memory card is recommended.</li> </ul>

## Chapter 10 Maintenance and Inspection — Warning system

Display	Description	Behavior and cause
[PROXY ERROR]	An error occurred in the internal proxy module.	<ul style="list-style-type: none"> <li>The current operation will continue.</li> <li>Turn off the camera and turn on it again to check the recording and playback. If the error continues to occur, please consult your dealer.</li> </ul>
[PROXY REC WARNING]	A proxy data recording error occurred.	<ul style="list-style-type: none"> <li>The current operation will continue.</li> <li>Turn off the camera and turn on it again to check the recording and playback. If the error continues to occur, please consult your dealer.</li> </ul>
[REC IMPOSSIBLE] (slot number)	An SDHC/SDXC memory card is inserted into the microP2 memory card slot. Recording to the SDHC/SDXC memory card is disabled.	<ul style="list-style-type: none"> <li>The current operation will continue.</li> <li>Record to microP2 or P2 memory cards.</li> </ul>
[REC WARNING] [FRAME SIGNAL]	Displayed when a video or audio error occurs during recording. <ul style="list-style-type: none"> <li>Tally lamp flashes four times per second during continuous recording.</li> </ul>	<ul style="list-style-type: none"> <li>The current operation will continue. When input signals are disrupted, recording continues while disrupted images are recorded. Check the signal to be input to the camera.</li> <li>Turn off the power and on before using it again.</li> </ul>
[REC WARNING] [OVER MAX# CLIPS]	Displayed when attempting to record in excess of the maximum total number of clips allowed for one P2 card. <ul style="list-style-type: none"> <li>Tally lamp flashes four times per second during continuous recording.</li> </ul>	<ul style="list-style-type: none"> <li>The operation will stop.</li> <li>Replace the P2 card or delete unnecessary clips.</li> </ul>
[REC WARNING] [PULL DOWN]	(Occurs during recording) The video pull-down sequence and time code values are not synchronized. <ul style="list-style-type: none"> <li>Tally lamp flashes four times per second during continuous recording.</li> </ul>	<ul style="list-style-type: none"> <li>The current operation will continue.</li> <li>Check the signal.</li> </ul>
[REC WARNING] [PULL DOWN ERROR]	(Occurs at times other than during recording) The video pull-down sequence and time code values are not synchronized.	<ul style="list-style-type: none"> <li>The current operation will continue.</li> <li>Check the signal.</li> </ul>
[REC WARNING] [REC DATA]	Displayed when an error occurs in recorded data during recording. <ul style="list-style-type: none"> <li>Tally lamp flashes four times per second during continuous recording.</li> </ul>	<ul style="list-style-type: none"> <li>The operation will continue or stop.</li> <li>Turn off the power and on before using it again.</li> </ul>
[RUN DOWN CARD] (slot number)	The maximum number of overwrites has been exceeded.	<ul style="list-style-type: none"> <li>The current operation will continue.</li> <li>Replacement of the P2 card is recommended.</li> </ul>
[SD CARD] (slot number)	An SDHC/SDXC memory card is inserted into the microP2 memory card slot.	<ul style="list-style-type: none"> <li>The current operation will continue.</li> <li>Use of microP2 or P2 memory card is recommended.</li> </ul>
[SLOT3 CANNOT REC] [microP2 SELECTED]	Displayed when the card is inserted into the slot which is not selected as the recording slot.	<ul style="list-style-type: none"> <li>The operation will stop.</li> <li>Set [P2] in the main menu → [RECORDING SETUP] → [REC MEDIA].</li> </ul>
[SLOT3/4 CANNOT REC] [P2 SELECTED]	Displayed when the card is inserted into the slot which is not selected as the recording slot.	<ul style="list-style-type: none"> <li>The operation will stop.</li> <li>Set [microP2] in the main menu → [RECORDING SETUP] → [REC MEDIA].</li> </ul>
[TEMPORARY PAUSE] [IRREGULAR SIG]	Correct recording is not possible due to disruption of input signals of the <GENLOCK IN/VIDEO OUT> or <SDI IN> terminal, etc., and recording is suspended temporarily. The clip will be divided. <ul style="list-style-type: none"> <li>Tally lamp flashes four times per second during continuous recording.</li> </ul>	<ul style="list-style-type: none"> <li>The operation will pause.</li> <li>Recording resumes when the signal returns to normal. However, during loop recording, recording does not resume.</li> </ul>
[VFR ON, NO AUDIO RECORDING]	Native variable frame rate recording is performed. Audio can not be recorded.	<ul style="list-style-type: none"> <li>The current operation will continue.</li> </ul>

### During thumbnail and menu operation

Display	Description	Behavior and cause
[AUTHENTICATION ERROR!]	Manual authentication failed.	Enter the correct password.
[CANNOT ACCESS!]	Data cannot be accessed due to a content defect or some other reason.	Ensure the health of the media and the clips.
[CANNOT CHANGE!]	For a clip with the  mark, where a thumbnail cannot be generated, the thumbnail cannot be modified in the text memo position.	Correct the settings and content to enable display of the thumbnail.
[CANNOT DELETE!]	The content versions do not match. Cannot delete.	Match the device and contents version.
[CANNOT FORMAT!]	A P2 card problem or some other reason prevents formatting.	Check the P2 card.
[CANNOT RE-CONNECT!]	Clips cannot be remerged because either clips not recorded across multiple P2 cards are selected or other reasons.	Check the selected content.
[CANNOT REPAIR IN SELECTION!]	Some of the selected clips cannot be repaired.	Check the selected content.
[CANNOT REPAIR!]	Content that cannot be repaired is selected.	Check the selected content.
[CANNOT SAVE! FILE NAME IN USE]	A settings file of the same name exists on the SD memory card.	Use another name to save the file.
[CARD FULL!]	The P2 card or SD memory card is full.	Insert a card with free space available.

## Chapter 10 Maintenance and Inspection — Warning system

Display	Description	Behavior and cause
[COPY IMPOSSIBLE. TOO LARGE CLIP CONTAINED! (CLIP NAME: XXXXXX)]	Files exceeding 4 GB cannot be copied to P2 memory card or microP2 memory card with 32 GB or smaller capacity.	Copy to a microP2 memory card with 32 GB or larger capacity.
[INVALID VALUE!]	The data value you entered is invalid.	Enter data within the normal range.
[LACK OF CAPACITY!]	There is not enough recording capacity left on the card.	Insert a card with sufficient recording capacity.
[MISSING CLIP!]	Shot marks cannot be attached to the clips unless all clips recorded over multiple P2 cards are present.	Insert all P2 cards over which recording extended.
[NO CARD!]	No P2 or SD memory card is inserted.	Insert the relevant media.
[NO COPY TO SAME CARD!]	A clip cannot be copied to the card storing the original clip.	Copy the selected clip to a card that does not contain the original clip.
[NO FILE!]	The specified file does not exist.	Check the file.
[NO INPUT!]	No data is entered.	Enter data and then set.
[NO SD CARD!]	No SD memory card.	Insert an SD memory card.
[NOT SELECTED!]	Attempted to delete without selecting clips.	Select clips to delete.
[SAME CLIP IS SELECTED!]	Multiple instances of the same clip (copies) are included in the clips selected.	Multiple instances of the same clip (copies) cannot be copied simultaneously. Remove instances of the same clip from selected items.
[TOO MANY CLIPS!]	Too many clips are selected.	Reduce the number of selected clips.
[UNKNOWN CONTENTS FORMAT!]	This is a warning of the contents for the version that is not supported by the camera.	Match the device and content versions.
[UNKNOWN DATA!]	The metadata character code is invalid.	The metadata character code is UTF-8. Enter valid characters using a viewer.
	There is a problem with data in the file.	Create the file again.
[USER CLIP NAME MODIFIED!]	When adding a counter value to the clip name, characters must be deleted.	For the counter addition setting, the user clip name plus the counter value can only contain up to 100 bytes. Characters in the clip name are automatically deleted when the total number of characters exceeds this limit.
[WRITE PROTECTED!]	The P2 card or SD memory card is write-protected.	Insert write-accessible media.

### During soft keyboard operation

Display	Description	Behavior and cause
[AUTHENTICATION ERROR!]	Manual authentication failed.	Enter the correct password.
[CANNOT CHANGE!]	An attempt is made to enter the [PERSON] item (user who enters the memo) when there is no text memo.	Enter the [TEXT] (text information) first.
[CANNOT SET!] [INVALID VALUE!]	The entered value is invalid.	Change the input value.
[CANNOT SET!] [NO INPUT!]	There is not input to the software keyboard.	Enter the password.
[CANNOT SET!] [RETRY PASSWORD IS DIFFERENT!]	The re-entered password is different.	Enter the correct reference password.

### During USB host mode

Message	Description	Measure
[CANNOT ACCESS CARD!]	An error occurred while accessing the P2 card.	Check the P2 card.
[CANNOT ACCESS TARGET!]	An error occurred while accessing the connection target.	Check the storage device status and connection.
[CANNOT COPY! FORMAT STORAGE DEVICE TO FAT]	The partition that can copy clips does not exist on the storage device.	Reformat in FAT format, or export the P2 card to create a partition.
[CANNOT FORMAT!]	The storage device cannot be formatted.	Change the connected storage device.
[CANNOT RECOGNIZE STORAGE DEVICE!]	The storage device is not correctly recognized.	Reboot the storage device or connect another storage device.
[CANNOT SELECT! MAX.6 PARTITIONS]	Storage devices with more than six partitions cannot be selected (mounted simultaneously).	Release selected partitions.
[CARD IS EMPTY! CANNOT COPY!]	The P2 card to copy is empty.	The copy operation is not performed because the card is empty.
[FORMAT P2 CARD!]	Cannot import to a P2 card containing clips.	Format the P2 card.
[LACK OF CAPACITY!]	Not enough space left on the storage device.	Use a new storage device with sufficient available space or a formatted storage device.
[MISMATCH COMPONENT!]	The P2 card model number of the copy source and copy destination do not match. Cannot copy.	Use the P2 cards of the same model number, or import on a clip basis.
[STORAGE DEVICE DISCONNECTED!]	The connection with the storage device is disconnected.	Reconnect the USB cable to the <USB3.0 HOST> terminal. When it does not function normally after that, turn off the power once and turn on the power again.
[TOO MANY PARTITIONS!]	There are too many partitions.	The maximum number of partitions on the storage device is 23. Either reformat, or use a new storage device.

## Chapter 10 Maintenance and Inspection — Warning system

Message	Description	Measure
[UNKNOWN DEVICE CONNECTED!]	A non-compatible DVD drive or other device is connected.	Change the connected device to the correct storage device, and then turn off the power once and turn on it again.
[VERIFICATION FAILED!]	The compare check performed after copying failed.	Copy it again.

### Network

Message	Description	Measure
[CANNOT CONNECT!]	A connection to the network cannot be established.	Check that the LAN settings are correct. Check that the LAN cable is connected correctly and the network you use is running.
[CANNOT FIND FTP-SERVER!]	The connection destination FTP server cannot be found.	Check that the setting in the main menu → [NETWORK SETUP] → [CLIENT SERVICE] → [FTP SERVER URL] is correct.
[LOGIN FAILED!]	Logging in to the connection destination FTP server failed.	Check that the settings in the main menu → [NETWORK SETUP] → [CLIENT SERVICE] → [LOGIN USER] and [LOGIN PASSWORD] are correct.
[PING FAILED!]	The [PING] failed.	Check that the LAN setting and the setting in the main menu → [NETWORK SETUP] → [CLIENT SERVICE] → [FTP SERVER URL] are correct. Check that the LAN cable is connected correctly and the network you use is running.
[CANNOT ACCESS GATEWAY!]	The gateway server cannot be accessed.	Check that the LAN settings are correct.
[CHECK LAN SETTING]	The gateway server cannot be accessed.	Check that the LAN settings are correct.
[IP ADDRESS IS USED!]	The set IP address is being used by another device.	Consult your network administrator and set another IP address.
[INVALID VALUE!]	The entered data value is invalid.	Enter data in a valid range.

## Updating the camera firmware

---

There are two ways to update the firmware:

**1 Use the dedicated tool P2\_Status\_Logger to check and apply the update.**

Only customers registered as members to PASS (P2 Asset Support System) can log in to PASS to use the dedicated (P2\_Status\_Logger) tool.

With P2\_Status\_Logger, you can check the version information of the device used and jump to the page to download the required firmware.

For details about downloading and using P2\_Status\_Logger, refer to the pages displayed after logging in to PASS.

Other benefits are offered to registered users. For details, refer to the website ([http://panasonic.biz/sav/pass\\_e](http://panasonic.biz/sav/pass_e)) of PASS (P2 Asset Support System).

**2 Check the version using the camera and apply the update**

Check the version of the camera in the main menu → [DIAGNOSTIC] → [VERSION], access the latest information on the firmware from the website described in NOTE, and then download the firmware as needed.

 **NOTE**

---

- Update completes by loading the downloaded files to the camera via the SD memory card. For details on update, visit the support desk at the following website:

<http://pro-av.panasonic.net/>

## Cleaning and storing

### Cleaning the camera recorder

- Either remove the battery or disconnect the AC cable from the power outlet before cleaning.
- Do not use benzine or thinner to clean the camera. Using benzine or thinner may cause deformation or peeling off of the paint of the camera recorder body.
- Wipe the camera recorder with a soft and clean cloth. If there is heavy dirt attached, wipe the camera recorder using a cloth soaked in kitchen detergent diluted with water, and then wipe it with a dry cloth.

### Cautions when storing the camera recorder

Remove the battery when storing the camera recorder. Store them in a place where humidity is low and temperature is relatively constant.

- Recommended temperature: 15 °C to 25 °C
- Recommended relative humidity: 40% to 60%

#### ■ Camera recorder

- Wrap the camera recorder with a soft cloth so that dust does not get into it.

#### ■ Battery

- The battery life shortens where the temperature is extremely high or low.
- Storing in a place where there is heavy oil smoke or dust may lead to malfunctions due to rust on terminal connectors, etc.
- Do not let the battery terminal contact a metal object (such as a necklace or hairpin). Short circuit may occur between terminals and it may lead to heat generation. Touching on a heated part may cause severe burns.
- Store the battery with electrically discharged. If you store it for a long period of time, it is recommended that you charge it once a year, use the camera recorder until the battery runs out, and then storing it again.

#### ■ P2 memory card

- If you remove it from the camera recorder, be sure to attach the dedicated cap so that sand and dust do not adhere to the connector part. Also, put it in the dedicated case when storing or carrying it.
- Do not place it in a place where there is corrosive gas.

#### ■ microP2 memory card, SD memory card

- If you remove it from the camera recorder, be sure to put it in its case.
- Do not place it in a place where there is corrosive gas.
- Do not place it in a place where temperature gets high, such as in a car or under direct sunlight.
- Do not place it in a dusty place or where humidity is high.

## Chapter 11 **Specification**

---

This chapter describes the specifications of this product.

# Specifications

## Dimensions

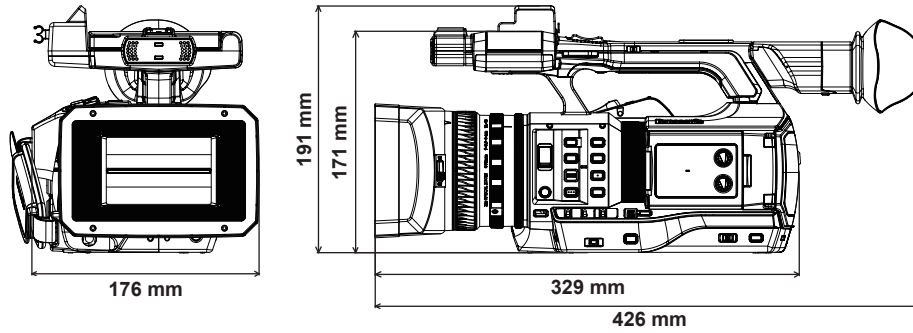

## Specifications

### General

Power  
 DC 7.2 V (when the battery is used)  
 DC 12 V (when the AC adaptor is used)  
 Power consumption  
 19.5 W (when the LCD monitor is used)

indicates safety information.

Ambient operating temperature	0 °C - 40 °C
Ambient operating humidity	10% - 80% (no condensation)
Weight	Approx. 2.2 kg (body only, excluding lens hood, battery, and accessories) Approx. 2.6 kg (including lens hood, supplied battery, and microphone holder)
Dimensions (W×H×D)	Body only 176 mm×171 mm×329 mm (excluding protrusion)

### Camera unit

Pickup device	1/3-type 2.2 million pixels, MOS solid state image sensor ×3
Lens	Optical image stabilizer lens, optical 22x motorized zoom F1.6 - F3.2 (f=3.9 mm - 86 mm) 35 mm conversion: 28 mm - 616 mm (16:9)
Filter diameter	72 mm
Color separation optical system	Prism system
ND filter	<OFF>, <1/4>, <1/16>, <1/64>
Shortest shooting distance (M.O.D)	1.1 m from the lens
Gain setting	<L>/<M>/<H> selector switch -3 dB - 18 dB (in 1 dB steps) (Negative value of gain is only in [HIGH SENS.] mode.) (When assigning [S.GAIN] to the USER button: Switching between 24 dB, 30 dB, and 36 dB)
Color temperature setting	[ATW], [ATW LOCK], [Ach], [Bch], preset 3200 K/preset 5600 K/VAR (2000 K to 15000 K)
Shutter speed	When [SYSTEM MODE] = 59.94 Hz • 60i/60p mode: 1/60 (shutter off), 1/100, 1/120, 1/250, 1/500, 1/1000, 1/2000 sec. • 30p mode: 1/30, 1/50 (shutter off), 1/60, 1/120, 1/250, 1/500, 1/1000, 1/2000 sec. • 24p mode: 1/24, 1/50 (shutter off), 1/60, 1/120, 1/250, 1/500, 1/1000, 1/2000 sec. When [SYSTEM MODE] = 50 Hz • 50i/50p mode: 1/50 (shutter off), 1/60, 1/120, 1/250, 1/500, 1/1000, 1/2000 sec. • 25p mode: 1/25, 1/50 (shutter off), 1/60, 1/120, 1/250, 1/500, 1/1000, 1/2000 sec.



## Chapter 11 Specification — Specifications

Slow shutter speed	<p>Setting is possible when [VFR]=[OFF]                      When [SYSTEM MODE] = 59.94 Hz</p> <ul style="list-style-type: none"> <li>• 60i/60p mode: 1/1, 1/2, 1/4, 1/6, 1/15, 1/30 sec.</li> <li>• 30p mode: 1/1, 1/2, 1/4, 1/6, 1/15 sec.</li> <li>• 24p mode: 1/1, 1/2, 1/4, 1/6, 1/12 sec.</li> </ul> <p>When [SYSTEM MODE] = 50 Hz</p> <ul style="list-style-type: none"> <li>• 50i/50p mode: 1/1, 1/2, 1/4, 1/6, 1/12, 1/25 sec.</li> <li>• 25p mode: 1/1, 1/2, 1/4, 1/6, 1/12 sec.</li> </ul>
Synchro scan shutter	<p>When [SYSTEM MODE] = 59.94 Hz and [SYNC SCAN TYPE] = [sec]</p> <ul style="list-style-type: none"> <li>• 60i/60p mode: 1/60.0 – 1/249.8 sec.</li> <li>• 30p mode: 1/30.0 – 1/249.8 sec.</li> <li>• 24p mode: 1/24.0 – 1/249.8 sec.</li> </ul> <p>When [SYSTEM MODE] = 50 Hz and [SYNC SCAN TYPE] = [sec]</p> <ul style="list-style-type: none"> <li>• 50i/50p mode: 1/50.0 – 1/250.0 sec.</li> <li>• 25p mode: 1/25.0 – 1/250.0 sec.</li> </ul>
Shutter open angle	3.0 deg – 180.0 deg – 360.0 deg (in 0.5 deg steps, angle display)
VFR recording frame rate	<ul style="list-style-type: none"> <li>• 1080/59.94p: 1, 2, 4, 6, 9, 12, 15, 18, 20, 21, 22, 24, 25, 26, 27, 28, 30, 32, 34, 36, 40, 44, 48, 54, and 60 (frames per second)</li> <li>• 1080/50p: 1, 2, 4, 6, 9, 12, 15, 18, 20, 21, 22, 23, 24, 25, 26, 27, 28, 30, 32, 34, 37, 42, 45, 48, and 50 (frames per second)</li> </ul>
Sensitivity	<ul style="list-style-type: none"> <li>• [HIGH SENS.] mode                      F11 (2000 lx, 3200 K, 89.9% reflection, 1080/59.94i)                      F12 (2000 lx, 3200 K, 89.9% reflection, 1080/50i)</li> </ul>
Minimum subject illumination	0.02 lx (F1.6, gain 18 dB, [1S.EXP.], [HIGH SENS.] mode)
Digital zoom	x2/x5/x10
Lens hood	Hood with lens cover

### Memory card recorder

Recording media	microP2 memory card, P2 memory card
Recording slot	microP2 memory card slot ×2, P2 memory card slot ×1
System format	1080/59.94p, 1080/59.94i, 1080/23.98PsF, 720/59.94p, 480/59.94i 1080/50p, 1080/50i, 720/50p, 576/50i
Recording format	AVC-Intra 200/AVC-Intra 100/AVC-Intra 50 AVC-LongG 50/AVC-LongG 25/AVC-LongG 12 Switching DVCPRO HD/DVCPRO50/DVCPRO/DV formats
Recording video signal	1080/59.94p, 1080/59.94i, 1080/29.97pN, 1080/23.98pN 720/59.94p, 720/29.97pN, 720/23.98pN 480/59.94i, 480/29.97p 1080/50p, 1080/50i, 1080/25pN 720/50p, 720/25pN 576/50i, 576/25p

## Chapter 11 Specification — Specifications

Recording and playback time	<ul style="list-style-type: none"> <li>• AVC-Intra 200               <ul style="list-style-type: none"> <li>16 GB×1 approx. 8 min</li> <li>32 GB×1 approx. 16 min</li> <li>64 GB×1 approx. 32 min</li> </ul> </li> <li>• AVC-Intra 100/DVCPRO HD               <ul style="list-style-type: none"> <li>16 GB×1 approx. 16 min</li> <li>32 GB×1 approx. 32 min</li> <li>64 GB×1 approx. 64 min</li> </ul> </li> <li>• AVC-Intra 50/AVC-LongG 50/DVCPRO50               <ul style="list-style-type: none"> <li>16 GB×1 approx. 32 min</li> <li>32 GB×1 approx. 64 min</li> <li>64 GB×1 approx. 128 min</li> </ul> </li> <li>• AVC-LongG 25/DVCPRO/DV               <ul style="list-style-type: none"> <li>16 GB×1 approx. 64 min</li> <li>32 GB×1 approx. 128 min</li> <li>64 GB×1 approx. 256 min</li> </ul> </li> <li>• AVC-LongG 12               <ul style="list-style-type: none"> <li>16 GB×1 approx. 120 min</li> <li>32 GB×1 approx. 240 min</li> <li>64 GB×1 approx. 480 min</li> </ul> </li> </ul>
	Figures are for continuous recording as one clip. Depending on the number of clips, the overall recording time may be shorter than the above.

### Digital video

Sampling frequency	<ul style="list-style-type: none"> <li>• AVC-Intra 200/AVC-Intra 100/AVC-Intra 50/AVC-LongG 50/AVC-LongG 25/AVC-LongG 12/DVCPRO HD               <ul style="list-style-type: none"> <li>Y: 74.1758 MHz, P<sub>B</sub>/P<sub>R</sub>: 37.0879 MHz (59.94 Hz)</li> <li>Y: 74.2500 MHz, P<sub>B</sub>/P<sub>R</sub>: 37.1250 MHz (50 Hz)</li> </ul> </li> <li>• DVCPRO50               <ul style="list-style-type: none"> <li>Y: 13.5 MHz, P<sub>B</sub>/P<sub>R</sub>: 6.75 MHz</li> </ul> </li> <li>• DVCPRO               <ul style="list-style-type: none"> <li>Y: 13.5 MHz, P<sub>B</sub>/P<sub>R</sub>: 3.375 MHz</li> </ul> </li> </ul>
Quantizing	<ul style="list-style-type: none"> <li>• AVC-Intra 200/AVC-Intra 100/AVC-Intra 50/AVC-LongG 50/AVC-LongG 25:               <ul style="list-style-type: none"> <li>10 bits</li> </ul> </li> <li>• AVC-LongG 12/DVCPRO HD/DVCPRO50/DVCPRO/DV:               <ul style="list-style-type: none"> <li>8 bits</li> </ul> </li> </ul>
Video compression format	<ul style="list-style-type: none"> <li>• AVC-Intra 200/AVC-Intra 100/AVC-Intra 50:               <ul style="list-style-type: none"> <li>MPEG-4 AVC/H.264 Intra Profile</li> </ul> </li> <li>• AVC-LongG 50/AVC-LongG 25/AVC-LongG 12:               <ul style="list-style-type: none"> <li>MPEG-4 AVC/H.264</li> </ul> </li> <li>• DVCPRO HD:               <ul style="list-style-type: none"> <li>DV-Based Compression (SMPTE 370M)</li> </ul> </li> <li>• DVCPRO50/DVCPRO:               <ul style="list-style-type: none"> <li>DV-Based Compression (SMPTE 314M)</li> </ul> </li> <li>• DV:               <ul style="list-style-type: none"> <li>DV Compression (IEC 61834-2)</li> </ul> </li> </ul>

### Digital audio

Recording audio signal	<ul style="list-style-type: none"> <li>• AVC-Intra 200               <ul style="list-style-type: none"> <li>48 kHz/24 bits, 4CH</li> </ul> </li> <li>• AVC-Intra 100/ AVC-Intra 50:               <ul style="list-style-type: none"> <li>48 kHz/16 bits, 4CH and 48 kHz/24 bits, 4CH switch</li> </ul> </li> <li>• AVC-LongG 50/AVC-LongG 25:               <ul style="list-style-type: none"> <li>48 kHz/24 bits, 4CH</li> </ul> </li> <li>• AVC-LongG 12/DVCPRO HD/DVCPRO50:               <ul style="list-style-type: none"> <li>48 kHz/16 bits, 4CH</li> </ul> </li> <li>• DVCPRO/DV:               <ul style="list-style-type: none"> <li>48 kHz/16 bits, 4CH</li> </ul> </li> </ul>
Headroom	12 dB/18 dB/20 dB switchable menu

### AVC proxy

File format	MOV
Video compression format	H.264/AVC Baseline Profile H.264/AVC High Profile
Audio compression format	AAC-LC Linear PCM

## Chapter 11 Specification — Specifications

Approximate recording time (1 GB)	<ul style="list-style-type: none"> <li>• AVC-G6 2CH MOV: Approx. 13 min</li> <li>• SHQ 2CH MOV: Approx. 25 min</li> <li>• HQ 2CH MOV: Approx. 78 min</li> <li>• LOW 2CH MOV: Approx. 135 min</li> </ul>
	These are reference values for continuous recording using the Panasonic products. The recording time may differ depending on the scene or the number of clips.

### Video input/output

<SDI OUT> terminal	BNC×1 HD (3G/1.5G), SD: 0.8 V [p-p], 75 Ω
<VIDEO OUT> terminal	BNC×1 Also used as the <GENLOCK IN> terminal, <IN/OUT> switch selection Composite: 1.0 V [p-p], 75 Ω
<HDMI OUT> terminal	HDMI×1 (HDMI type A terminal, not compatible with VIERA Link)

### Audio input

Built-in microphone	Supports stereo microphone
<AUDIO INPUT 1>/<AUDIO INPUT 2> terminal	XLR×2, 3-pin Input high impedance, <LINE>/<MIC> switch selection <ul style="list-style-type: none"> <li>• &lt;LINE&gt;: 4/0 dBu (selectable menu)</li> <li>• &lt;MIC&gt;: -40/-50/-60 dBu (selectable menu), &lt;+48V&gt; on/off (switch selection)</li> </ul>

### Audio output

<AUDIO OUT> terminal	3.5 mm diameter stereo mini jack ×1 Output level: 600 Ω, 316 mV
Headphones terminal	3.5 mm diameter stereo mini jack ×1 100 Ω, -16 dBV (32 Ω load, at maximum output level)
Speaker	20 mm diameter, round ×1

### Other input/output

<CAM REMOTE> terminal	2.5 mm diameter super mini jack ×1 <ZOOM S/S> 3.5 mm diameter mini jack ×1 <FOCUS IRIS>
<GENLOCK IN> terminal	BNC×1, also used as the <VIDEO OUT> terminal, <IN/OUT> switch selection, 1.0 V [p-p], 75 Ω
<TC IN/OUT> terminal	BNC×1 Used as the input and output terminals, <IN/OUT> switch selection <ul style="list-style-type: none"> <li>• Input: 1.0 V - 4.0 V [p-p], 10 kΩ</li> <li>• Output: 2.0 V±0.5 V [p-p], low impedance</li> </ul>
<LAN> terminal	100BASE-TX/10BASE-T
<USB2.0 DEVICE> terminal (device)	Type miniB connector, 4-pin
<USB3.0 HOST> terminal (host)	Type A connector, 9-pin
<USB2.0 HOST> terminal (sub-host)	Type A connector, 4-pin (exclusively for wireless module AJ-WM30)
<DC IN 12V> terminal	DC 12 V (DC 10.5 V - 13.5 V), EIAJ type 4

### Monitor

LCD monitor	3.5-type QHD color monitor (Approx. 1560000 dots)
Viewfinder	0.5-type OLED (organic EL display) (Approx. 2360000 dots, video display area: approx. 1770000 dots)

### AC adaptor

**Power source**

AC 110 V - 240 V, 50 Hz/60 Hz  
42 W

**Power output**

DC 12 V, 2.5 A

indicates safety information.

Ambient operating temperature	0 °C - 40 °C
Ambient operating humidity	10% - 80% (no condensation)
Weight	Approx. 210 g
Dimensions (W×H×D)	115 mm×37 mm×57 mm

Inrush current, measured according to European standard EN55103-1: 4.85 A

### Battery charger

**Power source**

AC 100 V - 240 V, 50 Hz/60 Hz  
0.4 A

**Power output**

DC 8.4 V, 1.2 A

indicates safety information.

Ambient operating temperature	0 °C - 40 °C
Ambient operating humidity	10% - 80% (no condensation)
Weight	Approx. 160 g
Dimensions (W×H×D)	70 mm×44.5 mm×116 mm

Inrush current, measured according to European standard EN55103-1: 5 A

## Index

- A**
- AC adaptor
    - Attaching ..... 26
    - Removal ..... 27
  - Adjusting image quality ..... 54
  - Area mode function ..... 48
  - ATW ..... 51
  - Audio input ..... 62
  - [AUDIO SETUP] ..... 140
  - Audio the recording level ..... 63
  - [AUTO SW] ..... 135
  - Auto tracking white balance ..... 51
  - [AWB PRE CONTROL] ..... 149
- B**
- Background recording ..... 68
  - Backlight compensation ..... 72
  - Battery
    - Attaching ..... 26
    - Charging ..... 25
    - Removing ..... 26
  - Black balance ..... 51
  - Black control function ..... 56
  - Brightness adjustment ..... 46
  - Built-in battery ..... 192
  - Built-in microphone ..... 62
- C**
- [CAM REMOTE ADJ.] ..... 149
  - [CARD FUNCTIONS] ..... 146
  - Center marker ..... 71
  - Chroma setting function ..... 55
  - Clip
    - Copying ..... 113
    - Deleting ..... 113
    - Metadata ..... 114
    - Playback ..... 106
    - Properties ..... 117
    - Reconnecting ..... 113
    - Restoring ..... 113
  - [CLIP] ..... 138
  - Clock ..... 32
  - Color bars ..... 72
  - Color correction function ..... 56
  - Counter ..... 104
  - CPS ..... 36
- D**
- Date and time ..... 32
  - Deleting last clip function ..... 73
  - Detail function ..... 54
  - [DIAGNOSTIC] ..... 147
  - Direct menu operation ..... 73
  - [DISPLAY SETUP] ..... 144
  - Dual codec recording ..... 83
  - Dynamic range stretcher function ..... 37, 72
- E**
- Electronic shutter ..... 58
  - [ENG SECURITY] ..... 149
  - Error code ..... 195
  - Error message ..... 195
  - Expanded display ..... 47
  - Eye cup ..... 29
  - Eye sensor ..... 40
- F**
- FBC ..... 59
  - Flash band compensation ..... 59
  - Focus assist ..... 47
  - Focus bar display ..... 48
  - Focus in red display ..... 47
  - Formatting
    - P2 card ..... 116
    - SD memory card ..... 90, 116
    - Storage device ..... 164
  - Frame marker ..... 72
  - Front microphone ..... 30
  - FTP client function ..... 184
- G**
- Gain ..... 46
  - Gamma function ..... 56
  - Genlock ..... 94
  - GPS ..... 64
  - Grip strap ..... 28
- H**
- Headphones ..... 160
  - High color function ..... 57
  - Hot swap recording ..... 69
- I**
- Image size ..... 72
  - Image stabilization function ..... 72
  - Interval recording ..... 65
  - Iris ..... 46
- K**
- Knee function ..... 56
- L**
- LCD monitor ..... 39
    - Displaying screen ..... 151
    - Status display ..... 151
  - Lens cover ..... 29
  - Lens hood ..... 28
  - Level gauge function ..... 49
  - Loop recording ..... 66
  - Low angle shooting ..... 71
- M**
- Macro ..... 46
  - [MAINTENANCE] ..... 147
  - Manual focus ..... 46
  - Matrix function ..... 55
  - Menu
    - Main menu ..... 123
    - [OPTION MENU] ..... 123
    - Setting menu ..... 124
    - [USER MENU] ..... 123
  - Metadata ..... 114
  - microP2 memory card ..... 33
    - Inserting ..... 33
    - Removing ..... 34
    - Write protect ..... 34
  - Microphone ..... 30
  - Mirror shooting ..... 39
  - Mode check ..... 157
  - Monitor ..... 160
- N**
- ND filter ..... 46
  - Network ..... 174
    - Settings ..... 177
    - Wired LAN ..... 176
    - Wireless LAN ..... 175
  - [NETWORK SETUP] ..... 142
- O**
- One-clip recording ..... 67
  - One-shot recording ..... 66
  - [OTHER FUNCTIONS] ..... 147
  - [OUTPUT SEL] ..... 141

## Index

<b>P</b>	
P2 card .....	33
Formatting .....	116
Recording time .....	35
Status .....	34
Status display .....	118
P2 memory card .....	33
Inserting .....	33
Removing .....	34
Write protect .....	34
Pre-recording .....	65
Properties .....	117
Proxy recording .....	83
<b>R</b>	
RB gain control function .....	55
Rec during upload function .....	189
Recording check function .....	70
Recording format .....	81
Recording functions .....	65
[RECORDING SETUP] .....	136
Remote control .....	160, 170
<b>S</b>	
Safety zone marker .....	71
Scan reverse shooting .....	71
[SCENE FILE] .....	127
Scene file data .....	91
SD memory card .....	18
Formatting .....	90, 116
Handling .....	89
Inserting .....	90
Operation .....	90
Removing .....	90
Status display .....	120
Setting data .....	89
Setting menu .....	124
Basic operations .....	124
Initializing .....	93, 125
Setting [USER MENU] .....	125
Shooting .....	43
Shot mark .....	70, 111
Shot mark recording .....	70
Shoulder strap .....	28
Shutter mode .....	58
Shutter speed .....	58
Simultaneous recording .....	68
Skin tone function .....	54
Specifications .....	202
Storage device	
Exporting .....	165
Formatting .....	164
Information display .....	166
Streaming function .....	87
Super gain .....	46
[SW MODE] .....	134
[SYSTEM MODE] .....	132
<b>T</b>	
Tally lamp .....	41
Text memo .....	111
Text memo recording .....	70
Thumbnail .....	107
Changing .....	111
Selecting .....	109
Setting .....	109
Time code .....	101
Time data .....	95
Time stamp function .....	72
Time zone .....	32
Tripod .....	30
TV .....	160
<b>U</b>	
USB .....	162
Device mode .....	162
Host mode .....	162
User bits .....	99
USER button .....	37
User data .....	91
[USER MENU SEL] .....	148
[USER SW] .....	133
<b>V</b>	
Variable frame rate .....	60
Viewfinder .....	40
Displaying screen .....	151
Status display .....	151
<b>W</b>	
Warning system .....	195
Waveform monitor function .....	73
White balance .....	50
White clip function .....	57
<b>Z</b>	
Zebra patterns .....	71
Zoom .....	53
Zoom ring .....	53

## Information for Users on Collection and Disposal of Old Equipment and used Batteries



These symbols on the products, packaging, and/or accompanying documents mean that used electrical and electronic products and batteries should not be mixed with general household waste. For proper treatment, recovery and recycling of old products and used batteries, please take them to applicable collection points, in accordance with your national legislation.



EU

By disposing of these products and batteries correctly, you will help to save valuable resources and prevent any potential negative effects on human health and the environment which could otherwise arise from inappropriate waste handling.



For more information about collection and recycling of old products and batteries, please contact your local municipality, your waste disposal service or the point of sale where you purchased the items.

Penalties may be applicable for incorrect disposal of this waste, in accordance with national legislation.

EU

### For business users in the European Union

If you wish to discard electrical and electronic equipment, please contact your dealer or supplier for further information.



Cd

### Information on Disposal in other Countries outside the European Union

These symbols are only valid in the European Union. If you wish to discard these items, please contact your local authorities or dealer and ask for the correct method of disposal.

### Note for the battery symbol (bottom two symbol examples):

This symbol might be used in combination with a chemical symbol. In this case it complies with the requirement set by the Directive for the chemical involved.