

# EOS 5D Mark II

## Pocket Guide

This quick guide explains basic function settings and how to shoot and playback images. You can take this guide with you for shooting. For detailed instructions, refer to the EOS 5D Mark II Instruction Manual.



English Edition  
© CANON INC. 2008

### Quick Start Guide

- Insert the battery.
- Attach the lens. Align the red dot.
- Set the lens focus mode switch to <AF>.
- Open the cover and insert a CF card.
- Set the power switch to <ON>.

- Set the Mode Dial to **<Full Auto>**. All the necessary camera settings will be set automatically.
- Focus the subject. Aim the AF point over the subject and press the shutter button halfway to autofocus.
- Take the picture. Press the shutter button completely to take the picture.
- View the image. The captured image will be displayed for about 2 sec. on the LCD monitor.
  - The **☆** on the right of the function indicates that the function is available only when the Mode Dial is set to **P, Tv, Av, M, or B**.
  - Battery Life**

Temperature	At 23°C / 73°F	At 0°C / 32°F
Possible shots	Approx. 850 shots	Approx. 750 shots

### Image Playback

Index Magnify

### Preparation

#### Menu Operations

- Press the **<MENU>** button to display the menu.
- Turn the **<Main Dial>** to select the tab, then turn the **<Quick Control Dial>** to select the desired item.
- Press **<SET>** to display the setting.
- After setting the item, press **<SET>**.

#### Fully-Automatic Modes (P/Tv/Av/M/B Modes)

**P/Tv/Av/M/B Modes**

Menu items    Menu settings

### Menu Settings

#### Shooting 1

- Quality
- Beep On
- Shoot w/o card On
- Review time 2 sec.
- Peripheral illumin. correct.

#### Shooting 2

- Expo.comp./AEB -2..1..0..1..2
- White balance AWB
- Custom WB 0.0/±0
- Color space sRGB
- Picture Style Standard
- Dust Delete Data

#### Playback 1

- Protect images
- Rotate
- Erase images
- Print order
- Transfer order

#### Playback 2

- Highlight alert Disable
- AF point disp. Disable
- Histogram Brightness
- Slide show
- Image jump w/ 10 images

#### Set-up 1

- Auto power off 1 min.
- Auto rotate On
- Format
- File numbering Continuous
- Select folder

#### Set-up 2

- LCD brightness Auto
- Date/Time 09/17/08 13:10
- Language English
- Video system NTSC
- Sensor cleaning
- Live View/Movie func. set.

#### Set-up 3

- Battery info.
- INFO. button Normal disp.
- External Speedlite control
- Camera user setting
- Clear settings
- Firmware Ver. 1.0.0

#### Custom Functions

- C.Fn I :Exposure
- C.Fn II :Image
- C.Fn III :Autofocus/Drive
- C.Fn IV :Operation/Others
- Clear all Custom Func. (C.Fn)

#### Picture Style

- Standard
- Portrait
- Landscape
- Monochrome

All these screens show the options displayed in the **P/Tv/Av/M/B** modes. In the fully-automatic modes (P/CA), the [INFO/★] tab and [▶] are not displayed.

### Quick Control Screen

Press **<Quick Control Dial>** straight down. The Quick Control screen will appear.

- Tilt the **<Quick Control Dial>** to select the function, then turn the **<Main Dial>** or **<Quick Control Dial>** to set it.
- In the fully-automatic modes (P/CA), you can select certain drive modes and the image-recording quality.

### Image-recording Quality

- Select **[Quality]**.
- Turn the **<Main Dial>** or **<Quick Control Dial>** to select the quality and press **<SET>**.

#### Image-recording quality

Quality

RAW: Turn the **<Main Dial>** to select the quality.

JPEG: Turn the **<Quick Control Dial>** to select the quality.

#### Picture Style

- Press the **<Picture Style>** button.
- Turn the **<Main Dial>** or **<Quick Control Dial>** to select the Picture Style.

Style	Description
<b>Standard</b>	Vivid colors and sharp images.
<b>Portrait</b>	Nice skin tones and slightly sharp images.
<b>Landscape</b>	Vivid blue skies and greenery and very sharp images.
<b>Monochrome</b>	Black-and-white images.

- For **<Neutral>** and **<Faithful>**, see the camera's instruction manual.

# Shooting Operation

## Nomenclature

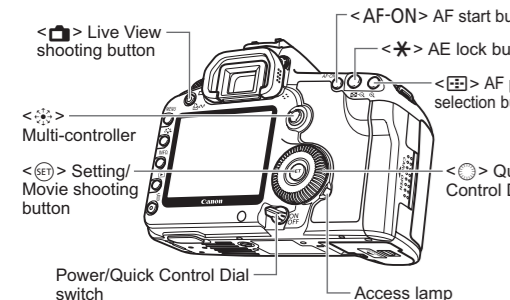
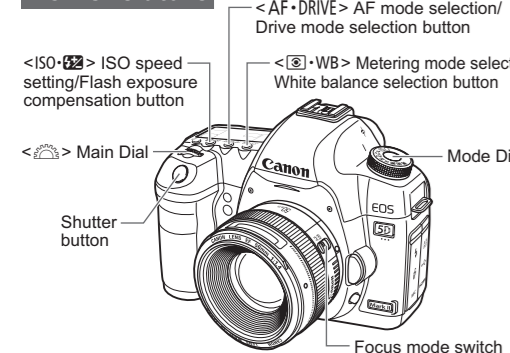

## LCD Panel

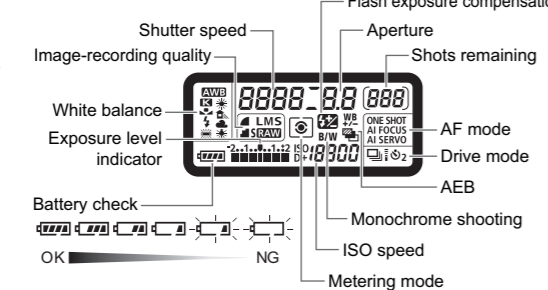

## Viewfinder Information

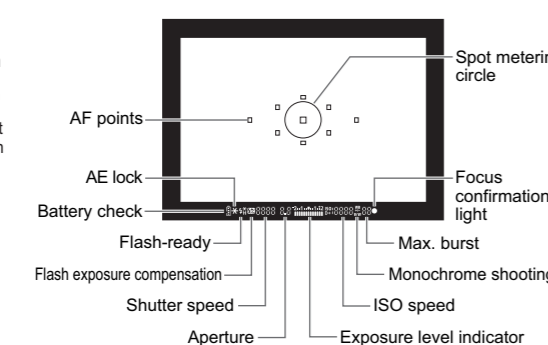

## Fully-Automatic Modes (□/CA)

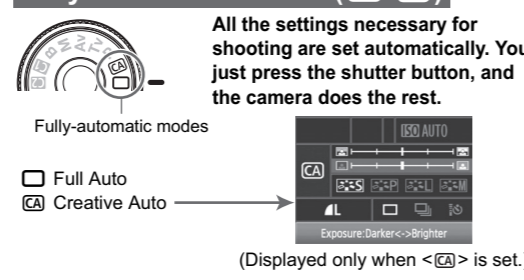

- Press  $\downarrow$  straight down, then tilt  $\rightarrow$  to select the function.
- Turn the  $\rightarrow$  or  $\leftarrow$  dial to set the function.

## P/Tv/Av/M Modes

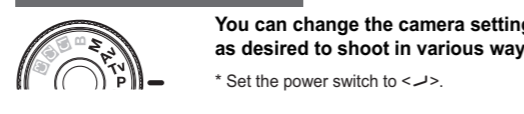

- Set the Mode Dial to **P**.
- As with the  $\square$  mode, when focus is achieved, the shutter speed and aperture will be automatically set.

## Tv: Shutter-priority AE

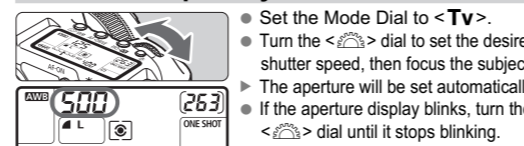

## Av: Aperture-priority AE

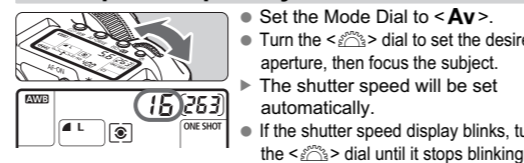

## M: Manual Exposure

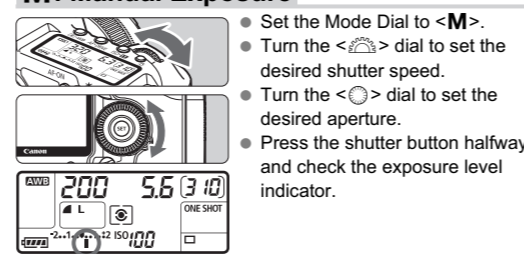

## AF: AF Mode $\star$

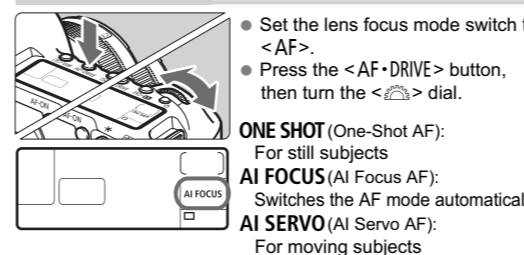

## AF Point $\star$

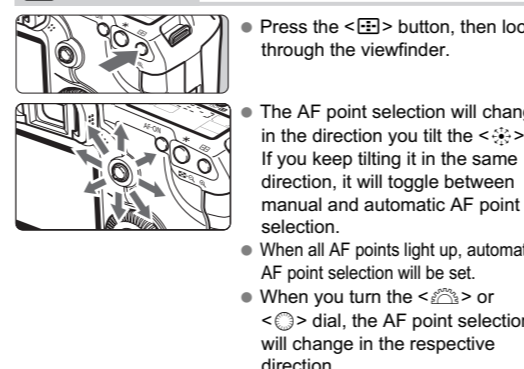

## ISO: ISO Speed $\star$

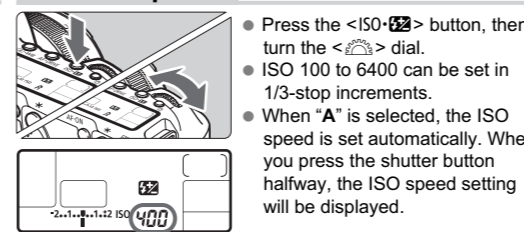

## Drive Mode $\star$

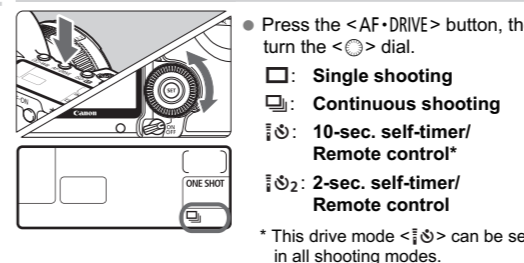

## Live View Shooting

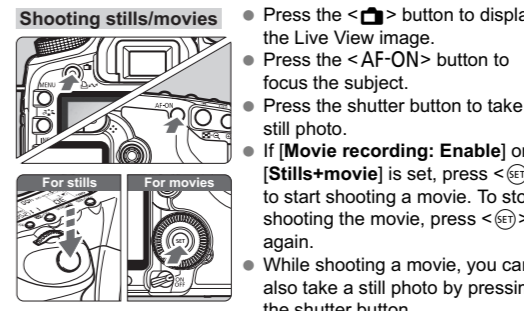
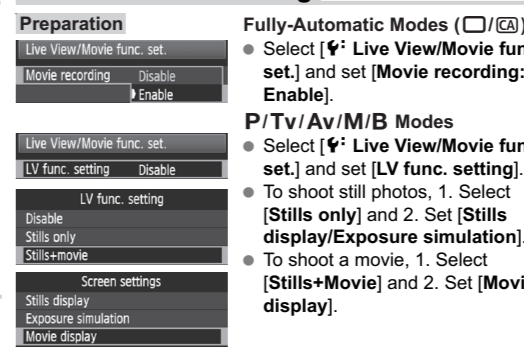

# Custom Functions

## C.Fn I: Exposure

1	Exposure level increments	2	Lens AF stop button function
2	ISO speed setting increments	3	AF point selection method
3	ISO expansion	4	Superimposed display
4	Bracketing auto cancel	5	AF-assist beam firing
5	Bracketing sequence	6	Mirror lockup
6	Safety shift	7	AF point area expansion
7	Flash sync. speed in Av mode	8	AF Microadjustment

## C.Fn II: Image

1	Long exposure noise reduction	2	AF-ON/AE lock button switch
2	High ISO speed noise reduction	3	Assign SET button
3	Highlight tone priority	4	Dial direction during Tv/Av
4	Auto Lighting Optimizer	5	Focusing screen

## C.Fn III: Autofocus/Drive

1	Lens drive when AF impossible
---	-------------------------------

## C.Fn IV: Operation/Others

1	Shutter button/AF-ON button
2	AF-ON/AE lock button switch
3	Assign SET button
4	Dial direction during Tv/Av
5	Focusing screen
6	Add original decision data